

Measurement and Monitoring in Anaesthesia

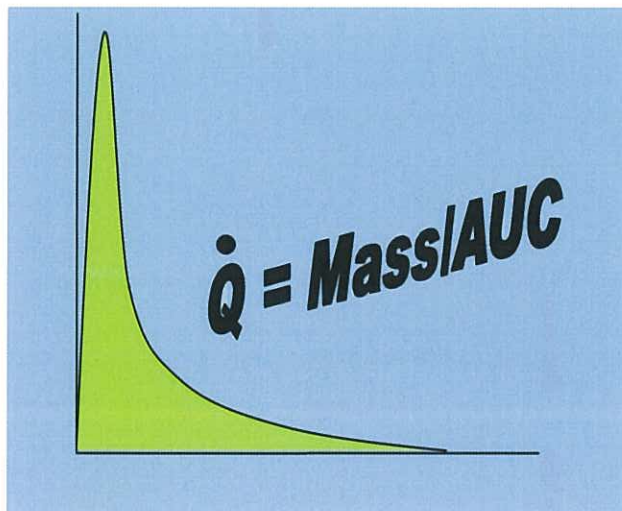

"All science is either physics or stamp collecting."

Ernest Rutherford

Alan McLintic
Department of Anaesthesia
Middlemore Hospital

INTRODUCTION

The notes in this book have been compiled over a 20 yr period teaching measurement and monitoring for Part 1 FANZCA candidates in Middlemore Hospital. They are continuously corrected, reworded, refined and updated to keep up with improved technology and exam requirements. I have never intended them to be used outside Middlemore tutorials or to be sold on in any capacity or to be distributed more widely. Thus, I can keep the text relatively loose and minimise references. For these reasons I do not give permission for the book to be reproduced in print, PDF or other electronic form or distributed by a third party without my permission. I hope you find the text useful but, in exchange, I would ask you please to respect the above considerations.

Alan McLintic
Middlemore Hospital

Contents

INTRODUCTION	2
CONTENTS	3
PHYSICS OF PRESSURE MEASUREMENT.....	8
FORCE	8
<i>Gravitational units</i>	8
PRESSURE.....	8
GAUGE AND ABSOLUTE PRESSURE.....	9
SURFACE TENSION.....	9
PRESSURE GAUGES	11
1. <i>Liquid manometers</i>	11
2. <i>Anaeroid gauges</i>	12
3. <i>Diaphragm / strain gauges</i>	12
WHEATSTONE BRIDGE.....	13
NON-INVASIVE BLOOD PRESSURE MEASUREMENT.....	14
RIVA - ROCCI CUFF + MERCURY MANOMETER / ANAEROID GAUGE	14
VON RECKLINGHAUSEN OSCILLOTONOMETER.....	16
OSCILLOMETRIC CUFF SYSTEMS (EG 'DINAMAP').....	16
PENAZ TECHNIQUE EG 'PORTAPRES' OR 'FINAPRES'.....	18
ARTERIAL TONOMETRY.....	18
INVASIVE ARTERIAL PRESSURE MONITORING.....	19
INFORMATION FROM ARTERIAL PRESSURE TRACE.....	19
COMPLICATIONS.....	19
DEFINITIONS.....	20
STATIC ACCURACY	20
DYNAMIC ACCURACY.....	21
CHECKING DAMPING AND ESTIMATING THE DAMPING COEFFICIENT	24
PRACTICAL CONSIDERATIONS IN ACCURACY	26
CENTRAL VENOUS PRESSURE	27
APPLICATIONS.....	27
INFORMATION FROM CVP LINE.....	27
PATHOLOGY.....	27
COMPLICATIONS.....	28
PRACTICAL POINTS	28
PULMONARY ARTERY CATHETERISATION.....	29
BASIC PRINCIPLES.....	29
NORMAL PRESSURE TRACE AND VALUES.....	29
PAOP AS AN INDICATOR OF LV FILLING	30
<i>Why is CVP an unreliable indicator of LV filling?</i>	30
SOME CLINICAL APPLICATIONS OF THE PULMONARY ARTERY CATHETER.....	31
COMPLICATIONS.....	32
INACCURACIES	32
MONITORING MIXED VENOUS OXYGEN SATURATION.....	34
CARDIAC OUTPUT.....	35
ULTRASOUND.....	35
DILUTION TECHNIQUES.....	37
<i>Fick principle</i>	37
<i>Dye dilution and Thermodilution</i>	37
PULSE CONTOUR AND PULSE PUMP ANALYSIS	41
<i>General points</i>	41
<i>'Pulsion' Pulse Contour Cardiac Output (PiCCO)</i>	41
<i>LiDCOplus</i>	42

<i>Uncalibrated invasive pulse analysis</i>	42
<i>Uncalibrated non-invasive pulse analysis (Volume clamp method)</i>	43
OTHER METHODS.....	43
<i>Thoracic bioimpedence</i>	43
<i>NICO</i>	44
<i>Radionuclide</i>	44
<i>MRI</i>	44
DERIVED HAEMODYNAMIC AND METABOLIC PARAMETERS	45
ULTRASOUND	46
PHYSICAL PRINCIPLES	46
THE ULTRASOUND IMAGE	47
IMAGE MODES	50
DOPPLER	51
<i>Measurement of cardiac output using Doppler</i>	52
<i>Measurement of cardiac output using 2D-Echocardiography</i>	53
THE ELECTROCARDIOGRAM.....	54
12 LEAD ECG	54
3 ELECTRODE SYSTEM	55
5 LEAD SYSTEM	56
MODIFIED BIPOLAR STANDARD LEADS	56
FEATURES OF THE ELECTROCARDIOGRAM	56
ARTEFACT	63
COMMON-MODE REJECTION	63
FILTERING MODES	64
PULSE OXIMETRY.....	65
TERMINOLOGY	65
PHYSICAL PRINCIPLES OF LIGHT ABSORPTION.....	65
KEY PRINCIPLES OF PULSE OXIMETRY	65
PROBLEMS / INACCURACIES.....	68
MEASUREMENT OF EXPIRED CO₂.....	69
INFRA-RED ABSORPTION SPECTROPHOTOMETRY	69
PH CHEMICAL COLOURIMETRY	72
HALDANE APPARATUS	72
OTHERS	72
OXYGEN ANALYSIS	73
OXYGEN TENSION.....	73
<i>Paramagnetic (Pauling) analyser</i>	73
<i>Electrochemical cells – general notes</i>	75
<i>Fuel cell</i>	75
<i>Oxygen electrode</i>	76
<i>Ultrasonic</i>	77
<i>Fluorescence</i>	77
<i>Others:</i>	77
OXYGEN CONTENT	78
<i>Calculation from saturation</i>	78
<i>Van Slyke apparatus</i>	78
<i>Lex O₂ Con</i>	78
ANAESTHETIC VAPOUR ANALYSIS.....	79
INFRARED AGENT ANALYSERS	79
ULTRAVIOLET	80
PHOTOACOUSTIC SPECTROMETRY	80
RAMAN SCATTERING	80
LASER ANALYSERS	81
MASS SPECTROMETRY	81
PIEZOELECTRIC CRYSTAL RESONANCE	82

THERMAL CONDUCTIVITY/ KATHAROMETERS	83
EMISSION OF ELECTROMAGNETIC RADIATION (GAS DISCHARGE TUBE).....	83
SOLUBILITY	83
DENSITY (WALLER CHLOROFORM BALANCE).....	83
ULTRASOUND	83
INTERFEROMETER / REFRACTOMETER	83
GAS-LIQUID CHROMATOGRAPHY	85
LABORATORY MEASUREMENT OF PH AND CO₂.....	86
MEASUREMENT OF PH.....	86
PH ELECTRODE	86
ION SENSITIVE FIELD EFFECT TRANSISTOR.....	88
MEASUREMENT OF PCO ₂	88
ALPHA STAT AND PH STAT.....	92
HEAT AND TEMPERATURE	93
HEAT	93
TEMPERATURE	93
SPECIFIC HEAT CAPACITY	93
HEAT CAPACITY	93
LATENT HEAT	94
SPECIFIC LATENT HEAT.....	94
EXAMPLES OF RELEVANCE TO ANAESTHESIA.....	95
ADIABATIC PROCESS	96
TEMPERATURE	97
TEMPERATURE	97
MEASUREMENT OF TEMPERATURE	97
<i>Non-electrical / Direct reading</i>	97
<i>Electrical/ Remote reading</i>	98
WHAT IS A VAPOUR?	101
HUMIDITY.....	102
PHYSICAL PRINCIPLES	102
MEASURING HUMIDITY.....	103
METHODS OF HUMIDIFICATION.....	104
VAPORISERS	108
CLASSIFICATION.....	108
FUNCTION OF A TYPICAL PLENUM VARIABLE BYPASS VAPORISER	108
DUAL-CIRCUIT GAS-VAPOUR BLENDER.....	110
THE ALADIN CASSETTE (ADU MACHINE, DATEX OHMEDA).....	111
DRAGER DIVA (AS FOUND ON DRAGER ZEUS ANAESTHETIC MACHINE).....	111
RESPIRATORY MEASUREMENT	112
WORK AND POWER.....	114
<i>The pressure-volume diagram</i>	114
<i>The Campbell diagram</i>	116
<i>Pressure - volume loop in lung disease</i>	117
MEASUREMENT OF LUNG VOLUMES – EXCLUDING RESIDUAL VOLUME.....	119
MEASUREMENT OF LUNG VOLUMES – INCLUDING RESIDUAL VOLUME	120
1. <i>Measurement of FRC using the body plethysmograph</i>	120
2. <i>Helium dilution</i>	122
3. <i>Nitrogen dilution / washout</i>	122
ANATOMICAL DEAD SPACE.....	124
CLOSING VOLUME AND CLOSING CAPACITY	124
MEASUREMENT OF AIRWAYS RESISTANCE.....	125
LUNG COMPLIANCE	128
MEASUREMENT OF DIFFUSING CAPACITY / TRANSFER FACTOR	129
FLOW STUDIES.....	133

MEASUREMENT OF GAS FLOWS	138
HOT WIRE ANEMOMETER	138
PNEUMOTACHOGRAPH	138
PITOT TUBE	139
VARIABLE ORIFICE FLOWMETER (ROTAMETER)	140
WRIGHT'S ELECTRONIC SPIROMETER	141
WRIGHT PEAK FLOWMETER.....	141
FLOW MEASUREMENT IN MODERN ANAESTHETIC MACHINES	141
FLUID FLOW	143
FLUIDS	143
LAMINAR FLOW	143
VISCOSITY.....	144
TURBULENT FLOW.....	145
<i>Prediction of onset of turbulent flow – Reynold's number</i>	146
<i>Clinical aspects</i>	147
BERNOULLI PRINCIPLE.....	148
COANDA EFFECT.....	148
GAS LAWS	150
ATOMIC STRUCTURE.....	150
THE GAS LAWS	152
BOYLES'S LAW	152
CHARLES'S LAW	152
THIRD PERFECT GAS LAW (GAY-LUSSAC'S LAW)	153
DALTON'S LAW OF PARTIAL PRESSURES	153
AVOGADRO'S HYPOTHESIS	153
IDEAL GAS LAW	154
CRITICAL TEMPERATURE.....	155
CRITICAL PRESSURE	155
HENRY'S LAW	155
ISOTHERMS:.....	156
PSEUDOCRITICAL TEMPERATURE.....	157
SOLUBILITY	158
CEREBRAL MONITORING.....	159
ELECTROENCEPHALOGRAPH.....	159
PHYSIOLOGICAL VARIATIONS ON THE EEG	159
EEG IN PATHOLOGICAL STATES	161
THE EEG IN ANAESTHESIA	162
BISPECTRAL INDEX.....	163
<i>Ability of BIS to reduce awareness – summary of research to date</i>	164
ENTROPY	164
NARCOTREND INDEX	165
AUDITORY EVOKED POTENTIALS (AEP's).....	165
COMPRESSED SPECTRAL ARRAY	168
OTHER NEUROANAESTHESIA MONITORS	170
CEREBRAL FUNCTION MONITOR (CFM).....	170
SOMATOSENSORY EVOKED POTENTIALS (SSEP'S).....	170
VISUAL EVOKED RESPONSES.....	171
MOTOR EVOKED POTENTIALS	172
INTRACRANIAL PRESSURE MONITORING.....	173
INTRACRANIAL PRESSURE MONITORS	173
NOTES ON PRACTICAL ISSUES	173
ICP WAVEFORMS DURING RAISED INTRACRANIAL PRESSURE	174
MEASUREMENT OF CEREBRAL BLOOD FLOW	175
<i>Techniques</i>	175
<i>Kety-Schmidt</i>	175

THE EXPONENTIAL PROCESS	177
OTHER CURVES:	179
ELECTRICAL PRINCIPLES.....	181
GENERAL PRINCIPLES AND DEFINITIONS	181
<i>Charge and current</i>	181
<i>Voltage</i>	183
<i>Resistance</i>	183
<i>Power</i>	185
ELECTROMAGNETIC PRINCIPLES.....	185
CAPACITANCE	188
GALVANOMETERS, AMMETERS AND VOLTMETERS.....	189
THE DEFIBRILLATOR	191
DEFIBRILLATOR CIRCUIT.....	191
MONOPHASIC V BIPHASIC DEFIBRILLATORS	193
<i>Monophasic defibrillators</i>	193
<i>Biphasic defibrillators</i>	193
ELECTRICAL SAFETY	194
MACROSHOCK.....	194
<i>Risk to patient</i>	194
PROTECTION AGAINST MACROSHOCK – SUMMARY.....	194
<i>Patient issues</i>	195
<i>Equipment issues</i>	195
MICROSHOCK	197
ELECTRICAL SAFETY SYMBOLS.....	198
ELECTROSURGERY	200
<i>The Harmonic scalpel</i>	201
L.A.S.E.R.....	202
<i>Lasers and theatre safety</i>	203
ASSESSMENT NEUROMUSCULAR BLOCKADE.....	205
CLINICAL ASSESSMENT.....	205
PERIPHERAL NERVE STIMULATORS	205
<i>Assessing the response</i>	205
<i>Stimulation Patterns</i>	205
<i>Problems and Safety aspects</i>	207
SCAVENGING	208

PHYSICS OF PRESSURE MEASUREMENT

Force

Definition	That which changes the state of rest or motion of an object. If there is no force acting on an object it is either stationary or moving at constant velocity
Express force in terms of mass	Force = Mass x acceleration The more force, the more is the acceleration.
S.I units	newton (N)
1 newton =	Force required to give a 1 kg mass an acceleration of 1ms^{-2}
=	1 kg m s^{-2}
1 dyne =	Force required to give 1 gram an acceleration of 1 cms^{-2}
=	= 1 / 100,000 the force of 1 newton

Gravitational units

Force of gravity on 1 kg	$9.81\text{ kg ms}^{-2} = 9.81\text{ N}$
What is this force called?	1 kg weight
1 newton	102 g weight

Pressure

Definition	Force applied per unit area
Relate pressure and force	Pressure (P) = Force (f) / surface area (a)
S.I units	pascal (Pa) = $1\text{N} / \text{m}^2$
More commonly used units	kilopascal (kPa)
1 atmosphere =	101.325 kPa

Conversion factor for 100 kPa	
cmH ₂ O	1020
bar	1
mmHg	~750
Torr	~750
lb/in ²	14.5
dyne. cm ⁻²	10 ⁶

Gauge and absolute pressure

Definition gauge pressure	Pressure above or below atmospheric pressure
Definition absolute pressure	Gauge pressure + atmospheric pressure
Gauge pressure full cylinder of oxygen	137 bar
Absolute pressure full cylinder O ₂	138 bar

Surface tension

Why do some substances 'wet' surfaces (eg water) and others don't (eg mercury)?

There are mutual attractive forces between the molecules of a substance (*cohesion*). If these are greater than their attraction to another substance (*adhesion*) they will not wet the surface.

What is surface tension?

The molecules at the surface of a liquid have no neighbouring molecules above, so the cohesive forces between their surface neighbours are enhanced. The force of attraction between molecules on the surface is called surface tension and causes the liquid surface area to be as small as possible.

How is surface tension expressed?

Forces between molecules on either side of an imaginary line. *The force required to break the skin over a certain distance.*

Flat surface

Tension (newtons m⁻¹) = Force / Unit length

Surface tension in bubbles

The forces of surface tension in a bubble act on the inner and outer surfaces as if to keep imaginary halves of the bisected sphere together.

Why is a bubble a sphere?

Surface tension causes the surface to contract to the smallest surface area per unit volume. This results in an increase in internal pressure until an equilibrium is reached.

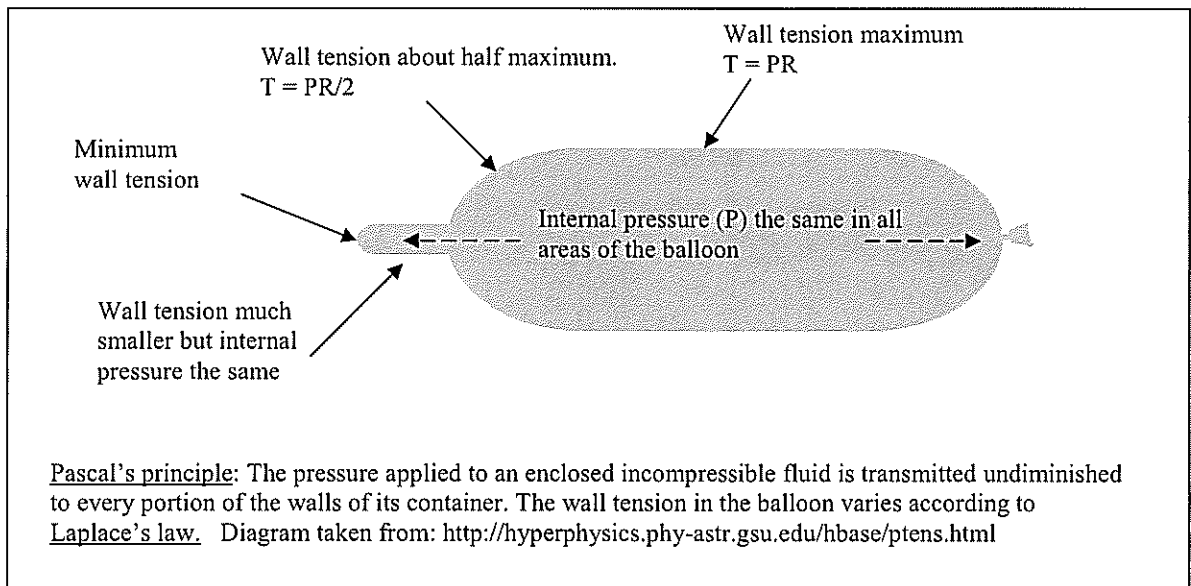

Laplace's Law:

Relates transmural pressure, radius and surface tension in a distensible vessel

2 radii

$$P = T/r_1 + T/r_2 \text{ (} r_1 \text{ and } r_2 \text{ radii in two direction)}$$

Cylinder/ artery

$$P = T / r$$

Bubble (2 surfaces)

$$P = 4T / r$$

Sphere or alveolus (1 surface)

$$P = 2T / r$$

Clinical relevance Laplace implies that, as alveoli reduce in size, the increase in internal pressure might cause the alveolus to empty and collapse. Surfactant reduces surface tension so much that, as the radius decreases, the internal pressure actually drops and the alveoli stabilise at about a quarter of normal.

Laplace's law: The larger the radius, the larger the wall tension required to withstand the internal pressure. Diagram taken from: <http://hyperphysics.phy-astr.gsu.edu/hbase/ptens.html>

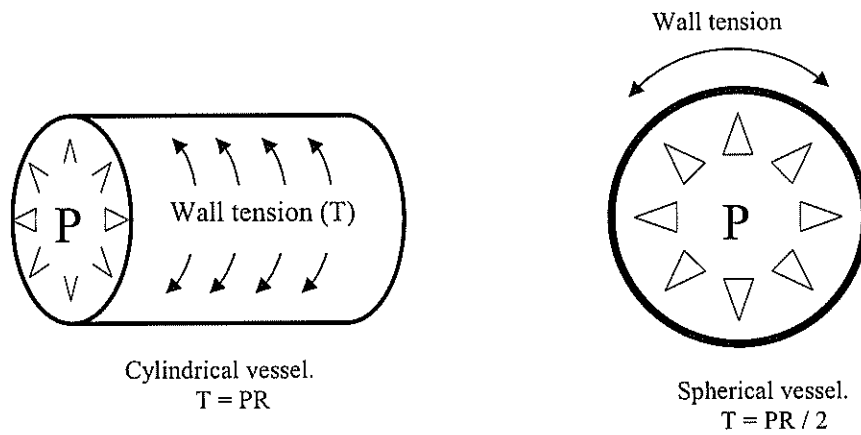

Laplace's law: Why wall tension increases with radius. Diagram taken from: <http://hyperphysics.phy-astr.gsu.edu/hbase/ptens.html>

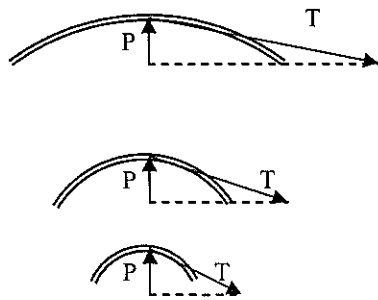

The wall tension opposing the internal pressure is applied more indirectly as radius increases. This means that the required tension must be greater to balance the internal pressure. The length of line T represents magnitude of surface tension

Cable analogy: Imagine the change in required cable tension if you were to support the weight as in (b)

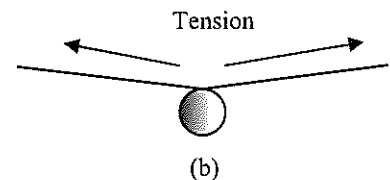

Pressure gauges

Classification of pressure gauges

- i) Liquid manometer
- ii) Anaeroid gauges - Bourdon, bellows
- iii) Diaphragm + direct movement of lever (strain gauges)
 - electromechanical transducer
 - optical
 - wire strain
 - silicon strain
 - capacitor
 - inductance

1. Liquid manometers

Pressure exerted by a column of liquid depends on what?

Force of gravity on mass of liquid in column

Is the area of the column important in a water manometer?

No. Although the mass and, therefore, the total force exerted by the column increases with an increase in the column area, as pressure is the effect of the force distributed over the same larger area, the pressure stays the same.

Relevance of cohesive and adhesive forces in measurement

i) In a water manometer the adhesive forces of water to glass are stronger than the cohesive forces. Water tends to spread outwards to the glass surface and is drawn up the tube causing a concave (upwards) *meniscus*. In a mercury manometer the cohesive forces are stronger than the adhesive forces causing a convex (upwards) meniscus.

Where do you read level ?

Centre of tube.

How *might* this affect manometer readings?

ii) If a tube is dipped in a reservoir of water, water tends to be drawn up the tube until the force of gravity on the mass of water above the reservoir level overcomes the adhesive force. This is termed *capillarity*. Water rises to a height that is inversely related to the radius of the tube. With mercury the column of liquid would fall below the reservoir height.

Water manometer -over-reads (4.5 mm too high in 6 mm tube)
Mercury manometer -under-reads (1.5 mm too low in 6 mm)

How many more times dense is mercury compared with water ?

13.6

How much greater is the force exerted by its weight compared with water ?

13.6 times

In tubes of the same diameter, how much mercury would support 10.2 cm water?

7.5 mm Hg

Example of a mercury manometer

Sphygmomanometer

Should the end of the manometer in a sphygmomanometer be open or closed?

Open because you're measuring gauge pressure

When is the end of a mercury manometer sealed?

Barometer (torricellian vacuum is present above the mercury) and thermometer

2. Anaeroid gauges

Definition anaeroid	without liquid
Example	Bourdon gauge (cylinder pressure) Bellows / capsule anaeroid (mechanical ventilators, VR oscillotonometer)
How does a Bourdon gauge work?	High pressure causes a tube (one end connected to the pressure source and the other end sealed) to uncoil, moving a pointer

3. Diaphragm / strain gauges

Basis	Pressure changes causes movement of a flexible diaphragm
How is movement of diaphragm sensed?	i) Wire strain gauge - stretched or compressed wire undergoes a change in resistance which is detected by a Wheatstone bridge. ii) Silicon strain gauge-as for wire strain gauge but more sensitive. iii) Optical - reflection of light off bulging diaphragm changes amount detected at photoelectric cell (some fibre optic cardiac catheters) iv) Capacitance - diaphragm is one plate of a capacitor. Distance from other plate varies with movement of diaphragm. v) Inductance - diaphragm attached to a magnet which is moved between coils as the diaphragm bulges → potential induced
Other classification of pressure transducers	Single-ended - (most) Measure pressure on one side only. Differential - Pressure difference is measured across a diaphragm or resistance as in pneumotachograph.

SOME USEFUL PRESSURES TO REMEMBER

Pipeline pressure	420 kPa
O2 cylinder pressure	13700 kPa
N2O cylinder	4400 kPa
CO2 cylinder	4980 kPa
1° pressure regulators	→ 420 kPa
Machine 'working' pressure	420 kPa
Back bar pressure relief valve blows at:	30 – 42 kPa
Auxiliary gas outlet pressure	300 – 400 kPa
Beginning back bar (no vapour)	
Beginning back bar (no vaporisers) 5 l/min	~ 12 cmH2O

Wheatstone bridge

What is it?

A method of measuring electrical resistance.

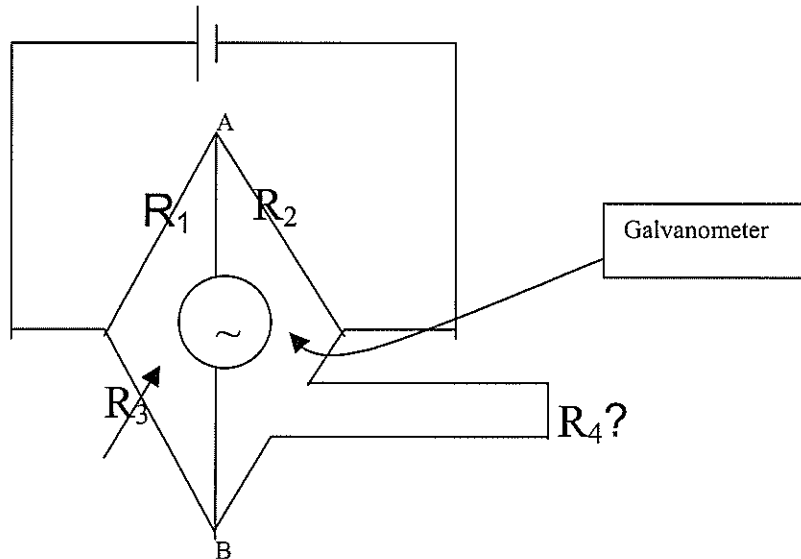

R1 and R2 are known resistances. R3 is a variable resistor. R4 is the unknown resistance. R3 is adjusted until the resistances on each limb of the circuit are balanced and there is no potential across the circuit between points A and B. When this occurs the galvanometer reads zero and the ratio of resistances in the known leg equals that in the unknown leg. Thus, R4 is found by solving: $R_1 / R_2 = R_3 / R_4$

Resistance is very temperature dependant so R1 and R2 are, where possible, kept at the temperature of the measured entity.

See chapter on Electrical principles for further detail.

Why is it the *ratio* of resistances that is important?

Kirchhoff's rules

1. *The sum of the potential drops around a circuit must equal the sum of potential increases*

Thus, the potential difference across the galvanometer will be zero when the potential drop (E) across R₁ = that across R₃, ($I_1 * R_1 = I_3 * R_3$) and the potential drop across R₂ = that across R₄, ($I_2 * R_2 = I_4 * R_4$).

2. *At a junction in a circuit where the current can divide, the sum of the currents into the junction equals the sum of currents out of the junction.*

Thus $I_1 = I_2$ and $I_3 = I_4$

Thus:

$$R_4 = \frac{E_4}{I_4} = \frac{(I_2 * R_2)}{\left(\frac{(R_1 * I_1)}{R_3}\right)} = \frac{(R_2 * I_2)R_3}{(R_1 * I_2)} = \frac{(R_2 * R_3)}{R_1} \text{ and thus } \frac{R_1}{R_2} = \frac{R_3}{R_4}$$

NON-INVASIVE BLOOD PRESSURE MEASUREMENT

Manual

- 1) Riva - Rocci cuff + mercury manometer / anaeroid gauge +
 - a) Palpation
 - b) Plethysmography
 - c) Korotkoff method -stethoscope
- microphone
 - d) Doppler
- 2) Von Recklinghausen oscillotonometer

Automated

- 1) Automated oscillometric eg DINAMAP (Device for indirect non-invasive automatic mean arterial pressure)
- 2) Penaz technique (Finapres)
- 3) Arterial tonometry

Riva - Rocci cuff + mercury manometer / anaeroid gauge

Components	Single cuff Tubing + bulb Mercury manometer or anaeroid gauge (less accurate and requires regular recalibration) Detector -stethoscope, microphone, pleth., doppler
Cuff size	Width 40% circumference of arm Width should be 2/3 upper arm
Speed of deflation	2 - 3 mmHg per second
Manometer	Positioned vertically (unless calibrated for a tilt) Mercury / pointer must start at zero
Is height of patient important?	No. Tubing filled with air exerts no significant mass effect on transducer
Variations in methods of detection:	

Palpation

SBP by palpation lower than with Korotkoff
DBP unobtainable

Korotkoff sounds

I - sound appears - SBP
II - sounds become quieter
III - rise in volume
IV - muffling - (~ 8 mmHg higher than directly recorded DBP)
UK: DBP, USA: DBP in children
V - loss of sound - (~ 2 mmHg higher than direct DBP)
USA: DBP in adults

Problems with Kortocoff method:

Intrinsic accuracy	SBP slightly lower than direct measurement DBP generally over-estimated but not good correlation; much inter-observer error with both I and IV.
Technical	Leaks from or blockages in pneumatic system Cuff- misplacement wrong size - overreads if cuff too narrow underreads if too wide deflated too fast Manometer - air vent blocked, tilted Anaeroid gauge - needs regular recalibration
Patient characteristics	Hypotension - SBP overestimated AF and other arrhythmias - innaccurate Obesity - pressures overestimated Arteriosclerosis - sounds difficult to hear or overestimated Movement, shivering

Doppler

Doppler effect- Changes in observed frequency when source moves with respect to observer. The change in frequency is proportional to the velocity of the source with respect to the observer.

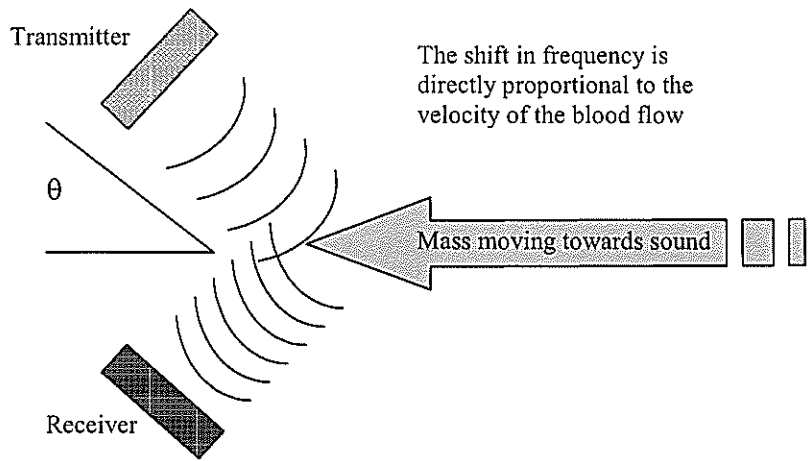

The Doppler effect

$$V = \frac{C.Fd}{2F_0 \cdot \cos \theta}$$

V = velocity
C = speed of sound through body tissues
Fd = frequency shift
F₀ = frequency of emitted sound
 θ = angle between emitted sound and moving object

i) Detection of blood flow
Cuff and manometer plus Doppler transducer placed distal to cuff. Cuff deflated :-
SBP - Change in frequency 'murmur-like' sound

	DBP - Change in character - more 'continuous' sound
ii) Detection of artery wall movement (eg Arteriosonde)	Cuff and manometer required as above. Transducer under cuff over artery. When cuff deflated and blood starts to flow, movement of the arterial wall results in a difference in frequency between transmitted and reflected sound and produces 'murmur-like' sound. Artery fully closed - no sound SBP- noise begins DBP -noise continuous (frequency shift is reduced)
Advantage -	Most accurate of non-invasive techniques particularly in neonates
Problems -	
Technical	Cuff, pneumatic, manometer problems (as above) Malpositioning of transducer Diathermy may cause artefact
Patient characteristics	Arrhythmias Patient movement

Von Recklinghausen Oscillotonometer

Basic operation	Two overlapping cuffs are connected by two tubes to two anaeroid bellows (one directly and one indirectly). The bellows are connected to a lever system, to which is attached a pointer. The systolic point is detected by sensing the onset of pulsations distal to the occluding cuff with the second, sensing cuff. SBP - needle swings make an abrupt increase in amplitude MAP – pressure at maximum oscillation DBP - sudden decrease in amplitude.
Intrinsic accuracy	SBP and MAP acceptable cf with direct measurement DBP useless
Technical problems	Very difficult to use ** Much inter-observer error (particularly with DBP) Cuff and pneumatic problems (as above)
Patient problems	Arrhythmias Obesity Movement Hypotension, peripheral vasoconstriction

Oscillometric cuff systems (eg 'Dinamap')

Basic operation	Single cuff occludes arterial flow and is then deflated. As cuff pressure falls below SBP, arterial pressure oscillations are transmitted via the cuff to the transducer in the module. <u>Note:</u> even when the cuff pressure is much higher or lower
-----------------	---

than BP there is still some interaction between blood and cuff so the amplitude never drops to zero, unlike the sounds of the stethoscope.

SBP
MAP
DBP

Sudden increase in magnitude of oscillations.
Lowest pressure at which maximum amplitude obtained
Abrupt diminution in amplitude.

Alternative measures

SBP

Pressure at point where pulsations are rising and are at 25 – 50% maximum

DBP

Pressure taken at point where pulse amplitude decreased by 80%

Note:

1. The method of determining SBP and DBP and MAP differ between machines so texts will differ in their explanations. For example, the MAP may be estimated from the sum of DBP and 1/3 pulse pressure.

2. Although only three stages of deflation are highlighted above, the oscillation profile is continuous and smooth. Very early devices could only measure MAP (hence DinaMAP). With time it became possible to correlate points on the waxing and waning amplitudes to SBP and DBP, although there is no sound theory as to their rationality. Subsequent versions took SBP and DBP as fractions of the maximum amplitude MAP. The designers based these on empirical calibration.

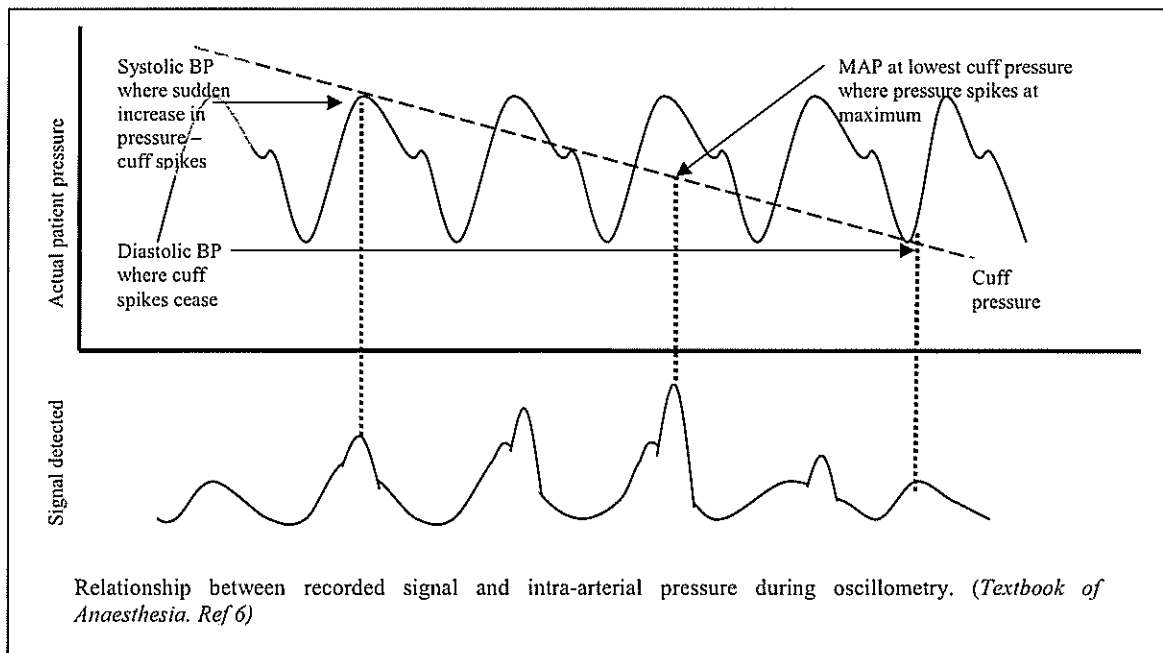

Problems:

Intrinsic accuracy

SBP reasonable correlation with invasive monitoring
MAP and DBP not as good (Although a 1979 study showed MAP to be the most reliable measure)

Technical

Intermittent -unable to follow rapid changes in pressure
Pneumatic and cuff problems as above

Patient

Patient movement
Obesity
AF

Hypotension - tends to overestimate SBP
 tends to underestimate DBP
 Hypertension tends to underestimate

Iatrogenic injury

Skin haematoma
 Nv. palsy

Penaz technique eg 'Portapres' or 'Finapres'

Basic operation

The pulsatile change in blood volume in the finger is matched by a counter force so that the finger artery is 'clamped' at a fixed diameter. The pressure required to do this is measured continuously. This is called the '*volume clamp principle*'
 - A photoplethysmograph is able to detect arterial blood volume (wavelength set at oxygenated blood) → rapid feed back to pneumatic cuff which inflates and deflates rapidly to 'clamp' the artery at a fixed volume
 - → the pressure in the cuff required to achieve this is continuously displayed.

Advantage

Virtual continuous BP measurement

Accuracy

Reasonable agreement with intra-arterial measurements even in shock. Underestimation of BP in hypertensive patients.

Disadvantage

Lactate build up → pain
 Venostasis
 Rarely, pressure sore under cuff

'Nexfin', 'Finometer'

Pulse contour analysis of non-invasive arterial trace to estimate cardiac output, SV variation and other parameters

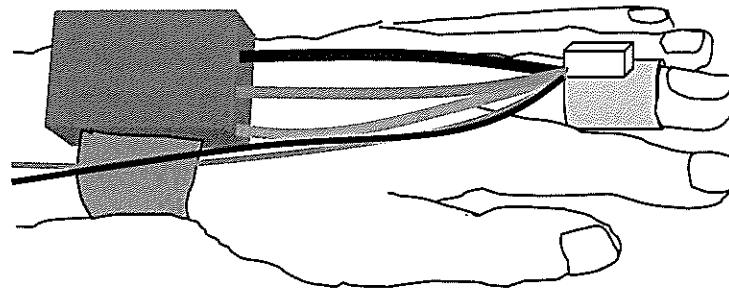

Arterial tonometry

Sensor applied over radial (usually) artery. Artery partly flattened against the radius. Pressure transduced waveform displayed
 Commercially available: Vasotrac™,; T-line Tensometer

INVASIVE ARTERIAL PRESSURE MONITORING

Information from arterial pressure trace

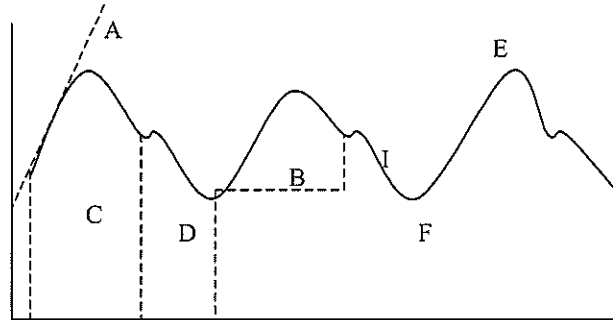

A	DP / DT	∞	contractility
B	AUC	∞	stroke volume
C	SBP x TIME	∞	myocardial O ₂ consumption
D	DBP x TIME	∞	myocardial O ₂ delivery
E	SBP		
F	DBP		
G	MAP (Area under curves C + D/time. This is termed the <i>geometric</i> mean and is less than the arithmetic MAP which is DBP + 1/3 PP)		
H	HR		
I	Diastolic decay ∝ resistance and compliance		

+ waveform

aortic valve disease, HOCM, pulsus paradoxus etc

Changes as you record further from aorta

Higher systolic pressure (distal systolic pulse amplification)
 Lower or normal EDP
 MAP radial reasonably close to that of aorta
 Wider pulse pressure
 ↑ delay pulse
 ↑ delay and slurring diastolic notch (termed 'incisura' when recorded at aorta)
 Prominent diastolic wave

Changes with increasing age

Higher SBP and ↑ pulse pressure
 ↑ pulse wave velocity from ↓ aortic peripheral compliance

Complications

- 1) Disconnection and haemorrhage
- 2) Flushing → embolisation (thrombo- or air embolism; ante- or retrograde)
- 3) Thrombosis and ischaemia
 - ↑ with duration, large cannula, shock, vascular disease
 - ? value of Allen's test
- 4) Infection

Definitions

Static accuracy	The accuracy of a system under static circumstances when compared with an absolute standard eg column of mercury
Dynamic accuracy	The accuracy of a system under dynamically varying pressure
Fundamental frequency	The slowest component frequency of a repetitive complex waveform.
Harmonics	Whole number multiples of the fundamental frequency. The latter is also termed the first harmonic. If the HR is 120 bpm the fundamental frequency is 2 Hz and the 2 nd and 3 rd harmonic are 4 Hz and 6 Hz respectively.
Fourier analysis	The division of a complex waveform into a fundamental frequency and a series of harmonics (with different frequencies, amplitudes and phases)
Natural frequency	The frequency at which a system oscillates when disturbed. Also termed the resonant frequency.
Damping	Tendency for a system to minimise these oscillations through viscous and frictional forces

Key Points: Accuracy in invasive pressure monitoring

Static accuracy	Base line stability (Zeroing) Calibration (Gain) Time stability Uniqueness		
Dynamic accuracy	Dynamic response	High natural frequency	Fn should be greater than frequency of biological signals, or resonance will occur High Fn required for optimum frequency response
		Optimal damping	Produces optimum frequency response Minimises phase distortion
	Others	Noise Physiological reactance	
Practical issues	Zero and calibrate Transducer placement Low compliance components Avoid bubbles, kinks, clots Choice of artery		

Static accuracy

Requirements	1. Must have stable zero baseline
--------------	-----------------------------------

2. Accurate reproduction of a fixed pressure
3. Linear gain.
4. Must be time-stable (Accuracy does not change with time)

Checking static accuracy

1. Check zero
 2. Check calibration with known pressure
 - internal calibration signal (eg 100 mmHg button on AS3 cable)
 - external calibration signal (eg column of mercury)
- Recheck zero and calibration after a period of time.

What is the importance of static accuracy in BP measurement?

Mean BP can usually be measured accurately even in a damped trace, because it is dependant on static accuracy alone.

Dynamic accuracy

What factors affect dynamic accuracy?

- | | |
|--|--|
| <p>a) Dynamic response of the system</p> | <p>i) Natural frequency of the system (F_n)
ii) Damping coefficient (D)</p> |
| <p>b) Other factors</p> | <p>iii) Noise (<i>electrical or mechanical/vibration</i>)
iv) Physiological reactance (<i>eg the recording system itself affects the pressure in the artery</i>)</p> |

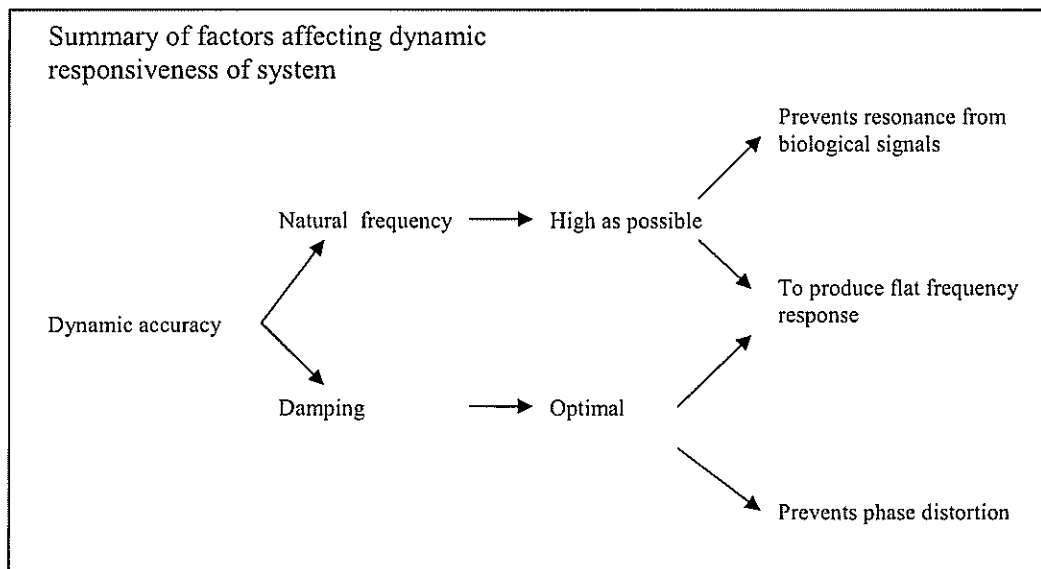

Natural frequency

Why do you want a high F_n ?

1. The F_n should be higher than the frequency of the biological signals measured or the latter will cause the system to resonate and distort.
2. The F_n has to be high enough to ensure that the flat frequency response produced by optimal damping encompasses the first 10 harmonics.

What physical principles determine the natural frequency of the system?

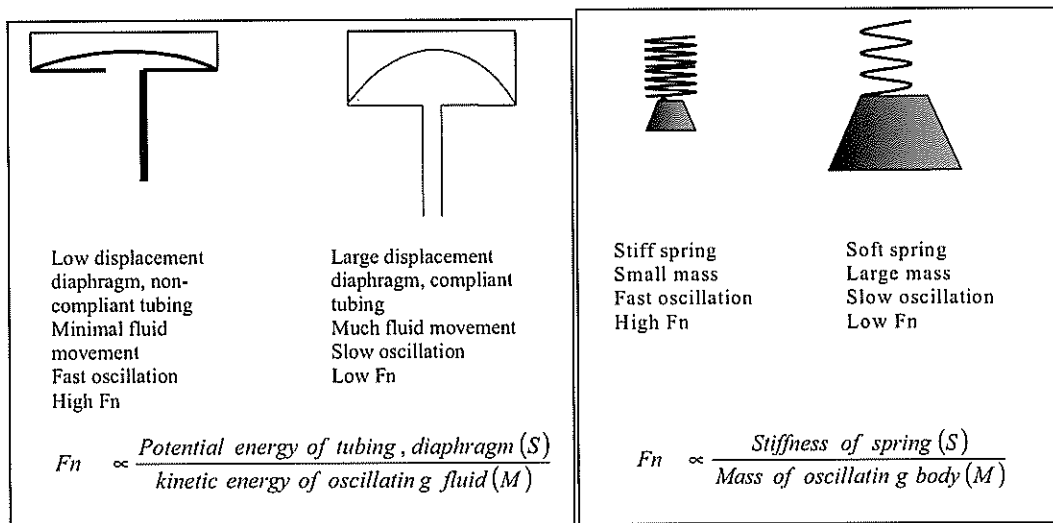

Therefore, to ensure high natural frequency:

S Stiff, non-compliant tubing and diaphragm
M Reduce the kinetic energy of the pulsing fluid by using short, wide, non-compliant tubing and low density fluids.

Rules of thumb

- Should be at least 40 Hz (Ref: Kenny and Davis)
- Should be at least ten times the fundamental frequency (Ref: Al-Shaikh)
- Should be at least 1/4 of the heart rate measured

'Optimal' Damping

All transducing systems have a degree of damping. The performance of the system is determined by the balance between F_n and damping. Damping will minimise the amplitude exaggeration of high frequencies and also suppress unwanted resonance if it occurs. Most of our pressure monitoring systems are actually underdamped rather than optimally damped but this doesn't matter if the F_n is so high that resonance is unlikely. (See later). However, for purposes of understanding we will look at the ideal situation of 'optimal' damping.

Optimal damping coefficient
How much 'overshoot' does this allow?

$D = 0.64$
7 % (see later)

Factors affecting damping

$$D \propto \frac{\text{Tubing length. Fluid viscosity. Volume of displacement}}{\text{Tubing diameter. Fluid density}}$$

What properties does *optimal* damping give?

- i) Flat frequency response to 2/3 of F_n
- ii) Minimal Phase distortion

Flat frequency response (FFR)

Principle

When recording a complex sine wave, the component frequencies are amplified to differing degrees. The closer the frequency is to the F_n , the more exaggerated is its amplification. This will result in distortion of the complex sine wave. (See diagram below)

Flat frequency response

For accurate arterial pressure monitoring, the system should be designed to have minimal amplitude distortion (no more than 2% amplification) up to the 10th harmonic. (In fact, for our purposes, a FFR up to 6-8th harmonic is usually adequate)

Achieving a FFR

A FFR will occur when optimal damping is applied in a system with an adequately high F_n . Optimal damping results

in all harmonics up to 2/3 of the F_N being reproduced within 2% of their original amplitude.

A FFR to 2/3 F_N will however only correspond to the first 10 harmonics if the F_N is high enough.

For example, if the heart rate is 60 min^{-1} (1 Hz) and there is optimal damping, the F_N must be at least 15 Hz. If the heart rate is 120 min^{-1} (2 Hz), the F_N must be 30 Hz. A quick estimation of the required F_N can be made by dividing the heart rate by 4

F _N must be high enough to ensure an adequate FFR even in presence of optimal damping					
HR	Fundamental frequency	Requirement (10 th harmonic)	Would these F _N be adequate?	2/3 F _N	Does this satisfy standard?
60/min	1 Hz	10 Hz	12 Hz?	8 Hz	No
			15 Hz?	10 Hz	Yes
120/min	2 Hz	20 Hz	15 Hz?	10 Hz	No
			24 Hz?	16 Hz	No
			30 Hz?	20 Hz	Yes

Do we have optimally damped systems?

No, pressure monitoring transducer systems come out of the packet under-damped. This doesn't matter if the F_N is high enough.

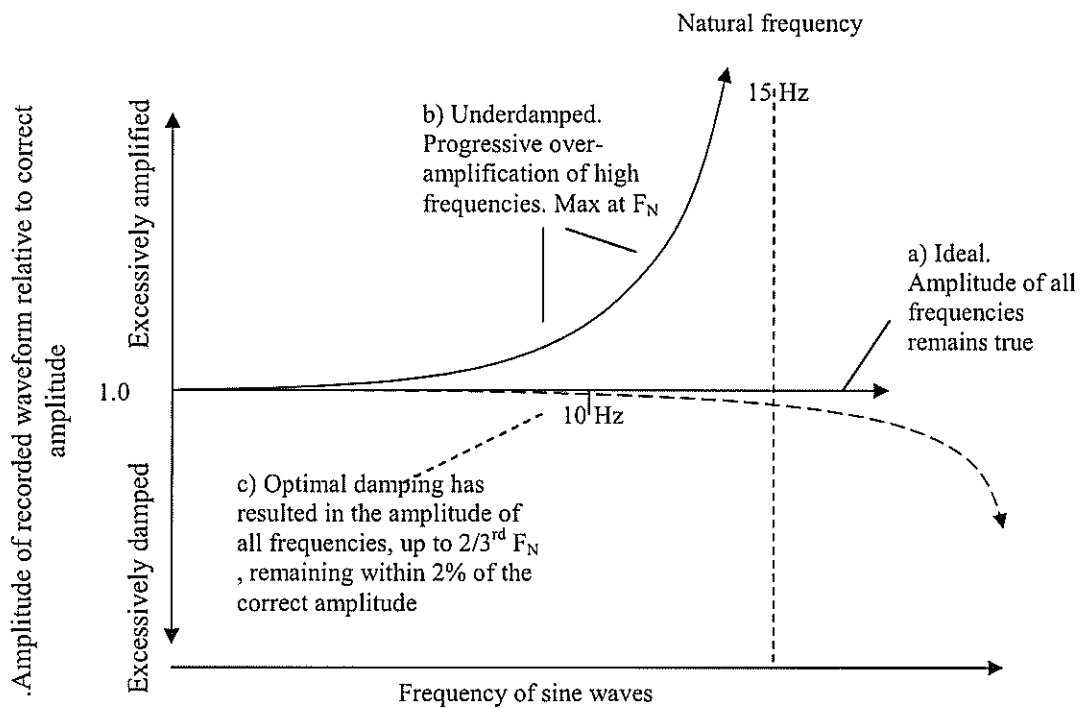
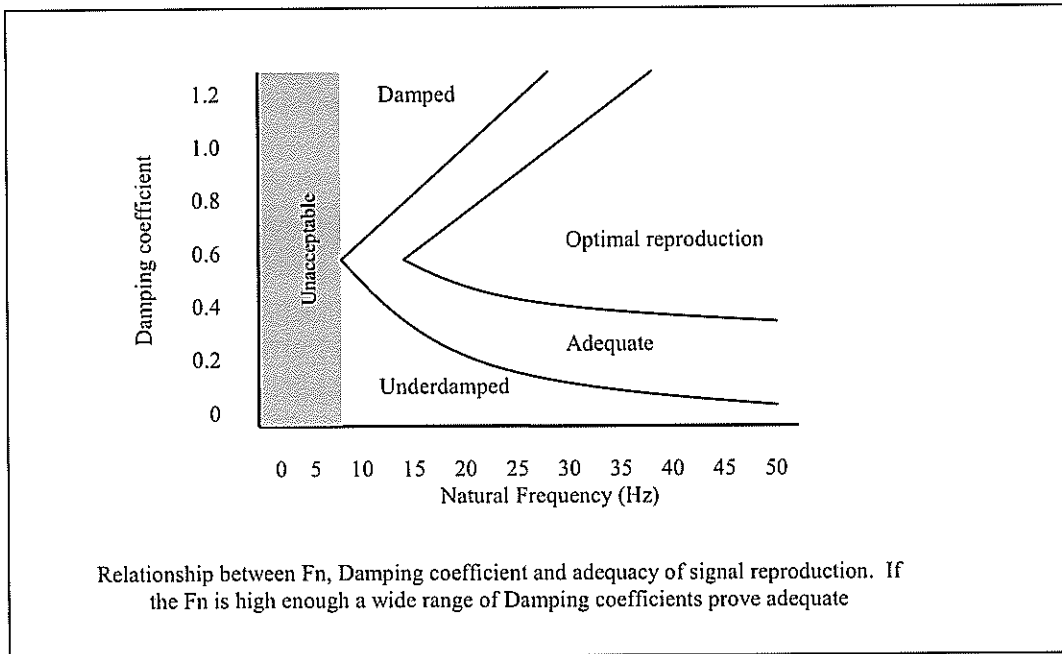

Illustration of how component sine waves are progressively amplified as their frequency increases. Three scenarios depicted: a) ideal where all frequencies remain true to the original, b) under-damped and c) optimal damping.

Although a system with a damping coefficient of 0.64 is optimal, a system which is relatively under or over-damped will still reproduce pressure waveforms reasonably accurately if the F_n is high enough. This is illustrated in the diagram below.



2. Phase distortion

There is a time delay from the occurrence of the pressure wave in the artery and its display on the monitor. This doesn't matter if all the component waveforms of the sine wave are delayed in phase with each other. If they are not, distortion will occur. Phase distortion is largely prevented if the damping is optimal ($D = 0.64$). At this coefficient, *phase lag will be directly proportional to the frequency*

What is meant by 'phase lag will be directly proportional to frequency'?

The time delay of a sine wave can be expressed in terms of the phase of its cycle. Thus, a time delay on a 1 Hz sine wave might lead to a 90° shift in phase. For a 2 Hz component to be delayed by the same time period, the phase shift would have to be 180°

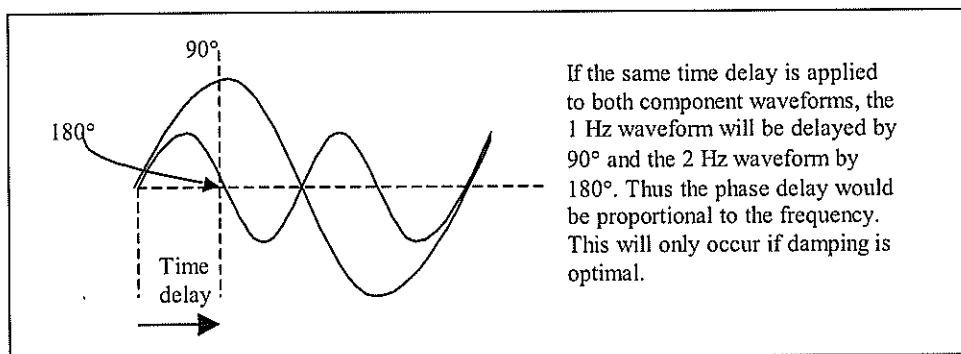

Checking damping and estimating the damping coefficient

How do you do it?

1) Observe overshoot in response to fast flush

2) Measure amplitude ratio and natural frequency and obtain damping coefficient from graph.

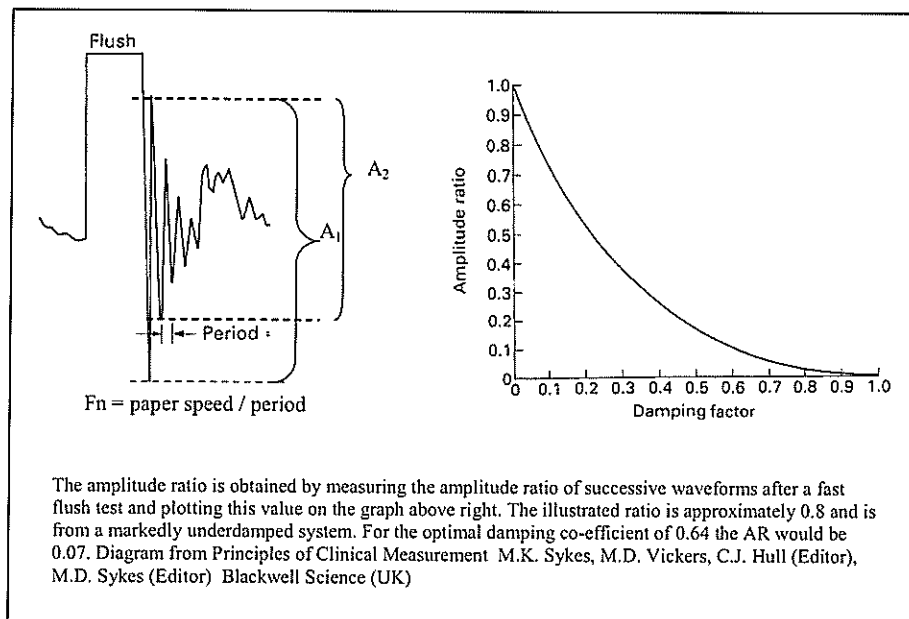
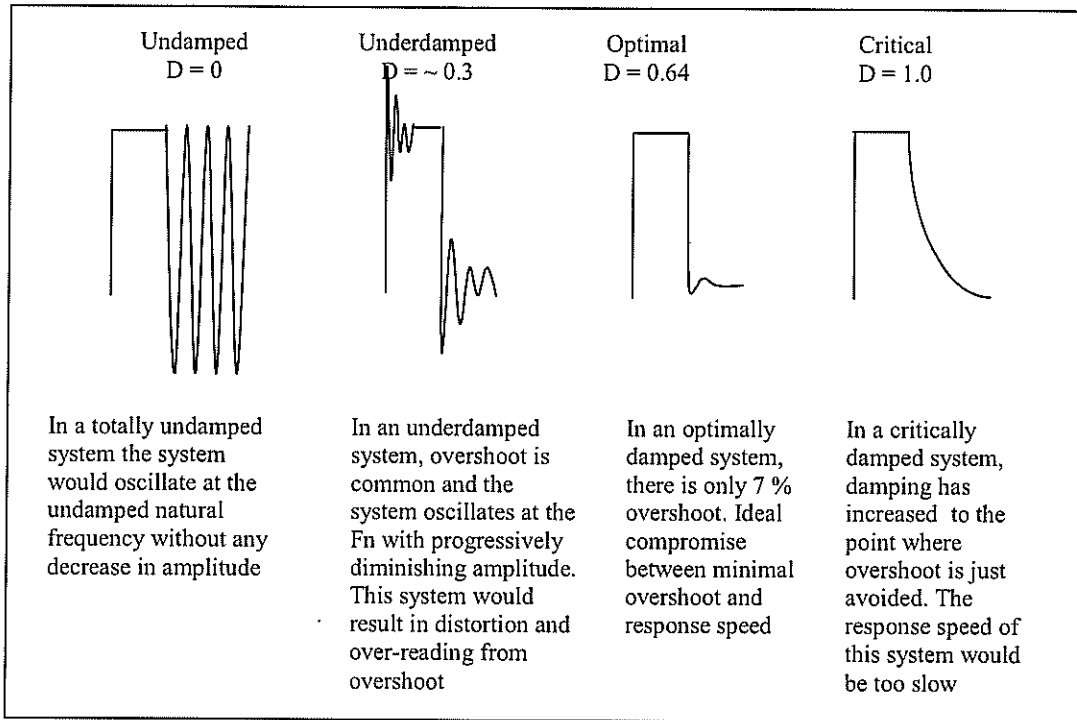

How do you work out the natural frequency?

Divide the paper speed (mm. s^{-1}) by the distance between successive peaks (the period) (mm)

How can damping be adjusted?

- 1) Electrical - frequency sensitive filters
- 2) Hydrostatic - add constriction, 'CorrecTorr'
add compliant tube
air bubble - 'Accudynamic',

Practical considerations in accuracy

Zeroing and calibration (see before)

Placement of transducer at RA level

Use of low compliance components

Avoidance of air bubbles as these increase damping and decrease F_n

Avoidance of clots by Interflow continuous flushing (4 ml.hr^{-1}) and often heparinised saline

Avoidance of kinks

Choice of artery. Peripheral arteries have higher systolic, lower diastolic and lower mean pressure

CENTRAL VENOUS PRESSURE

Applications

As an estimate of blood volume / cardiac filling	Diagnostic purposes eg oliguria, hypotension, tachycardia Direct fluid replacement -where large volumes are being exchanged (severe haemorrhage) - where fluid balance particularly important (renal failure, LVF, respiratory disease)
Drug, TPN administration Pacing wire, S/G catheter Aspiration air embolism Dialysis Inadequate venous access	

Information from CVP line

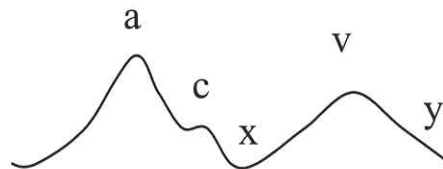

a wave -	atrial contraction; ~ LVEDP
c wave -	bulging of TV into RA during ventric. systole (Miller, Ganong)
x descent -	atrium relaxation
v wave -	passive atrial filling
y descent -	tricuspid valve opening
mean pressure -	'volume status'

Pathology

Cannon waves -	TS, CHB, other AV dissociation
Large 'c-v' wave -	TI
Rapid 'y' descent -	Constrictive pericarditis
Slow 'y' or 'x' descent	TS
Absent 'a' wave	Atrial fibrillation
Is CVP a reliable indicator of filling pressure?	Only if PVR normal and LV and RV function are LV matched.

Complications

Vascular -	Carotid damage Haematoma Thrombosis
Thoracic -	Pneumothorax Hydro- Haemo- Chylo- Tracheal damage Oesophageal
Heart-	Arrhythmias Air / FB embolism Pericardial effusion
Neural -	Phrenic nv palsy Brachial plexus Horner's syndrome (SG) Vocal cord paralysis
Infection	Abscess / sepsis

Practical points

Which vessels?

IJV
EJV Use J wire
Problems with the valves
Introducer can damage SC vein
SC vein increased risk of pneumothorax
Antecubital vein (thrombosis, -phlebitis)
Femoral - increased risk of infection ?

Zero reference points (patient supine)

1) MAL opposite 4th CC
2) sterno-manubrium (add 5 cm)

Length of catheter

Aim to measure at junction of SVC and RA (= 'CVP')
On average ~ 12 cm from skin

When during cycle?

'a' wave peak at end-expiration.

If electrical mean used during IPPV

Overestimation of RA pressure because of contribution of intrathoracic pressure

PULMONARY ARTERY CATHETERISATION

Basic principles

Pulmonary artery (PA) catheter

The PA catheter is a 50 cm long catheter. It has a thermistor 4 cm from tip and three lumen; an air filled lumen for inflation of a ~1.5 cc balloon at the tip, a proximal lumen 30 cm from the tip which sits in the right atrium (RA) and a distal lumen which opens distal to the balloon.

How is it used?

After flushing with heparinised saline the PA catheter is inserted through a central vein sheath while monitoring the distal lumen pressures. Once in the RA, the balloon is inflated and the catheter is floated through the right ventricle (RV), out through the pulmonary valve and into the left main pulmonary artery (MPA). The catheter should not be advanced >10-15 cm without a change in waveform. When the catheter is advanced further the balloon will become wedged in a smaller PA. At this point the pressure recorded at the distal lumen is termed the pulmonary artery occlusion pressure (PAOP) and is the pressure in the pulmonary veins. This is colloquially known as the 'wedge pressure' (PCWP). This pressure reflects left atrial pressure and, in the absence of an abnormal mitral valve, left ventricular end diastolic pressure (LVEDP). With normal LV compliance, the LVEDP should reflect LV end-diastolic volume (LVEDV).

NB. It is vital that the balloon is not left inflated for more than 30 secs at a time.

PA wedge pressure semantics.

Strictly speaking, PA wedge pressure is the pressure recorded by a catheter wedged without the balloon inflated. This situation occludes a smaller proportion of the pulmonary vascular bed than the above and results in a pressure recording that is closer to, but not the same as, pulmonary capillary pressure. However, for safety, you should not attempt to wedge a flotation catheter without prior balloon inflation.

What information can be obtained from a pulmonary artery flotation catheter?

- Direct pressures (eg CVP, RA, RV, PA, PAOP effective pulmonary capillary pressure)
- Estimation of LV filling
- Cardiac output and other haemodynamic parameters (eg SVRI)
- SvO₂ and derived metabolic parameters

Normal pressure trace and values

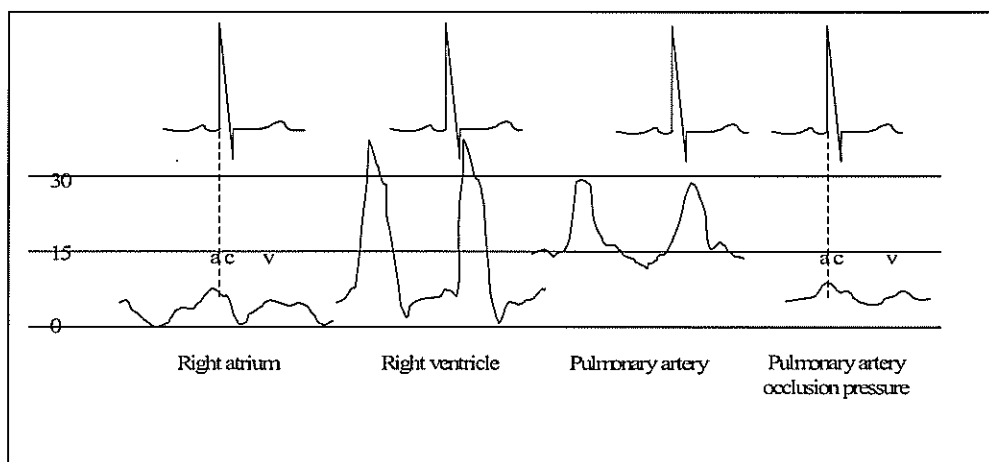

Right atrium	Mean	0 – 8 mmHg
Right ventricle	Systolic	15 – 30 mmHg
	Diastolic	0 – 8 mmHg
Pulmonary artery	Systolic	15 – 30 mmHg
	Diastolic	5 – 15 mmHg
	Mean	5 – 12 mmHg
Pulmonary artery occlusion pressure (PAOP)	Mean	5-10 mmHg (2-3 mmHg higher than RA pressure and < 5mmHg lower than PA diastolic)

PAOP as an indicator of LV filling

Which part of the PAOP trace is the best indicator of LVEDP?

The 'a' wave of the PAOP. The mean LAP (and PCWP) underestimates the LVEDP. See diagram below.

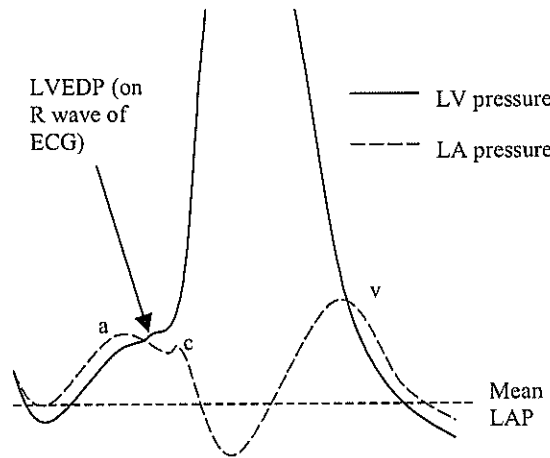

Why is CVP an unreliable indicator of LV filling?

1. Relies on a completely free conduit through West Zone III (See Vender diagram and table below)

Pathologies that invalidate assumptions of pressure relationships from right to left heart					
Relationship	CVP α PA diastolic	PA diastolic α PAOP	PAOP α LAP	LAP α LVEDP	LVEDP α LVEDV
Pathologies which may cause error	Diastolic RV pressure- volume relationship; Tricuspid disease	Pulmonary vascular resistance; Heart rate	Alveolar pressure Pulmonary venous disease	Mitral valve disease Heart rate	Diastolic LV pressure- volume relationship

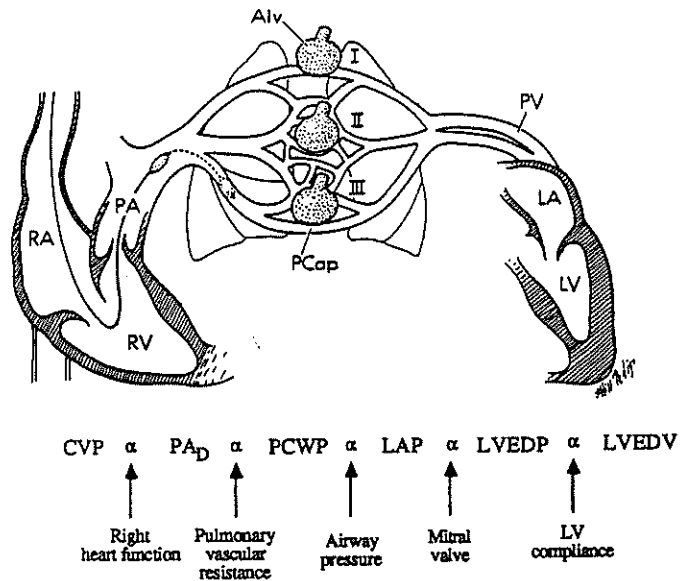

2. Fluid challenges may make large differences to stroke volume before any change in CVP

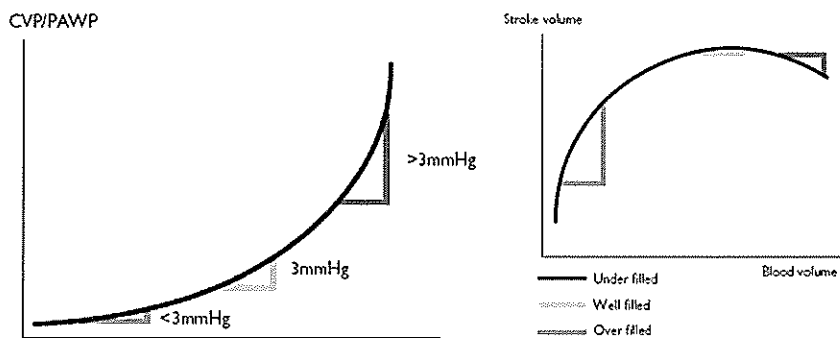

In an underfilled patient fluid boluses may increase stroke volume but have little effect on CVP. Boluses at the peak of the Starling curve may have little useful effect on SV but produce small changes in CVP. If large changes occur in response to fluid loading it may be because we are in the descending part of the Starling curve

Some clinical applications of the Pulmonary Artery Catheter

Where accurate manipulation of filling pressure and cardiac output is desirable	Eg Severe LV dysfunction or sepsis + likelihood of haemodynamic instability																
Diagnostic	Murmurs (ASD, VSD, TI, MR, PS) Inappropriate tachycardia, hypotension, oliguria Constrictive HD, RV dysfunction Pulmonary oedema vs ARDS Shock: Distributive v hypovolaemia v cardiac																
Optimisation of O ₂ delivery in RIRS (ala Shoemaker and Edwards 1980's)	<table border="1" style="width: 100%;"> <thead> <tr> <th>Parameter</th> <th>Normal</th> <th></th> <th>Aim</th> </tr> </thead> <tbody> <tr> <td>CI</td> <td>3.2 l.min⁻¹.m⁻²</td> <td>→</td> <td>4.5</td> </tr> <tr> <td>DO₂</td> <td>600 l.min⁻¹.m⁻²</td> <td>→</td> <td>> 600</td> </tr> <tr> <td>VO₂</td> <td>170 l.min⁻¹.m⁻²</td> <td>→</td> <td>220</td> </tr> </tbody> </table>	Parameter	Normal		Aim	CI	3.2 l.min ⁻¹ .m ⁻²	→	4.5	DO ₂	600 l.min ⁻¹ .m ⁻²	→	> 600	VO ₂	170 l.min ⁻¹ .m ⁻²	→	220
Parameter	Normal		Aim														
CI	3.2 l.min ⁻¹ .m ⁻²	→	4.5														
DO ₂	600 l.min ⁻¹ .m ⁻²	→	> 600														
VO ₂	170 l.min ⁻¹ .m ⁻²	→	220														
Monitoring SVO ₂	Drop in SvO ₂ implies ↓ O ₂ delivery or ↑ O ₂ consumption																

Complications

As for CVP insertion
Arrhythmias
Infection (~10% +ve blood cultures after 72 hr)
Catheter knot
Pulmonary infarction
Pulmonary embolism (thrombus, air, teflon)
Pulmonary artery rupture (~0.2 – 0.5 % → 45% mortality). Associated with elderly, prolonged catheterisation, PA hypertension.

PA rupture:	Signs:	Haemoptysis- mild or massive Bronchospasm CXR- infiltration around catheter tip. Contrast will extravasate into parenchyma
	Management ABC	Ventilatory support: isolate lung Reverse anticoagulation Lower PA pressure - lateral position ± pharmacological Surgery

Inaccuracies

1. Intrinsic inaccuracy
Mean PAOP \neq LVEDP
The peak of the 'a' wave is closer to LVEDP but the mean PAOP is a more practical measure.
2. Practical problems
 - a. Catheter tip not in Zone III
Tip should be in Z III for capillary conduit to be open so that $P_v > P_A$. Checks:
 - Catheter tip should be below RA on lateral CXR
 - Should be able to aspirate blood from wedged distal lumen
 - 'a' and 'v' waves should be visible
 - PAOP $<$ PA diastolic
 - Marked respiratory swings in the trace suggests non-Zone 3. Respiratory fluctuations should be less than those of PA diastolic.
 - b. Other problems
 - Tip intermittently not 'wedging'
 - Balloon over-inflated. Gives a ramp-like increase in pressure to top of display scale or PCWP $>$ PA diastolic
 - Catheter whip. Artefact especially likely because of low f_n
 - Damping from thrombus Must use heparinised saline, continual display
3. PAOP overestimates LVEDP
 - IPPV and PEEP (Z III → Z I or II) (See below)
 - Mitral stenosis or regurgitation **
 - Tachycardia (inadequate time for diastolic filling)

-Pulmonary veno-occlusive disease → obstruction to flow in large pulmonary veins

Effect of PEEP on PAOP

- Mean PAOP will be overestimated because of the addition of the increased intra-thoracic press.
Strategies: 1) Measure PAOP immediately after disconnection before the increase in venous return can cause a resetting of haemodynamics. 2) Mathematical correction (See end of chapter) 3) Ignore. Follow trends
- Mean PAOP increases because PEEP has converted Zone III to Zone II or I. Thus, PAOP represents alveolar rather than left atrial pressure. The lower the lung compliance, the less of a problem because less PEEP is transmitted to vasculature. (See appendix)
- There is a true increase in left atrial pressure because PEEP has decreased LV compliance.

4. PAOP underestimates LVEDP

-Non-compliant LV eg myocardial ischaemia. (Exaggeration of the normal difference between mean LAP and LVP. 'a' wave is prominent and may be close)
-Aortic regurgitation (MV closes prematurely → LVP continues to rise after MV closure)

5. Erroneous use of PAOP as measure of pulmonary capillary pressure (PCP).

Is the PAOP = PCP?

No

Can the PCP be derived from PAOP?

Yes, the mean effective pulmonary capillary pressure (mEPCP) is closely related to the inflection point on the decay of the mean pulmonary arterial pressure curve after balloon inflation.

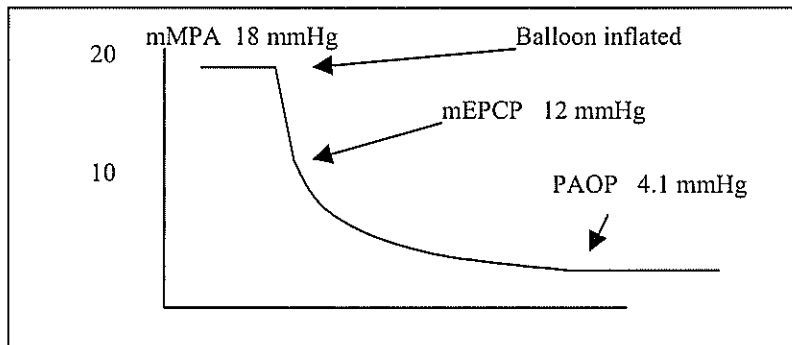

Any other way to derive PCP?

Mathematical estimation using the Garr equation.

PCP (normal patients)

- ≡ PAOP + pressure drop across pulmonary veins
- ≡ PAOP + 0.4 (PA - PAOP)
- ≡ 10 in above example

PCP (ARDS)

- ≡ PAOP + 0.6 (PA - PAOP)

Mathematical correction for PEEP.

For PEEP > 10 cmH₂O, corrected PAOP equals PAOP minus half the quotient of PEEP divided by 1.36

Monitoring mixed venous oxygen saturation

$$S\bar{v}O_2 = SaO_2 - \frac{\dot{V}O_2}{\dot{D}O_2} \quad \text{or} \quad S\bar{v}O_2 = 1 - \text{Extraction ratio}$$

If arterial hemoglobin saturation, oxygen consumption, and hemoglobin concentration remain stable, mixed venous hemoglobin saturation may be used as an indirect indicator of cardiac output. For example, when cardiac output falls, tissue oxygen extraction increases and the mixed venous blood will have a lower oxygen content and lower hemoglobin oxygen saturation. However, if either arterial hemoglobin concentration, O₂ saturation or oxygen consumption change significantly, one cannot assume that a change in mixed venous saturation is a result of a change in cardiac output.

Method	Intermittent blood sampling Reflectance oximetry incorporated into PAC
Advocates	Indication of adequacy of tissue oxygenation Indication of adequacy of cardiac output Surveillance / early warning Guide for adjusting therapy
Critics	SvO ₂ doesn't reflect adequacy of regional oxygenation (<i>one organ can be ischaemic while another has luxury perfusion</i>) Indication of Cardiac output only if other parameters stable Triggers for surveillance not reliably defined Evidence of benefit to outcome lacking

CARDIAC OUTPUT

There are an increasing number of devices capable of giving us an estimate of cardiac output. Many will also provide Stroke Volume Variation (SVV) and/or Pulse Pressure Variation (PPV) which are useful parameters for goal directed fluid therapy. The physical principles most commonly used are Ultrasound, Pulse analysis and Thermodilution.

Most common methods		
Ultrasound	Doppler + 2D ultrasound	
	Doppler alone	eg Cardio-Q
	2D ultrasound alone	Eg Simpson's method
Pulse contour or power analysis	Non-invasive	Finger volume clamp method (Nexfin, Finometer, LiDCO CNAP*)
	Invasive / uncalibrated	eg Vigileo with FloTrac sensor, PiCCO ProAQT, LiDCO rapid*
	Invasive / calibrated	PiCCO, LiDCO plus*
Thermodilution	Intermittent cold boluses	Via PA catheter
	Continuous	eg. Edwards Continuous CO
Others		
Thoracic bioimpedence		
Imaging	Radionuclide	
	MRI	
Fick technique	Classic VO ₂ technique	
	Fick rebreathing attachment during IPPV (NICO)	
	Dye dilution	

*The LiDCO devices analyse arterial pulse power rather than pulse contour.

Other estimates of pump performance

Arterial trace:	slope of dp / dt Systolic time intervals eg systolic ejection portion Amplitude changes
Echocardiography	Ejection fraction

Mixed venous oxygen saturation

Ultrasound

Doppler methods

How is doppler used to estimate CO?

Doppler + 2D ultrasound estimation of Area_{Ao}
Doppler + Biometric (Ht, wt, gender), estimation of Area_{Ao}

Which measurements are required?

- 1) Cross sectional area of aorta (Area_{Ao}) from 2D echo of ascending aorta or normogram approximation of descending Ao with TOE.
- 2) Ave. velocity of blood flow for each heart beat (V_{avg})
- 3) Time period for ejection during each beat (T_{ej})
- 4) Heart rate

$$CO = Area_{Ao} \cdot V_{avg} \cdot T_{ej} \cdot HR$$

What is the Doppler effect and how is it used to measure velocity?

See Ultrasound chapter

Inaccuracies/problems

Misalignment of beam (angle must be known)

Inaccuracies in estimation Area A_o
 Artefact from respiration
 Abnormalities of aorta / aortic valve
 Trauma from probe

Applications

Suprasternal (ascending aorta)
 Transoesophageal (descending aorta)
 Transtracheal
 Intrathoracic

Oesophageal Doppler assumptions

The estimation of CSA is close to the mean value in systole
 The probe is lying parallel to the aorta
 Constant division of flow between Descending aorta (70%)
 and Brachiocephalic + Coronary arteries (30%)
 Negligible diastolic flow
 Flat velocity profile (all RBC's moving at same speed?)

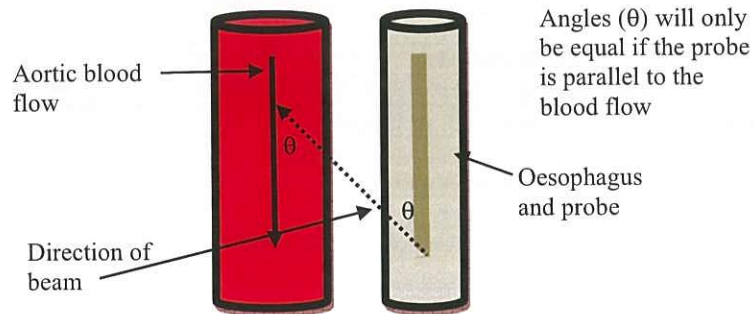

CardioQ oesophageal doppler

Basis

An oesophageal Doppler probe is inserted to 40 cm (oral) or 45 cm (nasal). The probe is rotated to give the clearest and sharpest pitch, with brightest colour and tallest peak. Velocities are measured and an algorithm based on weight and height allows estimation of cardiac output. The manufacturers heavily weight the role of the device in directing fluid therapy in theatre and, in particular, the effect of volume status on the "Flow Time corrected" (FTc). They propose that the width of the base of the Doppler waveform, corrected for heart rate, is shortened when SVR is increased, the most usual cause of the latter being hypovolaemia.

Measurement of cardiac output using 2D-ultrasound alone

Basis

Based on Simpson's rule which 'cuts' the ventricle into multiple elliptical discs. If the volume and EF of each disc is estimated, their sum will equal the ventricular volume and stroke volume respectively. In reality, one cross-sectional view is taken, the ejection fraction is noted and the volume is calculated based on a standard bullet-shaped ventricle. Simpson's rule also used in contrast ventriculography.

Dilution techniques

Fick principle

Fick principle

The amount of a substance taken up by an organ or whole body over a period of time, is equal to the arterial concentration minus the venous concentration times the blood flow over the time period.

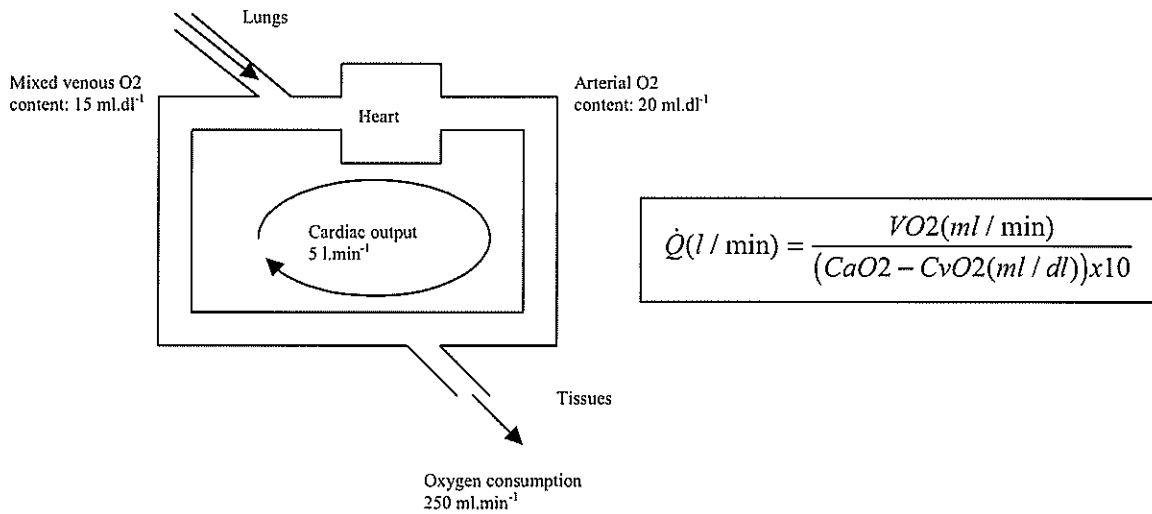

Problems:

Errors in sampling and analysis of oxygen
 Estimation of VO_2 - Spirometry cumbersome
 - Metabolic computer
 Changing \dot{Q} during sampling time
 Changing respiratory conditions

VO_2 calculation by metabolic computer (*main problem occurs in determining inspired MV*)

$$VO_2 = (V_i \times F_i O_2) - (V_E \times F_E O_2)$$

Where V_E = expired MV
 V_i = inspired MV (This differs from expired and is usually calculated from V_E thus:

$$V_i = V_E \times (N_E / N_i)$$

Where N_E = expired $[N_2]$
 N_i = inspired $[N_2]$ (The difference \propto the total amount of N_2 absorbed)

Dye dilution and Thermodilution

Fundamental difference from classic Fick

Basic principle

Bolus of indicator

A mass of indicator is given into a central vein and the blood flowing by dilutes it. The rate of dilution is measured and depicted as a concentration-time curve. The AUC is inversely proportional to the cardiac output.

Basic form of equation

Cardiac output = Mass added / AUC

Dye dilution

Indicator -	Usually indocyanine green. Others include Evans blue, methylene blue, bromsulphalein, Lithium (LiDCO see later).
Injected into -	Central vein
Sampling-	Via radial artery at two second intervals or continuous using densitometer / ion-sensitive electrode
Calculation (see below)	Cardiac output = Mass added / AU concentration-time curve
Problems-	Continuous sampling from radial artery Gradual build-up of dye Recirculation 'hump' - especially with intra-cardiac shunt. ∴ Calculation based on log scale

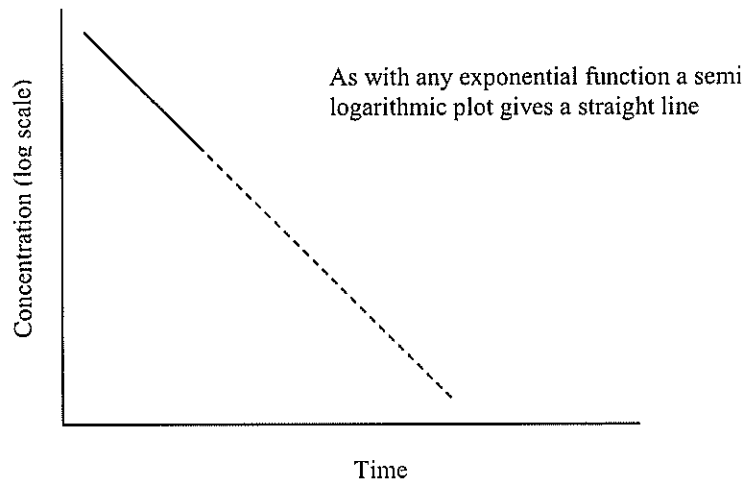
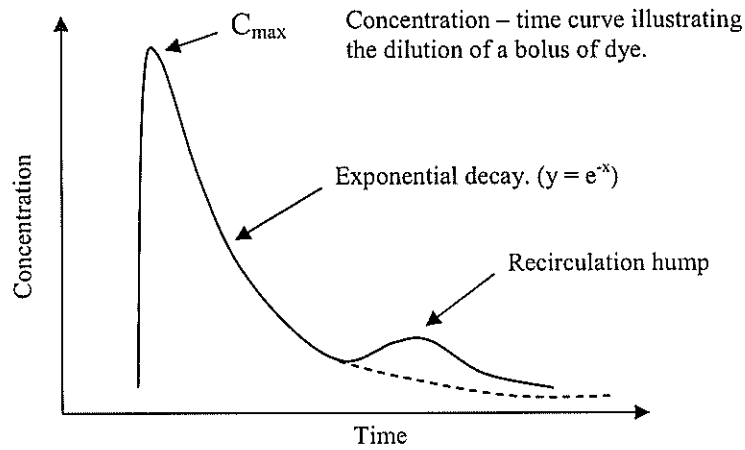

Thermodilution using PA floatation catheter

Indicator -	A mass of cold
Advantage	No recirculation hump
Sensor -	Intravascular thermistor

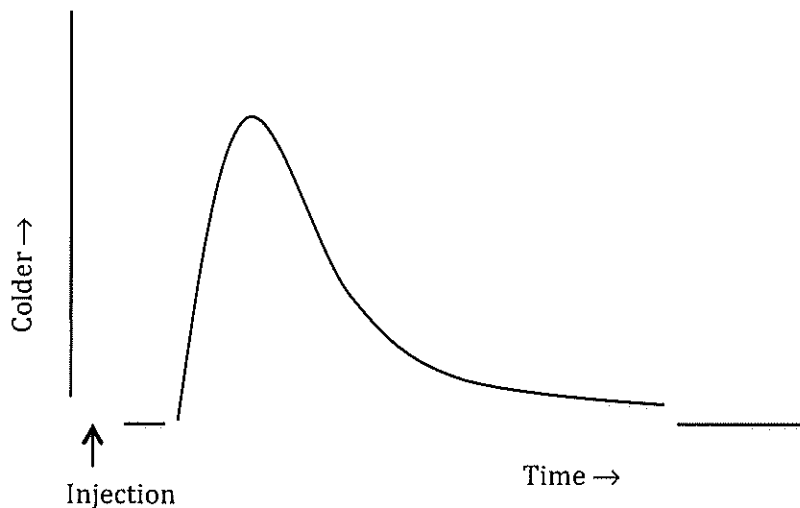

Basic principle

A 'mass coldness' is injected as a rapid bolus into the RA via the proximal port of a PA catheter. The thermistor in the MPA measures the rate of dilution of the cold bolus and this is depicted in a temperature-time curve. The AUC is inversely proportional to cardiac output

Basis of calculation:

This is the conservation of mass principle. If you know the mass of dye or 'coldness' and you know the concentration after dilution, you can work out the volume of diluent.
Volume = Mass added / Concentration

The added factor here is that the diluent is flowing by over a time period.

Flow (Q) = Mass added / Mean concentration x Time

The denominator of the above equation is the AUC:

Cardiac output = Mass added / AUC

The mass added is a 'mass of coldness'. How is this accounted for?

- Difference between body and injectate temperature
- Volume of injectate (usually 10 ml)
- A constant (k) derived from volume, density, temperature and specific heat capacity of injectate

Cardiac output = $V(T_B - T_I)k / AUC$

The Stewart Hamilton equation is completed using the integration notation for AUC

$$\dot{Q} = \frac{V(T_B - T_I)k}{\int_0^{\infty} \Delta T_B(t) dt}$$

*I recommend starting the explanation of the calculation using the simple equation:

Cardiac output = Mass of cold added / AUC

Accuracy 3 - 13 % variability compared with direct electromagnetic flow measurement.
Thermodilution remains the gold standard, against which newer techniques are validated.

Points:

- a) Extrapolation: In both dye- and thermo-dilution methods the dilution curve is extrapolated after it has decayed to 25-30% of peak. This is to control for a) the recirculation hump in dye dilution and b) the fact that temperature varies in the RV during respiration so it is difficult to determine when the curve reaches baseline. (There is normally a difference in temperature between the IVC and SVC and the fraction of venous return from these veins varies with respiration. This causes a variation in temperature in RV with respiration.)
- b) Even if the total cardiac output does not pass the sampling site, the change in indicator concentration is the same in every arterial branch. Thus the AUC will be the same in any part of the circulation.
- c) Iced injectates: Some believe that the lower the injectate temperature, the greater the signal to noise ratio and the greater the accuracy, but this is not always confirmed and rapid injections of cold fluid can also lead to bradycardia. Iced injectate may also spuriously increase contractility and CO as a consequence of reduced temperature in coronary circulation. Iced injectate is sometimes thought to be better in ventilated patients where PA temperature varies more with respiratory cycle.
- d) Volume: The larger the volume (ie 10 ml rather than 5 ml) the greater the reproducibility
- e) The injection must be smooth, rapid injection. Reject uneven curves (∴ visual display of curves essential)
Mean of three consecutive Q determinations not differing by more than 10 %
Ideally injection should be instantaneous but ≤ 4 sec is acceptable.
- f) 5 % Dextrose rather than Saline
- g) Time injections to particular point in respiratory cycle? - No, very difficult anyway.
Four injections spread evenly through ventilatory cycle? - Maybe.
- h) Clinical situations when results may be invalid: Tricuspid incompetence esp. with IPPV. Underestimat".
R → L intracardiac shunt
Rapid infusion into SVC
Haemodialysis
RA port lies within sheath.

Edwards Continuous CO

Principle Thermodilution by heat dissolution
PAFC with thermal coil. When correctly positioned the coil lies in the right ventricle. Intermittent discharge of heat picked up by distal thermistor.
Background changes in temperature are assessed by analysing cooling of random heat pulses. This causes a delay and the monitor gives the average CO over several minutes.

Advantage Convenient
Continuous estimation of cardiac output
Safety - less three way taps and less handling → less disconnection and infection

Example Edwards Vigilance II monitor. Standard cold thermodilution is also possible with this device.

Pulse contour and Pulse pump analysis

General points

There are increasing numbers of these devices because of:

- Global interest in goal directed fluid management
- The acknowledgement that CVP is a misleading measure of LV filling (see PA catheter chapter)
- A drive towards less invasive estimates of cardiac output and filling pressure

Pulse pressure variation (PPV) and stroke volume variation (SVV)

- These are increasingly popular indices of adequacy of LV filling and the likelihood of responsiveness to fluid boluses.
- $\Delta PPV \% = PP \text{ difference} / \text{Average PP} \times 100$
- $\Delta PPV \% = (PP_{\max} - PP_{\min}) / (PP_{\max} + PP_{\min}) / 2 \times 100$
- $PPV < \sim 13\%$ suggests the patient is unlikely to be fluid responsive
- $SVV < 10\%$ suggests the patient is unlikely to be fluid responsive

Accuracy

- The PA catheter remains the most accurate measure of CO and remains the gold standard with which continuous devices are compared.
- Alternative minimally or non-invasive devices are less accurate and have percentage errors of between 40 and 50% on average (See Peyton et al 2010 and Imhoff 2013). Acceptable standards have previously been set at 30%.
- Pulse contour devices require some indication of vascular compliance. This is achieved in some by prior calibration by a dilution technique (more accurate) and in others by a body mass algorithm (less accurate).

Monitors of cardiac output using pulse contour or pulse pump analysis

	Calibrated	Uncalibrated
Lithium dilution	LiDCO ^{plus}	
Pulse contour analysis	PiCCO	PiCCO ProAQT LiDCOrapid FloTrac Masimo SET
Volume clamp		Pleth variability Index CO, PPV, SVV

CO = Cardiac output, PPV = pulse pressure variation, SVV = stroke volume variation

'Pulsion' Pulse Contour Cardiac Output (PiCCO)

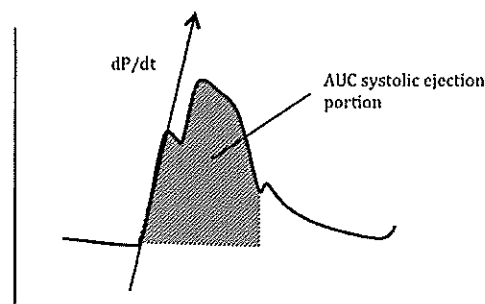

Two major components of pulse contour analysis

Basis	Measurement of cardiac output and circulatory variables by intermittent thermodilution and continuous arterial pulse contour analysis.
Principles:	<ol style="list-style-type: none"> 1) A bolus of cold saline or dextrose is injected through a CVP line and the thermodilution is measured by a peripheral (femoral) arterial catheter 2) The arterial pulse is simultaneously analysed. Parameters include:

Heart rate
dp / dt slope
AUC systolic ejection portion
Estimate of aortic compliance

3) Cardiac output is thereafter continuously estimated by pulse contour analysis.

How is aortic compliance estimated?

Estimated from thermodilution transit times and arterial waveform diastolic decays during calibration. In uncalibrated devices it is estimated from patient biometrics and the diastolic decays of the arterial trace.

Other derived indices

Intrathoracic blood volume
Extravascular lung water

How are these obtained ?

The volume parameters are highly derived and obtained from the transpulmonary thermodilution. The basic principle is to multiply the cardiac output by various characteristic time variables of the thermodilution curve. These include the mean transit time and the exponential downslope time.

Significance of ITBV?

ITBV is said to be a sensitive indicator of cardiac preload compared to CVP or PAOP.

Significance of EVLW?

EVLW is said to be “ the only determinable bedside parameter with which the lung status, respectively the pulmonary permeability damages can be quantified, especially when the pulmonary oedema has been caused by pulmonary vascular permeability” (PULSION medical systems)

LiDCOplus

The LiDCO^{plus} also produces a continuous estimation of cardiac output through analysis of the arterial pressure but is prior calibrated using lithium dilution rather than thermodilution. A small, non toxic, dose of Lithium is given through a central line or peripheral line and its dilution measured at a lithium selective electrode attached to a radial artery sampler. This calibrates simultaneous pulse analysis and allows subsequent continuous derivation of the cardiac output from the arterial line trace.

Pulse power analysis

The arterial analysis differs from PiCCO and is termed pulse power analysis. Based on the correlation between stroke volume and the power of the arterial waveform rather than the morphology of the arterial trace

Problems

As the lithium dose is small this technique is not possible in Lithium users.
Contraindicated in 1st trimester of pregnancy
Readings may be upset by some muscle relaxants, particularly benzylisoquinoliums.

Uncalibrated invasive pulse analysis

These methods require an arterial line but no prior thermodilution calibration.

PiCCO ProAQT

Pulse contour analysis via a radial artery cannula connected to the ProAQT transducer. Prior thermodilution calibration is

not used and aortic compliance estimated from arterial waveform decays and biometric values.

'Vigileo' Flo Trac (Edwards Lifesciences)

Pulse contour analysis via a radial artery cannula connected to the Flo Trac sensor. Body surface area and estimates of arterial compliance supposedly negate the need for prior thermodilution calibration.

LiDCOrapid

LiDCOrapid monitor and transducer attaches to standard arterial cannula and estimates CO, PPV and SVV by pulse power analysis. No Lithium involved

Uncalibrated non-invasive pulse analysis (Volume clamp method)

Nexfin

The pulsatile change in blood volume in the finger is matched by a counter force so that the finger artery is 'clamped' at a fixed diameter. The pressure required to do this is measured continuously. This is called the '*volume clamp principle*'. A photo-plethysmograph is able to detect arterial blood volume (wavelength set at oxygenated blood) → rapid feed back to pneumatic cuff which inflates and deflates rapidly to 'clamp' the artery at a fixed volume
→ the pressure in the cuff required to achieve this is continuously displayed.
→ pulse contour analysis estimates CO, PPV and SVV

LiDCO CNAP

This is a non-invasive volume clamp model with pulse power analysis. Thus, neither lithium nor arterial lines are required.

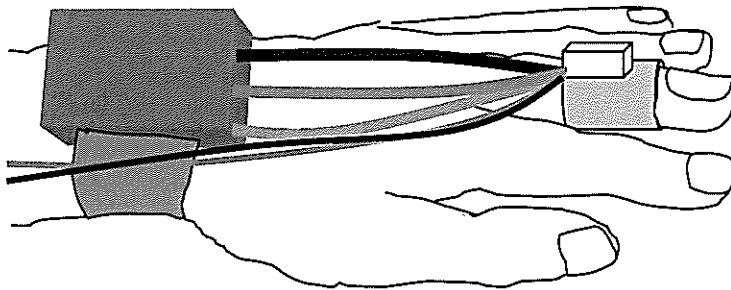

Other methods

Thoracic bioimpedence

Basis

The electrical impedance of the thoracic cavity is inversely related to thoracic blood volume. Thus, as the latter changes with each ejection of blood during cardiac systole, the thoracic impedance is inversely related to stroke volume.

Device

'Physio Flow' *Manatec Biomedical*

Technique Six 'ECG-type' electrodes are placed on chest and side of neck.
Impedance measured from small current across chest

Problems Decreased accuracy with ↑ HR
Decreased accuracy with ↓ pulsatility - sepsis, haemodilution
Decreased accuracy with intra-cardiac, intra-thoracic shunts
Interference from electrocautery
Difficult with upper body surgery

NICO
Basis

If elimination of CO₂ is prevented, the rise in ET CO₂ is related to the rate of venous CO₂ delivery to the lungs
The NICO (Novamatrix) system is a non-invasive device that applies Fick's principle on CO₂ elimination and relies solely on airway gas measurement in the breathing circuit and relies solely on airway gas measurement in the breathing circuit.
Over a fixed period of time the amount of CO₂ leaving the lungs in the arterial blood is equal to the amount brought into the lungs in the venous blood minus the amount eliminated through the lungs. (The method actually calculates effective lung perfusion, i.e. that part of the pulmonary capillary blood flow that has passed through the ventilated parts of the lung, and so significant V/Q mismatch reduces accuracy).

Method (simplified)

The device is attached to patient breathing system and includes a rebreathing circuit which is intermittently connected to patient.
Principal measurements: ET CO₂ and Volumetric CO₂ elimination made during normal breathing (NB) and 35 sec periods of rebreathing (RB).
The rate of change in ET CO₂ during rebreathing will be related to the cardiac output (actually lung perfusion). CO is proportional to the change in CO₂ elimination divided by the change in end tidal CO₂ resulting from a brief rebreathing period.

Radionuclide

Basis

Not a real time, intraoperative test. Using Tc- 99 scanning, the LV ejection fraction is obtained by calculating the difference between end-diastolic and end-systolic counts and dividing by the end-diastolic counts. The LVEDV is calculated from analysis of the blood pool image. CO is calculated from the product of LVEDV, EF and HR.

MRI

Basis

Cardiac output can be measured by cine-phase contrast MRI imaging

DERIVED HAEMODYNAMIC AND METABOLIC PARAMETERS

VARIABLE	DERIVATION	NORMAL VALUE
Cardiac output	SV x Heart rate	5 litres.min ⁻¹
Cardiac index	CO / BSA	3.2 l. min ⁻¹ m ²
Stroke volume	CO / HR x 1000	80 ml
Stroke index	SV / BSA	50 ml. m ²
Systemic vascular resistance (SVR)	$\frac{MAP - CVP \times 80}{CO}$	1000-2000 dynes. s cm ⁻⁵
Systemic vascular resistance index (SVRI)	$\frac{MAP - CVP \times 80}{CI}$	1300 - 2600 dynes.s cm ⁻⁵ m ²
Pulmonary vascular resistance (PVR)	$\frac{MPA - LAP \times 80}{CO}$	60 - 120 dynes. s cm ⁻⁵
Left ventricular stroke work index (LVSWI)	$1.36 \frac{(MAP - LAP) \times SI}{100}$	50 - 60 g. m. m ²
Rate pressure product	SBP x HR	
Ejection fraction	$\frac{\text{End-systolic volume} - \text{End-diastolic volume}}{\text{End-diastolic volume}}$	> 0.6
* Oxygen content	Hb x SO ₂ x 1.39 + (PO ₂ x 0.003)	18 - 20 ml / dl
Oxygen delivery (DO ₂)	CO x CaO ₂ x 10	850 - 1050 ml / min
Oxygen consumption (VO ₂)	CO x C(a-v)O ₂	180 - 250 ml / min
Oxygen extraction rate	C(a-v)O ₂ / CaO ₂	20 - 30 %

* If the dyshaemoglobins of methaemoglobin, sulphaemoglobin and carboxyhaemoglobin are not measured, they must be accounted for in the calculation by using the lower Huffer constant of 1.36 or 1.34.

ULTRASOUND

Some Anaesthetic applications in anaesthesia
Measurement of cardiac output (Doppler \pm 2D)
Optimising fluid replacement (Oesophageal Doppler)
Estimation cerebral blood flow dynamics (Transcranial Doppler)
Blood pressure measurement
Central and peripheral venous access
Identification of nerves for regional anaesthesia
Oxygen analysis

Physical principles

What is a sound wave?	A longitudinal pressure wave moving through a medium causing the molecular density to increase (compression) and decrease (rarefaction). Thus a sound wave will not occur in a vacuum and will only pass through low density substances with difficulty.
What is ultrasound?	A sound wave that is above the threshold of human hearing. Normal hearing: 20 Hz - 20 kHz. Ultrasound: 2 – 15 MHz
How is it produced?	Piezoelectric (pressure-electric effect) crystal which expands and contracts when a varying voltage (AC current) is passed across it. Crystal originally quartz but now more commonly ceramic PZT (lead zirconate titanate)
How is it detected?	The opposite of the above. The returning echoes hit and distort the crystal, causing an electric current to be generated. Signals are pulsed. Short outgoing pulse with duration of about one nanosecond followed by a much longer detection phase.
Pulsed signal	The transducer emits signals in pulses. Each pulse contains a number of cycles (usually 2-4). Between pulses the transducer is listening. It is in listening mode ~ 99.4% of the time.
What frequencies (f) are used in echocardiography?	Usually 2.5 – 7.5 MHz. This is the range where there is best compromise between resolution and penetration. Resolution increases with frequency but penetration decreases.
What determines the velocity (v) of the sound wave?	Sound is propagated through different tissues at different velocities. The speed is greatest in <i>non-compliant</i> tissues as the strong bonds between molecules results in greater force of acceleration between neighbouring vibrating molecules. In addition, the <i>lower the mass</i> of the molecule, the greater the acceleration and the faster the sound wave. (eg speed of sound through lead is much slower than through aluminium)

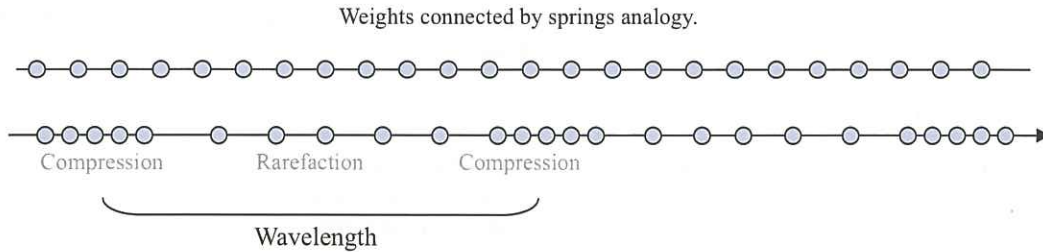

In the weights and springs analogy, sound is transmitted fastest if the weights are of low mass and the springs are stiff.

Density and speed of sound

Density is mass /unit volume. You will see some texts state that speed of sound increases with density and some that it decreases with density. Taking density on its own it is true that speed of sound decreases with increasing density because the greater the mass of molecules on the 'spring' the slower the velocity. But the reality is that as tissues become more dense their compliance decreases proportionately much more. Thus high-density tissues like bone transmit sound waves at high velocity because they are *much less compliant*. If materials have similar density, it is the one with greater stiffness that transmits sound fastest. For example, nickel and bronze have similar density but sound travels faster in nickel because it has greater stiffness.

What would you say in the exam?

High density tissues tend to transmit sound fastest because of their low compliance

Speed of sound through air

330-340 msec⁻¹

Speed of sound through soft tissue

1460 –1630 msec⁻¹ .Average 1540 msec⁻¹

Speed of sound through bone

2700-4100 msec⁻¹

Wavelength, frequency, velocity

Relationship between velocity, frequency and wavelength?

Wavelength = Velocity / frequency
Velocity is determined by the tissue
Frequency is determined by the source
Wavelength is a consequence of the two

Period

The time taken for one cycle to occur

Wavelength

The distance travelled from beginning to end of one cycle.

Energy, power and ultrasound

Amplitude of waveform is measured in dB but the heat energy generated by the vibration is in joules. The acoustic power is the amount of energy per unit time (1 watt = 1 J/sec) and is in the order of milliwatts.
The intensity of the sound beam is the power per unit area.

The Ultrasound image

What causes the US image?

The US detector picks up reflection of the US wave off the interface between tissues of different densities. The greater the density difference, the greater the portion reflected.

How is the depth of the interface measured?

If you assume the average speed of sound through soft tissues is at 1540 ms⁻¹, the depth of the interface can be estimated

from the time taken for the emitted signal to return to the detector.

Attenuation

What is meant by attenuation of the signal?

Loss of amplitude or power of the signal (in dB.m⁻¹) as it travels through tissue. As with light, the loss is exponential in a homogenous tissue.

What causes attenuation?

Absorption of energy by tissue and converted to heat.

What else impairs signal progress?

- a). Diffraction – un-scattered beam diverges and spreads energy over wide area
- b). Reflection – referred to as ‘specular’ echoes
- c). Refraction - beam is spread by refraction at a curved interface. As with light, degree of refraction related to ratio of velocities at the interface. Of minimal importance as most tissues have similar velocities.
- d). Scattering – Occurs in non-homogenous tissues. Increases with frequency but particularly when target scatterer is of smaller diameter than wavelength.

What does attenuation depend on?

- Distance travelled
- Frequency of beam
 - ↑ molecular motion → ↑ heat production
- Type of tissue traversed
 - Highly viscous tissues result in more heat production
 - Tissues which relax slowly after an US pulse collide with the next pulse → more heat production .

Equivalent equation for attenuation	$I_x = I_o e^{-\alpha x}$ <p>Where <i>I</i> is the intensity of the US beam. Intensity being the energy carried by the beam through the unit area per second. Where α is the attenuation coefficient. Where <i>x</i> is the distance traversed by the beam</p>										
What is the attenuation coefficient (α) ?	<p>The <i>fractional change</i> in intensity of the beam per unit distance traversed. (∞) May also be expressed as the number of dB that are attenuated per metre of tissue. (Here it is termed μ with units dB.m⁻¹ [$\mu = 4.3\alpha$])</p>										
Attenuation coefficient (μ) for a 1MHz beam	<table> <tr><td>Blood</td><td>20 dB m⁻¹</td></tr> <tr><td>Fat</td><td>60 dB m⁻¹</td></tr> <tr><td>Soft tissue</td><td>70 dB m⁻¹</td></tr> <tr><td>Liver</td><td>90 dB m⁻¹</td></tr> <tr><td>Muscle</td><td>180 dB m⁻¹</td></tr> </table>	Blood	20 dB m ⁻¹	Fat	60 dB m ⁻¹	Soft tissue	70 dB m ⁻¹	Liver	90 dB m ⁻¹	Muscle	180 dB m ⁻¹
Blood	20 dB m ⁻¹										
Fat	60 dB m ⁻¹										
Soft tissue	70 dB m ⁻¹										
Liver	90 dB m ⁻¹										
Muscle	180 dB m ⁻¹										

Half power distance	Another way to think about the above list. It is the depth (mm) at which the sound intensity is halved
	Water 3800 mm
	Blood 150 mm
	Most soft tissue 10-50 mm
	Bone 2 – 7 mm
	Air / Lung under 1 mm

Resolution versus penetration

The attenuation coefficient increases proportionately with frequency. For each MHz of the ultrasound beam there is approximately 1 dB lost per cm traversed. Thus, the higher the frequency, the greater the attenuation and the less the penetration. Resolution and penetration are always a compromise. For the abdomen you might need 3.5 MHz to achieve adequate penetration but, for superficial structures in the neck, you could use 7 MHz as deep penetration not required

Reflection at interfaces

What causes reflection of the ultrasound beam? Ultrasound is reflected at tissue interfaces. The degree of reflection is dependent on the difference between the tissues' acoustic impedance (Z). The latter is a measure of the impedance of ultrasound through a tissue and is the product of the speed of sound and the density of the material.

<p><u>Beef</u> Density = 1.08 Velocity = 0.155 Z = 0.167</p>	<p>Energy reflected: 0.004</p>	<p><u>Water</u> Density = 1.0 Velocity = 0.148 Z = 0.148</p>	<p>Energy reflected: 0.004</p>	<p><u>Water</u> Density = 1.0 Velocity = 0.148 Z = 0.148</p>	<p>Energy reflected: 0.000</p>
<p><u>Water</u> Density = 1.0 Velocity = 0.148 Z = 0.148</p>	<p>Energy transmitted: 0.996</p>	<p><u>Beef</u> Density = 1.08 Velocity = 0.155 Z = 0.167</p>	<p>Energy transmitted: 0.996</p>	<p><u>Water</u> Density = 1.0 Velocity = 0.148 Z = 0.148</p>	<p>Energy transmitted: 1.0</p>

The amount of reflection is not solely determined by the acoustic impedance (Z) of the tissue the US beam meets at the interface, but the mismatch in Z at the interface. Taken from applet at <http://www.ndt-ed.org/EducationResources/CommunityCollege/Ultrasonics/Physics/acousticimpedance.htm>

Resolution

Usually refers to spatial resolution. The minimum separation of close together objects that can be distinguished.

Axial resolution

Resolution of objects separated by depth. Axial resolution is the minimum separation that objects can be distinguished:

Calculation	Wavelength x number of cycles per pulse / 2 Thus, short wavelengths born of high frequencies give best axial resolution.
Lateral resolution	The minimum side-by-side distance between two objects that can be distinguished. Wider the beam width , the worse the lateral resolution. Improved by using high frequency (reduces beam width) and by focusing beam.
Temporal resolution	For an image to appear to move it must be updated about 25 times per second.
Time gain compensation	As we know, with increasing depth the beam becomes attenuated and the image resolution degenerates. Time gain compensation increases the gain of the slower (deeper) signals. Noise will also increase too.
<u>Artefacts</u>	<ol style="list-style-type: none"> 1. <u>Extra images</u>: Reflectors displayed on image that are not really present eg reverberation artefact, mirror image artefact 2. <u>Images in wrong place</u>: Structures that do exist are displayed at erroneous locations eg beam-width, side lobe, propagation spread artefacts 3. <u>Loss/distortion of image</u>: Loss of detail, distortion or structure eg acoustic shadowing
Reverberation artefact	US reflected between two highly reflective surfaces eg between interface and the transducer itself. This leads to the beam travelling twice as far and an image that appears to be twice as deep as it is.
Mirror Image artefact	A type of reverberation artefact. Occurs at highly reflective air/fluid interfaces. First image in correct position but additional image is produced on other side of reflector as well
Side lobe artefacts	Generated at the edge of the beam and project in different direction. May be detected by US transducer if reflector strong enough.
Propagation speed errors	US beam passes through tissues which do not propagate at 1540 m/sec
Acoustic shadowing	Shadow forms on other side of strongly reflecting or profoundly attenuating tissue. eg deep to calcified or prosthetic material
<i>Image modes</i>	
A-mode	The oldest mode and rarely used. The amplitude of the returning echoes from a single narrow beam are displayed as single lines. The amplitude is an indication of the strength of the signal. The horizontal axis is time and therefore also depth. Largely replaced by B-mode. Unlikely you will ever see this mode in action.
B-mode.	Our imaging is always B-mode. It is the standard echocardiography imaging mode for both M-mode and 2-D ultrasound. In B-mode the returning echo is displayed as a dot, its brightness representing the strength off the echo.

Imaging modes

M (movement) mode

A stationary, B-mode beam gives a one dimensional view (akin to a pencil lead) that is repeated continuously. Used to measure cavity sizes in one dimension and to view rapidly moving structures such as valve leaflets. Not used in regional anaesthesia.

2-D

The single beam is made to sweep along a single plane to give the appearance of a moving image. The image is formed one line at a time. These are added together to give a single frame which is repeated to give a real time image.

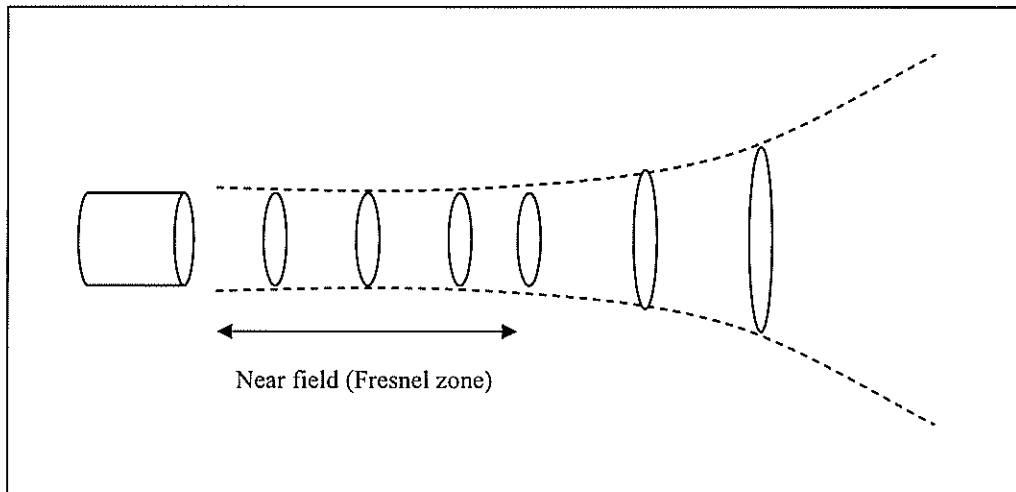

Beam divergence

Although the beam is initially parallel sided (Fresnel zone) it diverges as it moves away from the transducer. This reduces resolution. The Fresnel zone can be increased by increasing the size of the transducer, reducing the wavelength or focussing the beam electronically.

Focussing

Focussing produces convergence and narrowing of the beam and can be achieved by mechanical shaping of the transducer or by phased array of multiple elements.

Transducers

Old devices

Single PZT element that was mechanically steered to produce an arc

Modern 'phased array' devices

Multiple PZT elements on the head of the transducer. The elements are activated sequentially to produce an arc that is rapidly updated to produce a moving image. Phased array activation patterns can be used to electronically focus the beam.

Linear scanner
Curved transducer

Parallel scan lines producing a rectangular image
Arc-shaped scan

Doppler

Doppler effect

Changes in observed frequency when source moves with respect to observer. The change in frequency is proportional to the velocity of the source with respect to the observer.

Measurement of cardiac output using Doppler

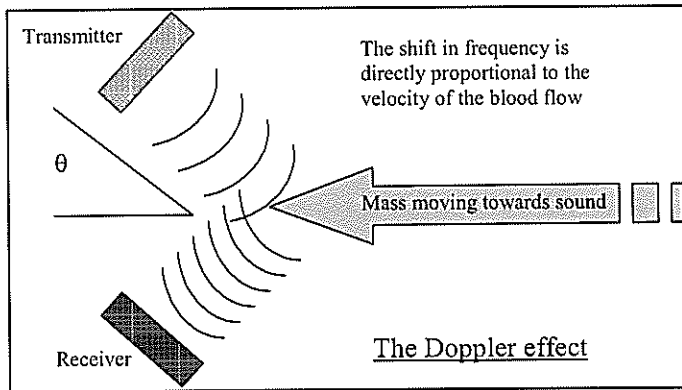

$$V = \frac{C.Fd}{2F_0 \cdot \cos\theta}$$

V = velocity
 C = speed of sound through body tissues
 Fd = frequency shift
 F₀ = frequency of emitted sound
 θ = angle between emitted sound and moving object (45°)

What is required to estimate CO?

- 1) Cross sectional area of ascending aorta (Area A_{Ao}) from 2D -echo or nomogram. (Descending Ao with TOE)
- 2) Ave. velocity of blood flow for each heart beat (V_{avg})
- 3) Time period for ejection during each beat (T_{ej})
- 4) Heart rate

$$CO = Area_{Ao} \cdot V_{avg} \cdot T_{ej} \cdot HR$$

Problem

- Misalignment of beam (angle must be known)
- Accurate cross-sectional aortic root difficult
- Artefact from respiration
- Abnormalities of aorta / aortic valve
- Trauma from probe

Trans-oesophageal doppler

1. US probe in lower oesophagus emits beam at 45° to long axis of aorta to measure velocity in descending aorta. . Continuous visual velocity x time display ensures correct placement. CO calculated by either measuring cross-sectional area aorta by M-mode estimation or estimating the area(A_{AO}) by nomogram. Correction factor incorporated to account for distribution of blood to upper body.
2. Imaging of LV outflow tract and aortic valve area.

'CardioQ' oesophageal doppler

An oesophageal Doppler probe is directed towards the descending aorta. Velocities are measured and an algorithm based on weight and height allows estimation of cardiac output. The manufacturers heavily weight the role of the device in directing fluid therapy in theatre and, in particular, the effect of volume status on the "Flow Time corrected" (FTc). They propose that the width of the base of the Doppler waveform, corrected for heart rate, is shortened when SVR is

increased, the most usual cause of the latter being hypovolaemia.

Suprasternal

Non-invasive measurement of ascending aortic flow. Beam at 0°. Achieving the latter is not always easy and results in inter-observer error

Transtacheal

Doppler probe may be incorporated in ETT

Measurement of cardiac output using 2D-Echocardiography

Basis

Based on Simpson's rule which 'cuts' the ventricle into multiple elliptical discs. If the volume of each disc is estimated, their sum will equal the ventricular volume. In reality, one cross-sectional view is taken, the ejection fraction is noted and the volume is calculated based on a standard bullet-shaped ventricle. Simpson's rule also used in contrast ventriculography.

THE ELECTROCARDIOGRAM

What is electrocardiography?

The cells of the heart generate current which flows outwards through the body (volume conductor). The ECG records, graphically, the potential differences at the skin surface.

Conventions:

Paper speed (usual)
 One small square
 Voltage calibration (usual)
 Current going towards the + ve electrode

25 mm/s
 0.04 s
 10 mm = 1 mV
 Positive deflection

12 lead ECG

Where are leads placed

Limbs: LA, RA and LL plus RL as a "ground" or floating potential
 Chest : 6 leads V1 - V6

Einthoven's triangle

An equilateral triangle drawn parallel to the frontal plain of the volume conductor with the current source, the heart, in the middle.

Importance

Voltage recordings using the corners of the triangle allow the electrical activation of the heart to be "visualised"

3 Standard limb leads

Bipolar limb leads which measure the potential difference between one arm and the other or between one arm and the left leg. In each case, by convention, one limb is connected to the positive terminal of the amplifier and the other to the negative. Current going towards the +ve limb is given a +ve deflection on the ECG.

Placement of limb lead electrodes to form triangle of Standard limb leads I, II and III. Note that the triangle is not truly equilateral but is *scalene*. (*Burger's scalene triangle*). Axis calculations, however, assume an equilateral shape. Arrow represents rough vector of normal cardiac activation.

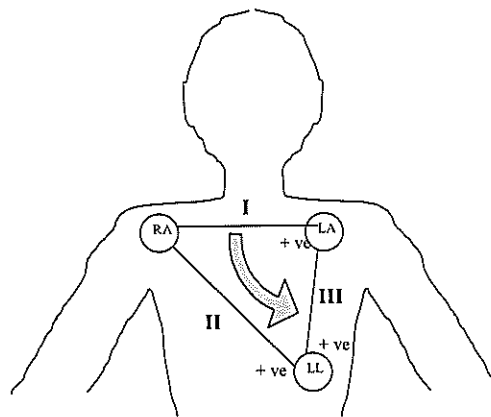

3 Augmented limb leads

Unipolar leads whereby two leads are summed and compared with third (the exploring electrode). Current going towards the exploring electrode is given a positive deflection on the ECG.

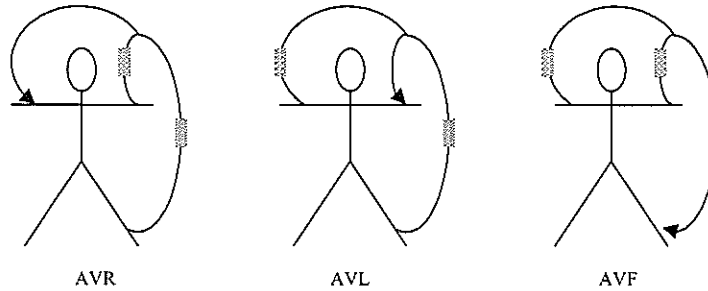

6 Unipolar chest leads -

Unipolar leads. The sum of the potentials at the three corners of Einthoven's triangle is zero (Wilson's central terminal). A reference point can, therefore, be formed at the centre of the heart if the leads are joined together. This is then compared with the exploring electrode which is placed at (usually) six positions on the chest wall. Current going towards the exploring electrode is again given a positive deflection on the ECG.

Chest lead 'axis'

When talking about axis in the chest leads you are talking about the *horizontal* plane as opposed to the *frontal* plane of the limb leads. The horizontal axis is described in terms of rotation, clockwise or anti-clockwise

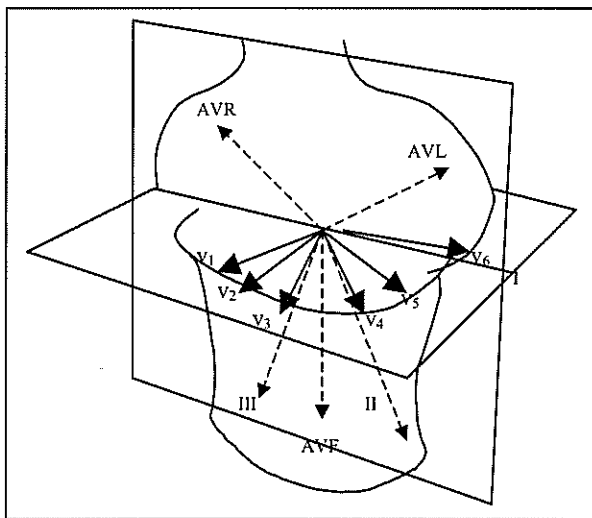

Diagram illustrating the frontal (vertical) plane formed by the limb and augmented limb leads, and the horizontal plane formed from the chest leads

3 Electrode system

RA, LA and LL. Two leads form bipolar leads, the third one is ground. Lead II often used as axis parallels that of heart and P waves show up well.

Advantage

Simple

Disadvantage

Limited view anterior ischaemia

5 Lead system

RA, LA, RL, LL + one precordial lead . Allows the six standard limb leads to be recorded plus one precordial lead (usually V₅).

Modified bipolar standard leads

Placement

RA, LA and LL but placed as per table below.

Advantage

Better indicator of anterior and lateral ischaemia
Better view of P waves

Leads*

Left arm: positive / exploring electrode
Right arm: negative electrode

* The exception to this trend is MCL1 (see table) ** The LL ground is placed where the left arm usually goes

Lead system	MCL 1	CS5	CM5	CB5	CC5
R arm electrode	Ground	R clavicle (-)	Manubrium (-)	R scapula (-)	R ant. axillary line.
L arm electrode	L clavicle (-)	V5 (+)	V5 (+)	V5 (+)	V5 (+)
L leg electrode	V1 (+)	Ground**	Ground	Ground	Ground
Lead selected	III	I	I	I	I
Advantages and indications	Clear P waves and QRS	Anterior ischaemia	Anterior ischaemia and P waves	Anterior ischaemia	Arrhythmias

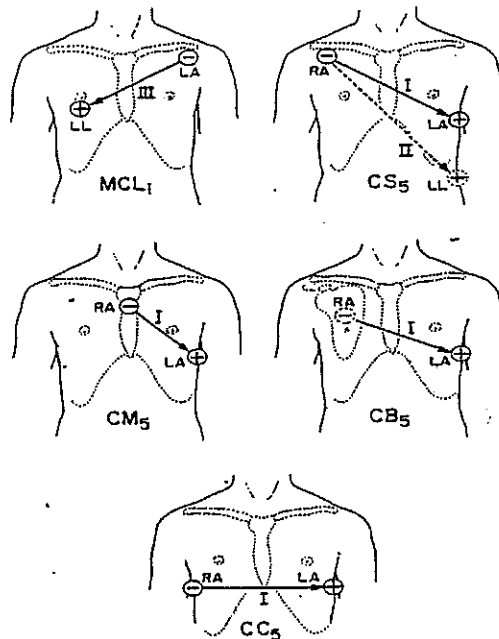

Modified bipolar leads. From Thys D, Kaplan JA. The ECG in Anesthesia and Critical Care. Churchill Livingstone, New York, 1987

Features of the electrocardiogram

P wave

Early part of P -
Mid portion-

RA depolarisation
RA, LA and inter-atrial septum

	Late part of P - LA depolarisation
Axis	Anterior, inferior and leftward - always upright in I and II, inverted in AVR and always upright in V3-V6. Often biphasic in V1 as the early, right atrial activation is directed anteriorly but the later left atrial activation is directed posteriorly.
Normal dimensions	< 3 mm height, < 0.12 s wide
<u>PR interval</u>	Interval between onset of atrial depolarisation and onset of ventricular depolarisation. Activation atria → His → bundle branches → Purkinje
Is SA node to atria interval included?	No
Measurement	Beginning of P to beginning of Q (or R if no Q) Should be measured in lead with widest P and longest QRS
Dimensions	0.12 to 0.20 s
Physiological variation	↑ with age; ↓ with tachycardia
<u>QRS complex</u>	Ventricular depolarisation
Three phases of ventricular activation	1- Septal vector - small anterior and L → R vector 2- Free wall vector - Simultaneous activation of both ventricles from endocardium to epicardium. Because of the large mass of the LV, this vector is large and from R → L 3- Terminal vector - Basal septum and posterobasal region of LV activated last (few Purkinje fibres) - small posteriorly directed vector.

QRS axis in the frontal plane:

Lead	Limbs	Polarity	Axis if vector exactly towards positive / exploring electrode	Axis if vector exactly perpendicular to positive / exploring electrode
Standard Limb leads				
I	RA - LA	LA +ve	0°	± 90°
II	RA - LL	LL +ve	+ 60°	- 30° or +150°
III	LA - LL	LL +ve	+ 120 °	+ 30° or -150 °
Augmented limb leads				
AVR	RA - (LA + LL)	RA + ve*	- 150°	-60° or +120°
AVL	LA - (RA + LL)	LA + ve	- 30°	+60° or -120°
AVF	LL - (RA + LA)	LL + ve	+ 90°	0° or 180°

Table summarising limb lead arrangement and the axis if the ventricular vector is directed directly at each lead

Why is vertical axis determined from Einthoven's hexaxial system inaccurate?

Standard limb leads do not form a strict equilateral triangle. Burger's scalene triangle better.

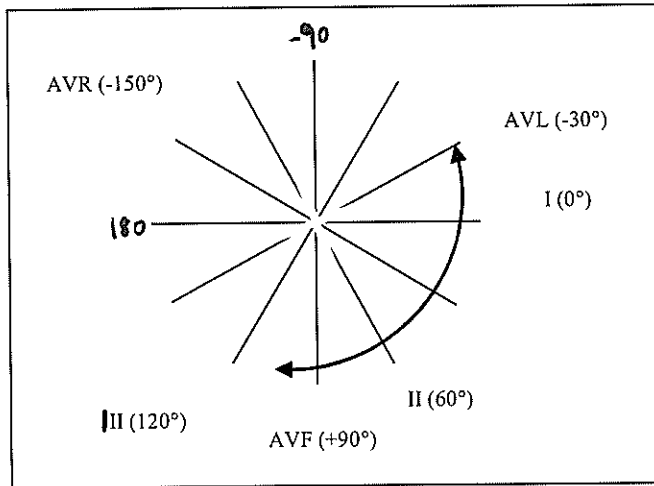

Hexaxial reference system showing:

- I. The value of the vertical axis if the vector is pointing directly towards the indicated leads
- II. The normal range for the frontal plane axis (arrows)

Variation of axis with age

< 40 yrs Seldom < 30° (ie normal 0° - 105°)
 > 40 yrs Seldom > 90° (ie normal -30° - 90°)
 ie axis becomes more left as you get older

Variation with body habitus

Thin - vertical axis
 Fat - more leftward

	Lead I	Lead II	Lead III
The QRS in lead II is equiphase so the axis must be at right angles to this lead and in the direction of the positive lead. Axis must be exactly -30°			
If the axis is further left than -30° (left axis deviation), lead II must now be negative			
The QRS in lead I is equiphase so the axis must be at right angles to this lead and in the direction of the positive leads. Axis must be exactly +90°			
If the axis is further right than 90° (right axis deviation), lead I must now be negative			

A quick method of assessing axis using only leads I, II and III

Note: The estimation of vertical axis can result in variations of up to ± 35°, depending on which method is used.

Horizontal axis (chest leads):

Relevance to amplitude of QRS complex

Initial anterior activation followed by larger posterolateral activation means anterior leads (V1-V4) have an initial small positive deflection followed by a larger negative one (S wave).

The overall R → L vector means predominantly negative deflections in right (V1, V2. ...) chest leads and positive deflections in left (V6, V5, V4 ..) chest leads. Transition is normally between V2 and V4.

Small Q waves in Left chest leads caused by the direction of septal, activation away from the L chest leads.

Counterclockwise rotation

R wave remains dominant beyond V2

Clockwise rotation

R wave does not become dominant until V4 or beyond

Variation of transition zone with age

Moves towards left chest leads (as above)

Duration QRS

< 0.12 s

Normal R wave height

I < 15 mm

AVL < 10 mm

II, III, AVF < 19 mm

V5, V6 < 25 mm (may be greater in young)

Q wave may be absent in V1; QS rare in V2

Physiol. variations in R wave amplitude

↓ with age

Blacks > Whites

Male > female

↓ in obese

Q wave

Negative deflection occurring when the vector of the initial QRS activation is directed away from exploring / positive electrode.

Physiological (*septal*) Q waves

Septal activation when seen from I, II, III, AVL, AVF, left precordial leads.

Age and septal Q waves

Commoner in < 40 yrs

Relationship between transition and septal Q's

Septal Q waves commoner in counter-clockwise rotation because more of the left chest leads will 'see' septal activation as moving away from them

Normal dimension Q

< 0.03 s and less than 25 % height following R as long as it is ≥ 5 mm. Depth in limb leads < 4 mm except in III when it can be 5 mm.

What is the mechanism behind pathological Q waves ?

Infarcted, electrically silent tissue results in a change in the vector of ventricular activation away from the exploring electrode.

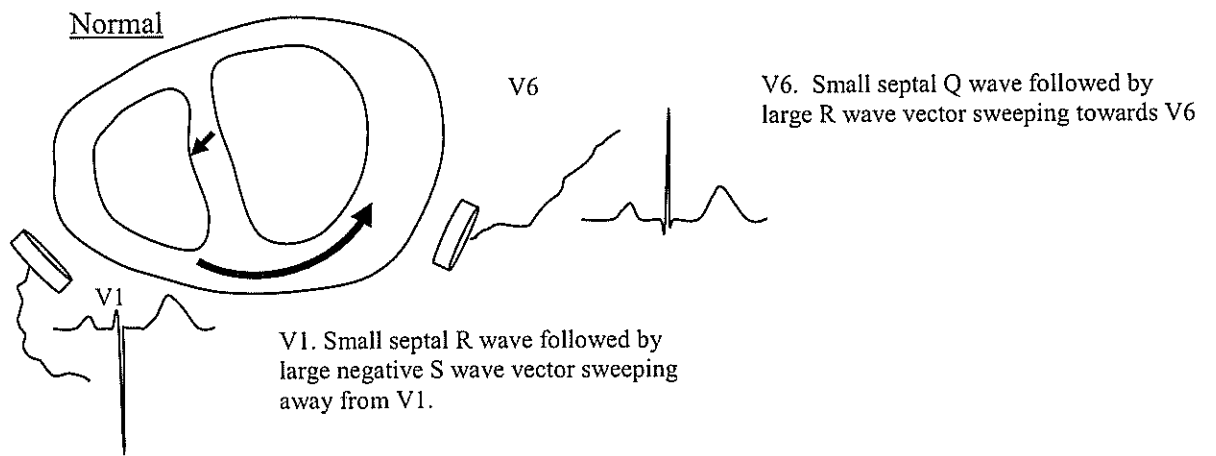

Anteroseptal MI. Anterior, necrotic, non-conducting tissue causes vector of activation to swing away from anterior electrodes causing negative deflections – pathological Q waves.

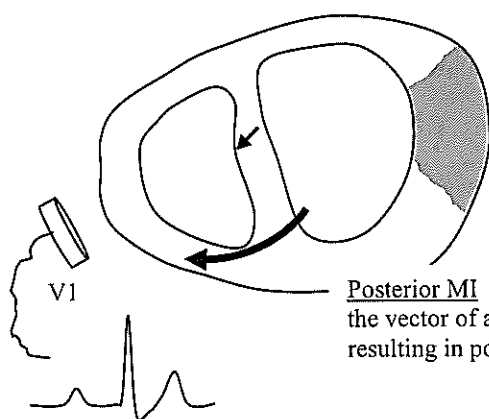
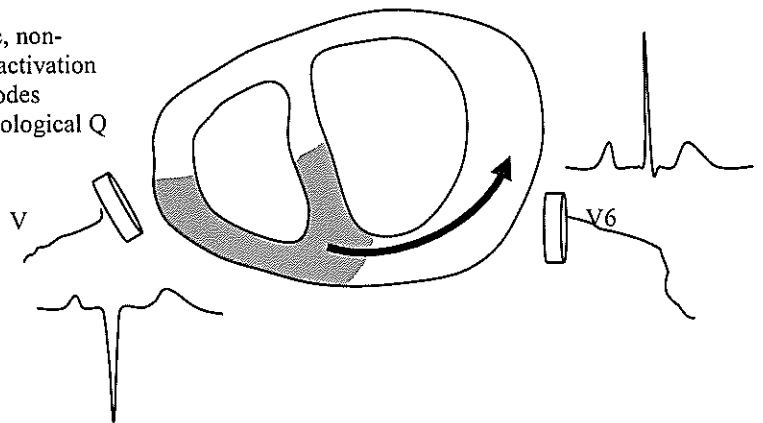

Posterior MI Posterior, necrotic, non-conducting tissue results in the vector of activation swinging towards the anterior electrode resulting in positive deflections - the dominant R waves in V1 ± V2.

<u>ST segment</u>	State of full ventricular polarisation between depolarisation and the start of repolarisation.
Measurement	End of QRS to beginning of T wave. (Strictly speaking the origin of the ST segment is the J point which is the beginning of any change of slope of the T wave. It is often difficult or impossible to determine) Baseline usually taken as the PR segment
Physiological ST elevation	90 % normal subjects in chest leads, particularly V2, V3 (up to 3 mm) Up to 1 mm is common in inferior limb leads.
Physiological ST depression?	Rare: abnormal in any chest leads rare in inferior limb leads
Pathological ST depression	0.1 mV ST depression at 0.06s or 0.08s after the J point.
Pathological ST elevation	Usually taken as at least 0.2 mV ST segment elevation. ST elevation in a lead with a Q wave has particularly low specificity for ischaemia.
Theory of ST segment shift	Ischaemia causes a loss of intracellular potassium →External surface becomes relatively negative charged compared with healthy →Difference in membrane potential between the healthy and injured cells results in a <i>current of injury</i> from healthy to injured →The whole baseline of the ECG becomes depressed → During depolarisation, the external surface of the healthy tissue becomes negative, and the current of injury between healthy and injured cells is abolished. →The baseline, therefore, returns to normal during the ST segment but is seen as apparent ST elevation. (This is the <i>diastolic theory</i> because the current of injury is only flowing in diastole. A systolic theory exists as well)
Direction of ST shift	Depends on direction of current of injury in relation to exploring electrode. Therefore will depend on the position of the electrode, the location of the ischaemia and whether the ischaemia is epicardial, subendocardial or transmural. (Illustration over page)
<u>T wave</u>	Ventricular repolarisation
Explain upright vector	Recovery in general direction of ventricular depolarisation. Reversed polarity is counterbalanced by an epicardium to endocardium direction. So, paradoxically, the first cell to be depolarised are the last to be repolarised.
Persistent juvenile pattern	Normal variant: persistent T inversion in V1 50 % females; persistent T inversion in V2 10 % females persistent T inversion in V3 rarer
Normal dimensions	< 6 mm height (limb leads)

Up to 12 mm (R precordial leads)
Usually asymmetrical (shallower upstroke)

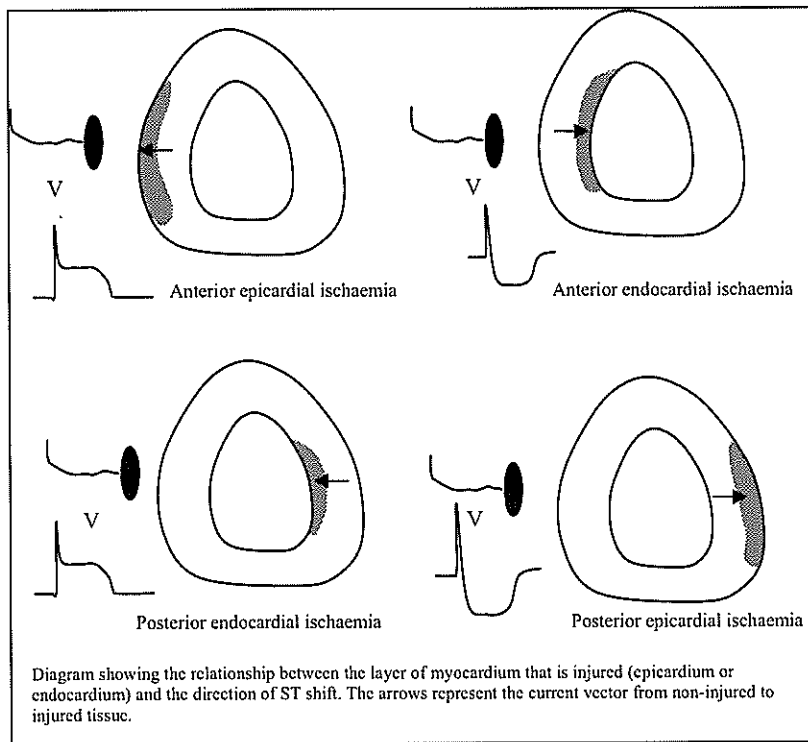

QT interval

Duration of ventricular electrical systole

Measurement
QTc
Normal QTc

Beginning QRS to end of T
Bazett's formula: QT / \sqrt{RR}
male < 0.39 s ; female < 0.41 s
Diurnal variation

U wave

Two theories: Either
a) Repolarisation of Purkinje fibres or
b) After-potentials of ventricular myocardium (low level potentials following incomplete repolarisation of the action potential)

Other normal variants

- RSR' pattern in V₁ (QRS < 0.12s) Found in 2.4% healthy individuals. Attributed to physiological late activation of crista in right ventricular outflow tract. (Note: R', termed R prime, is an upward stroke after the S wave.)
- Early repolarisation syndrome (normal is variant ST –segment elevation) Some degree of ST elevation, mainly in the precordial leads, present in most healthy persons. More pronounced elevation in the normal person is attributed to early repolarisation.

Characteristics: High take-off of ST segment at the J point; Notch or slur on down-stroke of R wave; Concave upwards

- Poor R wave progression in R precordial Small R waves that barely increase in size until beyond V3. Commonest in young women.
- Athlete's heart
 - Bradycardia
 - Sinus pauses of > 2 secs
 - PR prolongation
 - Wenckebach ± junctional escape
 - QRS voltage ↑
 - ST elevation
 - Tall T waves

Artefact

1. Electrode contact problems

a. General contact problems

Motion and changes in skin impedance for whatever reason may cause artefact and baseline wander

b. Electrode potential

At the interface between lead and skin there is metal, gel and skin electrolytes. This active interface generates a potential (*electrode potential*) which is recorded as unwanted ECG interference or baseline drift.

After defibrillation, the potential is often so large that the ECG signal is lost altogether.

Problem is reduced by attempting to minimise the differences between interfaces by using an electrode of silver coated with silver chloride which is, in turn, in contact with a skin-penetrating chloride gel solution.

2. Powerline interference

- Capacitance eg theatre light might induce a 50Hz AC voltage on ECG trace

- Inductance: Magnetic fields produced by transformers induce currents in ECG leads → interference

Screening: In both cases the interfering currents can be drawn away by having the monitoring leads sheathed by a conductive, earthed woven metal.

3. EMG noise

High frequency and random. The latter makes elimination easier by the CMRM amplifier.

4. Electrocautery

Very high frequency.

Minimised by: Use separate power source from ECG
Place reference electrode close to ground pad
High frequency filter

5. Others

Many! Include physical contact with plastic tubing; static charges; infusion pumps; blood warmers; LIMs (see electricity safety)

Common-mode rejection

The ECG amplifier is a differential amplifier in that it only measures the *difference* in the potential between two electrodes. Any signals which are applied equally to both electrodes are eliminated. Common mode

rejection thus helps to eliminate much interference that is applied generally to the patient such as 50 Hz mains interference, EMG etc

Filtering modes

The ECG is a complex sine wave made up of numerous components of different frequencies. For accurate reproduction, all components must be amplified to the same degree and with the same delay. ECG waveforms in the *extremes* of bandwidths are not reproduced as accurately as other component waveforms, resulting in uneven amplification of parts of the ECG and apparent ST depression

Monitoring mode

Bandwidth for *monitoring* purposes: 0.5 - 40 Hz . Narrow bandwidth reduces high and low frequency artefact. However, this may cause artefactual ST depression. This is because the wavelength of the ST segment is ≤ 0.5 Hz and is, therefore, at the lower end of the diagnostic bandwidth..

Diagnostic mode

Bandwidth for *diagnostic* purposes is 0.05 - 100 Hz. Both 'ends' of the bandwidth are extended and thus allow more wave frequencies to be reproduced accurately. Interference from slow artefact (eg respiratory) and high frequency artefact (eg muscle) is increased.

ST analysis mode

AS3 has 3rd band width, *ST filter mode*, (0.05 – 40Hz) which has the extended lower frequency bandwidth required for ST analysis, but continues to filter out high frequency artefact.

PULSE OXIMETRY

Terminology

Functional saturation	Ratio of HbO ₂ : all <i>functional</i> Hb (HbO ₂ + Hb)
Fractional saturation	Ratio of HbO ₂ : all Hb species (HbO ₂ , Hb, HbMet, HbCO, HbSul.)
SaO ₂ % SpO ₂ %	Arterial oxygen saturation Hb saturation as determined by pulse oximeter. Not strictly fractional or functional but in the normal patient near to functional.

Physical principles of light absorption

Lambert Law	Intensity of light transmitted through a solution of known concentration decreases exponentially with the length of path.
Beer's Law	Intensity of light transmitted a known distance through a solution decreases exponentially with the concentration of the solution.

Lambert-Beer's equation

$$I_t = I_o e^{-Ecd}$$

Where:

Io = intensity of incident light (also written as In)
It = intensity light after transmission through the solution
c = concentration solution
d = length of path travelled through solution
E = extinction coefficient (quantifies the tendency for a given solute to absorb light.)

Relevance to pulse oximetry	The Beer –Lambert principles describe the science of light absorption but are not directly used in the estimation of SpO ₂
-----------------------------	---

Key principles of pulse oximetry

What is it?	A device that measures arterial oxygen saturation in the finger by spectro-photometric principles.
Method	i) Light shone at two wavelengths- red (660 nm) - Hb the main absorber infrared (940 nm) - HbO ₂ the main absorber

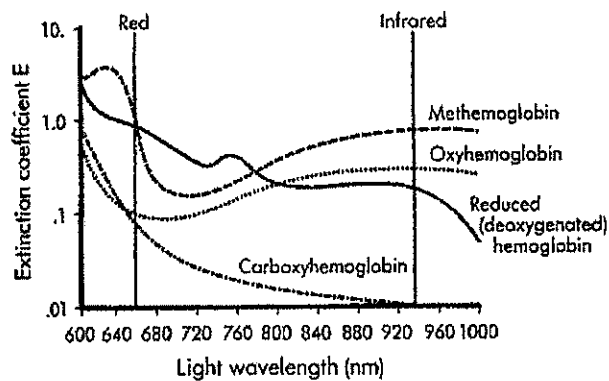

ii) LED's activated sequentially, followed by a period off. Sequence repeated at ~100 Hz.

iii) Intensity of radiation from the two LED's is measured

iv) The absorbance of light from the pulsatile arterial blood (AC component) is distinguished from that of the venous blood and other tissues (DC component) by selecting the pulsatile component only.

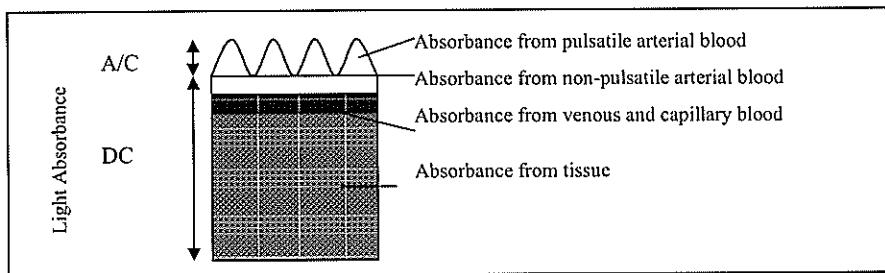

v) The AC component is, however, scaled down first, by dividing by the DC component. This compensates for any variation in the *intensity* of incident light.

vi) The ratio of the amplitude of the red and infrared signals (R) is then calculated, and has a non-linear (but curvi-linear) relationship with SaO₂.

$$R = \frac{a.c.660 / d.c.660}{a.c.940 / d.c.940}$$

vi) Although SaO₂ can be calculated from R, pulse oximeters actually use an empirical calibration curve to relate R to saturation. The curve was determined from normal, fit, healthy volunteers.

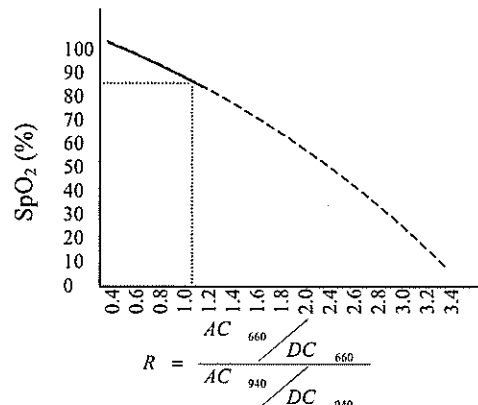

Note: A value of 1 is associated with an SaO₂ of 85%. Most calibration points are between 80 and 100 %. Values below that are extrapolated from the higher readings and are subject to much error.

Two types of pulse oximeter

Transmission (most pulse oximeters) -

Light passes through tissue and is picked up by photodetector on opposite side.

Reflection -

Light source and detector on same side. Can be used on a number of flat surfaces or incorporated into fiberoptic catheters. Neonatal oximeters are often reflectance types. Problems - ↑ scattering - weaker signals, less accurate
Solutions - light sources surround detector or additional, reference, wavelength (805 nm) often used. This is the isobestic point where absorption of light by Hb = HbO₂.

Variations on above :

i) Comparisons may be made between the wavelengths - 660 and -940 nm as above or they are made between the isobestic point and one wavelength - 660 nm and the difference related to SaO₂.

ii) There are several isobestic points. The most useful is around 805 nm (some texts quote 810 or 800 nm).

iii) In two-wavelength machines the wavelengths are usually around 660 nm and 940 nm but other quoted wavelengths include 625 nm (differences in absorbance between Hb and HbO₂ is at its greatest) and 910 nm.

iv) Number of wavelengths used. In advanced pulse oximeters and 'bench' co-oximeters an isobestic wavelength and up to seven wavelengths can be used. Allows CO, met- and sulph- Hb to be measured

v) Frequency of light sequence 100 Hz but also quoted are 30, 500, 720 and 1000 Hz.

Problems / inaccuracies

Accuracy

± 2 % above 70 % saturation
± 3 % between 50 - 70 % saturation.
Most machine very inaccurate below 70%.

Problems

i) Problems with Lambert-Beer law

Wavelength not strictly monochromatic.
Scattering
Solution not homogenous
Length of light path always varying

ii) Delay

Delay in response (may be up to 30 - 60 secs). Due to signal averaging time. The latter is necessary to reduce motion and other artefact.

iii) Patient factors

- Poor peripheral perfusion (vasoconstriction, elderly or patients with PVD.) This reduces the a.c. to d.c ratio (a.c is only 1% of d.c *normally* anyway) and, when the ratio of $R (a.c / d.c) / IR (a.c. / d.c.)$ is calculated, it will approximate unity, and the SaO₂ will read towards 85 %. This is compounded by an automatic increase in gain to compensate for the low signal This amplifies background noise which can be interpreted as pulsation.
- Movement, shivering, Probe malpositioning
- Low saturation (as above)
- Venous engorgement, T.I. - underestimation
- Dyes: Methylene blue (abs. ~ 660 nm) underestimates
Indocyanine green (abs. ~ 660 nm) underestimates
- Bilirubin and foetal Hb? No significant effect.
- Methaemoglobin – approximately same absorption coefficient at 660nm and 940 nm. Thus $R = 1/1$ and oximeter reads it as 85%. Final reading is weighted average of $S_{availableO_2}$ and + 85%.
- Carboxyhaemoglobin - overestimation because HbCO absorbs almost identically to HbO₂ at 660 nm. The pulse oximeter assumes absorption of light at 660 nm is entirely HbO₂ but a proportion will be COHb.
- Nail polish: relatively opaque → underestimation

iv) Environment

High intensity ambient light - especially if a) light flickering at same frequency and b) fluorescent light which emits at ~660nm.

Infrared heaters
Diathermy

Multi-wavelength machines

Rad-57 (Masimo)

This is the first pulse oximeter to be able to measure carbonmonoxide. It emits and processes 8 wavelengths of light

Laboratory co-oximeters

Measures the oxygen carrying state of hemoglobin in a blood specimen. Capable of detecting COHb and MetHb. The SaO₂ noted in a routine blood gas sample is usually an estimate based on oxygen tension and the oxygen dissociation curve. This will not distinguish COHb. It is usually necessary to ask the lab specifically for co-oximetry.

MEASUREMENT OF EXPIRED CO₂

Methods	Infra-red absorption spectrophotometry Photoacoustic spectrometry Laser spectrometry Mass spectrometry Raman scattering Chemical colourimetry Haldane apparatus
---------	---

Infra-red absorption spectrophotometry

Capnography	Device which continuously displays CO ₂ concentration graphically
-------------	--

Principle	Infra-red radiation is absorbed by gas molecules of two or more atoms as long as the atoms are dissimilar. The molecules absorb specific frequencies that are characteristic of their structure and vibration. These absorptions are resonant frequencies
-----------	---

Lambert Law	Intensity of light transmitted through a solution of known concentration decreases exponentially with the length of path.
-------------	---

Beer's Law	Intensity of light transmitted a known distance through a solution decreases exponentially with the concentration of the solution.
------------	--

Lambert-Beer's equation	$I_t = I_0 e^{-Ecd}$
-------------------------	----------------------

where:	I ₀ = intensity of incident light I _t = intensity light after transmission through the solution c = concentration solution d = length of path travelled through solution E = proportionality constant (Ecd = absorbance or optical density)
--------	--

Wavelength at which there is max absorption by CO ₂	4.28 μm
--	---------

Wavelength at which there is max absorption by N ₂ O	4.5 μm
---	--------

Wavelength at which there is max absorption by CO	4.7 μm
---	--------

Components of a simple sidestream capnograph

*** Note: The following has largely been replaced by multi wavelength IR devices that detect and identify volatiles as well as CO₂. See volatile analysis for a schematic diagram.

1. <i>Infrared source</i>	Hot wire or LED (a semiconductor) emitting wide range of wavelengths Light split into two or more beams.
---------------------------	---

2. Chopper wheel

Rotates filters and turns light on and off to prevent slow heating of detector and zero drift

3. Filters

The chopper wheel contains filters that only permit light in two or three specific wavelengths to reach the detector.

4. Sample chamber

Small – decreases time of analysis
Sapphire window as glass absorbs IR

5. Reference chamber

Open to air to allow correction for small variation in IR output

6. Detector unit

i) Thermopile – a mat of tiny thermocouples
ii) Luft type (historical) : Gases in the chambers absorb radiation → heat → ↑ pressure to differing degrees → diaphragm separating chambers moves

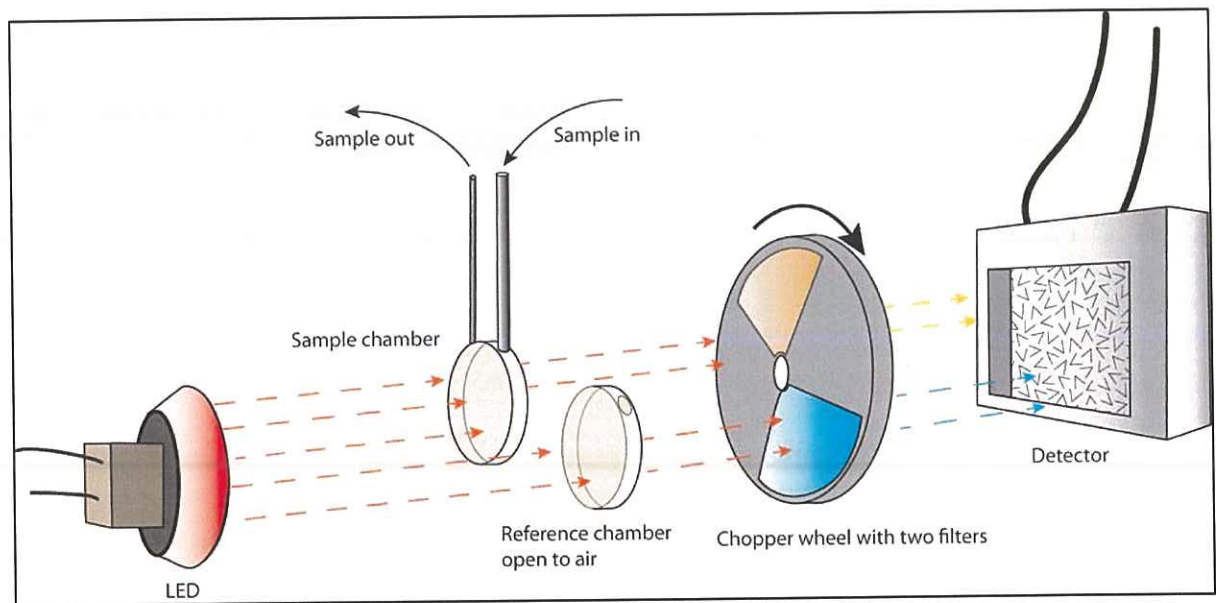

Components of mainstream capnograph

A single IR beam is passed through the sample and then a rotating disc with cells containing a known concentration of CO₂, N₂ (non-absorbent) and a blank disc. The CO₂ concentration is estimated from the ratios of light absorption

Problems

i) Wavelength overlap

Sample containing N₂O and CO₂ may read high

Prevention -

Narrow the IR output using filters
Measure [N₂O] and introduce correction factor

ii) Collision broadening

Presence of other gases (O₂, N₂, N₂O, C₃H₆) widens the spectrum of absorption by CO₂. (↑ by 10% in 50% N₂O). This is because intermolecular forces alter the energy of the molecules and affect their ability to absorb energy.

Prevention -

Measure background gases and add correction factor
Calibrate with the appropriate background gas

- | | |
|---------------------------|---|
| iii) Atmospheric pressure | Recalibration required if change in atmospheric pressure |
| iv) Water vapour | <ul style="list-style-type: none"> i)) Water and secretions absorb IR and may falsely ↑ reading. Samples heated and dried prior to analysis. ii) H₂O 'dilutes' CO₂ in lungs. Usually the sample cell measures at a lower PH₂O (catheters are selectively permeable to water and the sample cell is often at lower temp than body). A correction factor is therefore required to reduce the value if converting the measured PCO₂ to lung PCO₂. iii) Water vapour may condense and block tubing |
| v) Total response time | <p><u>Transit (lag) time</u>: Delay caused by sampling. Minimal in mainstream but several seconds in sidestream.</p> <p><u>Rise time</u>: Delay caused by analysis (Usually <150 ms)</p> |

NB: The term 'response time' is ambiguous. Ward uses it synonymously with rise time. Others (eg Gravenstein; Kenny and Davis,) use it to mean transit time plus rise time. I suggest using the terms 'total response time' = transit time + rise time.

Sidestream sampling

- | | |
|------------------|---|
| Problems | <ul style="list-style-type: none"> Longer lag time of several seconds Loss of FGF 50 - 500 ml/min (important in paediatrics, low flow) FGF loss has to be returned to circuit Obstruction to sampling tube Blockage by water condensation ∴ water trap Leaks Disposable parts → cost |
| Main advantages: | <ul style="list-style-type: none"> Convenient and light interface Remote monitoring easier Cheap interface No ↑ VD Hygiene better Multiple gas capability |

Mainstream sampling

- | | |
|------------------|---|
| Problems: | <ul style="list-style-type: none"> Adds bulk to circuit Disconnections Increased dead space Detector expensive and easily damaged Single agent capability May injure patients, burns, less hygienic |
| Main advantages: | <ul style="list-style-type: none"> Fast because of shorter lag time (≤ 100 ms) No loss of FGF Extra scavenging not required Less interference from water No reference cell required |

v) PET CO₂ may be very different from Pa CO₂

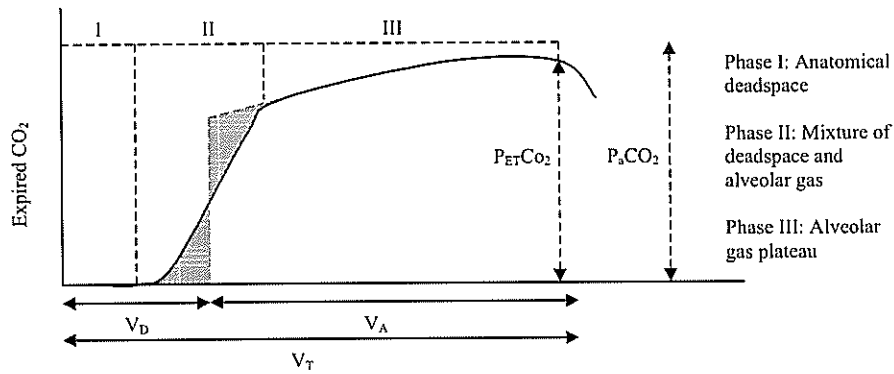

Uses for capnography

- Breathing system function
- Detection of oesophageal intubation
- Detection of disconnection
- Control of CO₂ during IPPV eg elective hyperventilation
- Detection of embolism
- Weaning
- Criteria for brain death
- Detection of hypermetabolism
- Information from capnograph pattern
 - onset spontaneous respiration
 - airways obstruction etc

pH chemical colourimetry

" Nellcor Easy Cap "

pH indicator impregnated into paper

Haldane apparatus

What is it?

A historical method of measuring CO₂ in gas mixtures by measuring the reduction in volume after CO₂ is absorbed by potassium hydroxide.

Others

- Mass spectrometry
- Laser analysers
- Photoacoustic spectrometry
- Raman scattering

See vapour analysis

OXYGEN ANALYSIS

Oxygen analysis	
Oxygen tension	Paramagnetic analysis (G) O ₂ electrode (Clark, polarographic electrode)(B & G) Fuel cell (G) Ultrasound (G) Raman scattering (G) Ultraviolet (G) Mass spectrometry (G) Magnetic acoustic spectrometry (G) Gas chromatography (B &G)
Oxygen saturation	Pulse oximetry Co-oximetry
Oxygen content	Calculation from saturation Van Slyke apparatus Lex O ₂ Con

Oxygen tension

Paramagnetic (Pauling) analyser

Definition of paramagnetic substance	A substance which, when directed into a magnetic field, locates itself in the strongest part of the field. eg O ₂ , NO.
Diamagnetic substances	Repelled from field eg N ₂ O, N ₂ , CO ₂
Why does it happen?	The spin of electrons around the nucleus leads to a magnetic 'moment' in the outer shell of the molecules. With paired electrons, the magnetic effects cancel each other out. With unpaired electrons, as in O ₂ , the magnetic field attracts an external magnetic field..
Main type in use today	Differential pressure transducer . By far the most common type.
Other versions	Dumbell on filament (no longer in common use) Null displacement (no longer in common use) Magneto-acoustic spectroscopy (not in anaesthesia)
i) Differential pressure transducer	eg in Datex Multicap / Capnomac / AS3
Principle	Sample containing oxygen sucked through a magnetic field causes a pressure difference with reference gas across a transducer

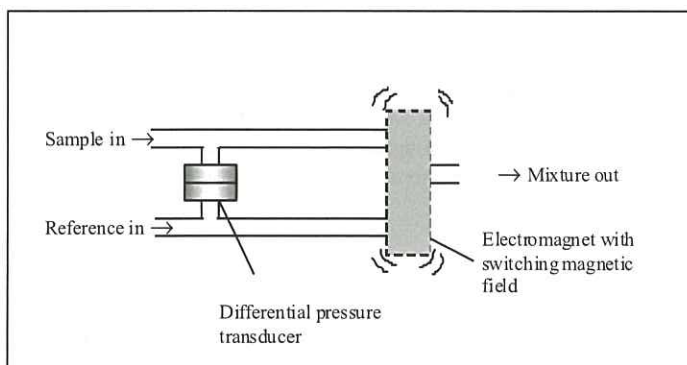

Reference gas and sample gas are sucked through the analyser. Paths join at exit and at differential pressure transducer where they are separated by a diaphragm. The magnet is switching on and off at about 110 Hz. Oxygen is attracted into the magnetic field, transiently reducing the pressure in that

limb. If there is more oxygen on one side (usually the sample limb) the diaphragm of the transducer deflects to that side. The rapid fluctuations in pressure difference between the limbs could be thought of as a vibration that gets louder, the greater the $[O_2]$ difference between the limbs. The difference is converted to a DC voltage that is proportional to the O_2 tension in the sample limb.

Advantage	Linear Less affected by vibration Fast response: 150ms
Issues	H_2O biases reading so gas must be dry Temperature must be kept constant Reference sample returned to circuit → dilution circuit gases Regular calibration required Nitric oxide theoretically could cause over-reading of oxygen tension but unlikely with therapeutic concentrations (< 40 ppm)
ii) Dumbbell on filament (no longer used)	O_2 attracted into non-uniform magnetic field due to its unpaired electrons. Displaces nitrogen filled dumbbells on filament Mirror on dumbbell swivels and reflected light beam moves on scale No longer used in anaesthetic monitors
iii) Null deflection type (no longer used)	Similar to above but reflected light, detected by photocell causes current to flow in coil around dumbbell and stabilise the mirror in the resting position. Current required measured. More accurate than dumbbell version but no longer used in anaesthetic monitors.

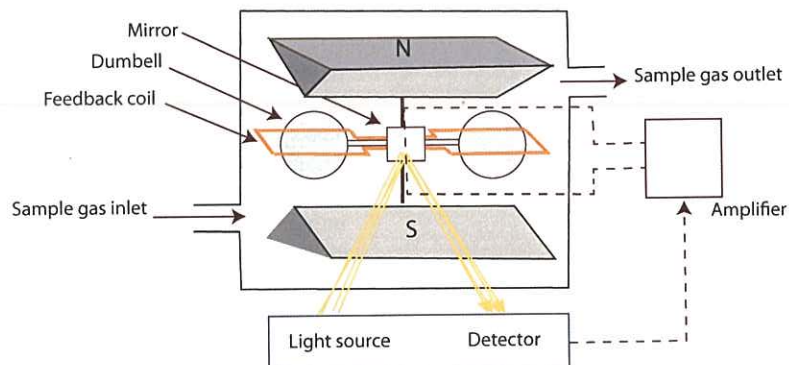

Null-deflection paramagnetic analyser

Problems	Delicate, affected by vibration Water vapour affects readings Accuracy limited in simple dumbbell method but null deflection type very accurate ($\pm 0.1\%$) Need to calibrate for diamagnetic background gases N_2 , N_2O
iv) Magnetoacoustic spectroscopy	Similar to above. The test and reference samples are subjected to an alternating electromagnetic field. The compression and expansion of the gas results in an audio signal, the magnitude of which is proportional to the concentration of oxygen in the mixture.

Electrochemical cells – general notes

Types of electrochemical cells

Oxidation – reduction reactions (redox reactions) take place in electrochemical cells. There are two types:
Electrolytic cells in which the reactions are non-spontaneous and require a supply of electrical energy in the form of a polarising voltage
Galvanic cells where the reaction is spontaneous with the polarising voltage supplied by carefully selected dissimilar metals

Electrodes and charge

In the spontaneous reaction of a galvanic cell, the metal of the anode (lead) oxidises easily. The electrons produced here mean the electrode is negatively charged. The electrons move round through the external circuit to the inert cathode and reduce the aqueous O_2 . In both types of O_2 electrochemical cells, the cathode metals are inert and are simply a 'launching' pad for the electrons. The anode of an electrolytic cell is positive since the applied current moves electrons from the anode while at the same time attracting anions from the solution. In both cells oxidation (of the metal) takes place at the anode and reduction of Oxygen at the cathode.

Fuel cell

(Microfuel cell, Galvanic cell)

Principle

A spontaneous redox reaction. Spontaneous oxidation of a lead anode delivers electrons to an inert gold cathode. The electrons at the cathode reduce oxygen that has diffused into the cell. The more oxygen presenting at the cathode, the more electrons are able to leave the cathode and the greater the current produced. The current is directly proportional to the concentration of oxygen at the cathode.

Battery required?

No, the redox reaction in a Galvanic cell is 'spontaneous'. Lead 'loves' losing electrons: it is readily oxidised. The cell becomes exhausted as $Pb \rightarrow PbO$.

What determines speed of exhaustion?

Duration of use and O_2 concentration

Accuracy

$\pm 6\%$

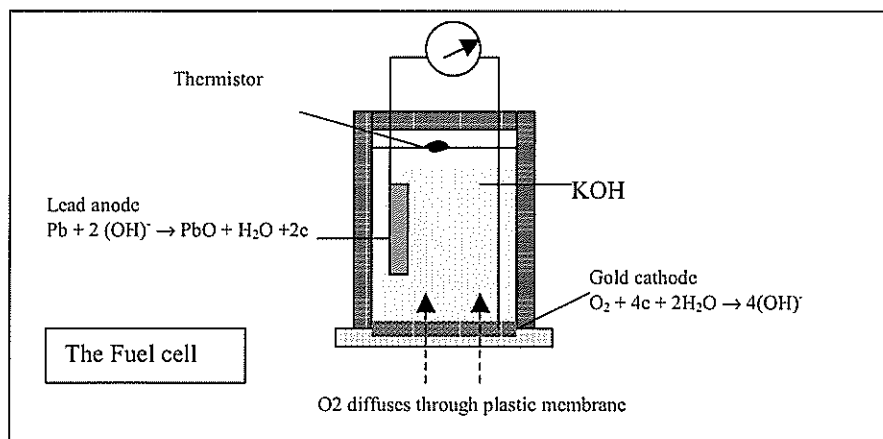

Problems

Temperature compensation required. Contains thermistor
 Humidity - no effect on accuracy
 $N_2O \rightarrow N_2 + H_2O \rightarrow \uparrow$ damage from pressure in cell

Slow ~ 30 sec. 'Breath to breath' not usually possible but newer, faster devices may make this possible
 Cell exhaustion (lead anode gradually consumed)

Oxygen electrode
 (Polarographic, Clark)

Principle

The redox reaction in this cell is non-spontaneous and electrical energy is required to induce electrolysis. A voltage of 0.6 V is applied to provide the necessary potential for reducing O₂ at the cathode. The more O₂ available at platinum cathode, the more electrons taken up at the cathode and the greater the current flow. To complete the electrical circuit it is necessary to have an oxidation reaction at the anode to release electrons:

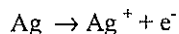

Current flow is linear and proportional to oxygen concentration.

Accuracy - ± 10%

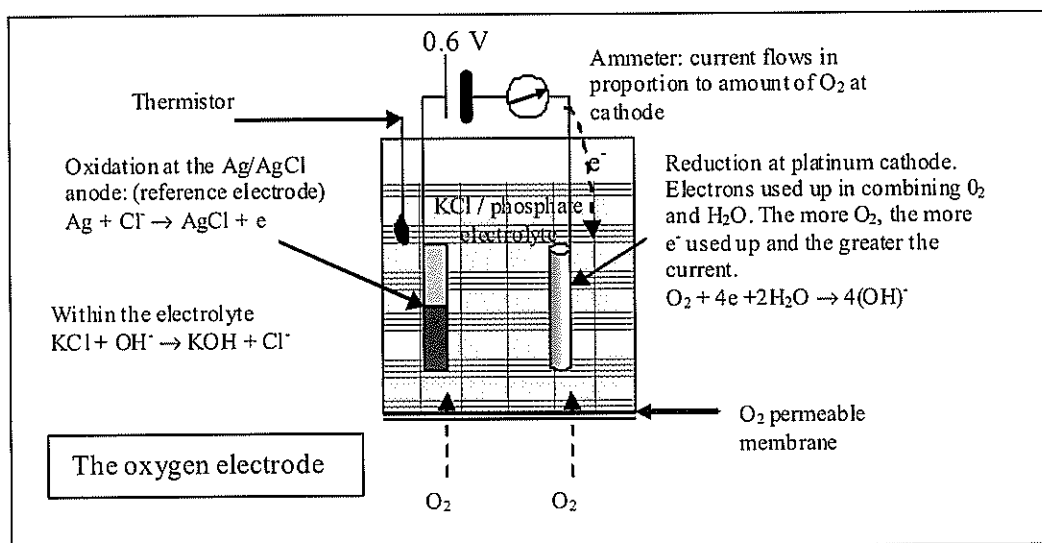

Why 0.6 V?

At around this potential, the current resulting is proportional to the oxygen tension at the cathode. Different texts describe polarising voltages of between 0.5 and 0.8 V

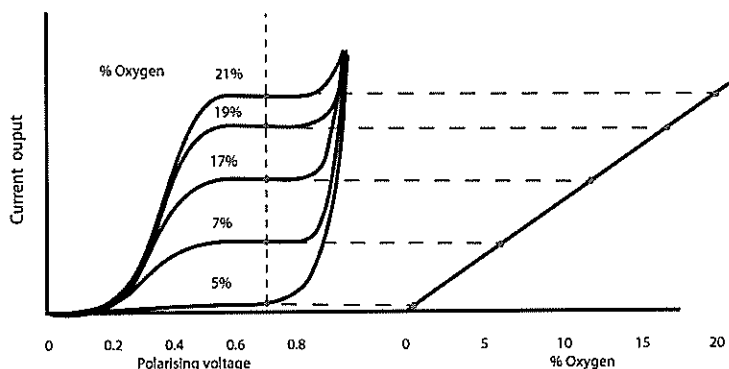

At a polarising voltage of 0.7 V the current output is proportional to the oxygen concentration

Applications	In vitro Intravascular Transcutaneous Breathing systems.
Advantage over fuel cell	Faster than fuel cell but still relatively slow and does not permit breath-to-breath analysis. Lasts longer (assuming battery replaced)
Problems	Temperature must be kept constant (37 °C) Humidity - no effect on accuracy. Halothane may interfere- membrane impermeable to halothane Electrode must be kept clean from protein deposits; (platinum electrode covered in plastic membrane) Battery required and may run flat Maintenance, repeated calibration required Slow response time ~10-20 secs (faster than fuel cell). But 'breath to breath' not possible
Transcutaneous	Skin heated → vasodilatation → O ₂ diffuses through skin → through polypropylene membrane into electrolyte → reaction as above. Increase in metabolism from warming offset by a reduction in O ₂ solubility as well as a shift in the ODC to right. (Radiometer TCM4)

Summary table: Fuel cell vs Oxygen electrode		
	Fuel cell	Oxygen electrode.
Other names	Galvanic cell analyser	Polarographic electrode, Clark electrode
Battery required?	No (except for alarm)	Yes
Anode	Lead	Silver / Silver chloride
Cathode	Gold	Platinum
Electrolyte	KOH	Phosphate buffer with KCl

Ultrasonic

eg GEM 9100 (CIG Healthcare) anaesthetics machine

Principle

Velocity of sound varies with the concentration of gas it travels through. Ultrasonic transducer emits a signal which is reflected and picked up. The delay in pick-up varies with the oxygen concentration. Gas sample must be a binary mixture of known gases.

Fluorescence

The fluorescent light from certain dyes can be quenched by oxygen. This dye is incorporated in fiberoptic catheters and is excited by light at 385 nm producing an emitted light at 515 nm. The decrease in light emitted is directly proportional to the oxygen tension. 'CDI system 1000'

Others:

- Raman scattering
- Ultraviolet
- Mass spectrometry
- Gas chromatography

See vapour analysis chapter

Oxygen content

Calculation from saturation

$$\text{O}_2 \text{ content} = \text{SaO}_2 \times [\text{Hb}] \times \text{Hufner constant} + (0.003 \times \text{PO}_2)$$

Van Slyke apparatus

Blood haemolysed by lactic acid →
Gases extracted →
O₂ absorbed by alkaline pyrogallol →
Fall in volume or pressure of blood sample measured.

Problems

Large sample
Difficult and time consuming.

Lex O₂ Con

Principle

Carrier gas (oxygen removed by catalyst) →
Sample introduced and haemolysed by distilled water
O₂ enters carrier gas bubbles and is transported to fuel cell
Reaction at cathode: $\text{O}_2 + 4\text{e} + \text{H}_2\text{O} \rightarrow 4(\text{OH}^-)$
Current produced by electrons is proportional to total number of O₂ molecules.

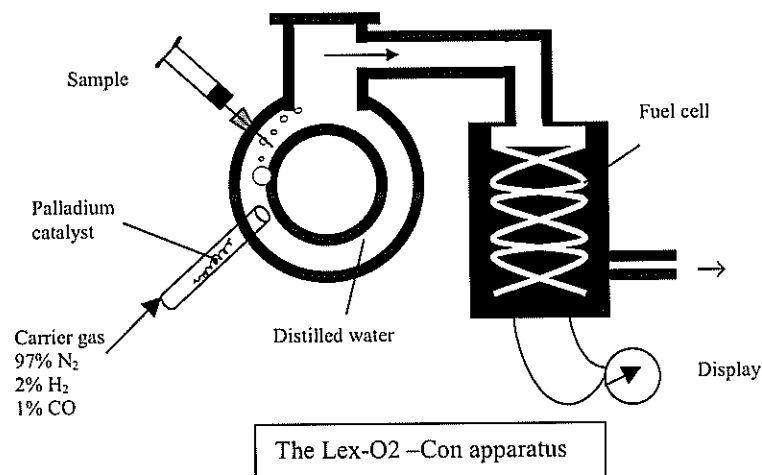

ANAESTHETIC VAPOUR ANALYSIS

Vapour analysis	
Light absorption Raman scattering Mass spectrometry Piezoelectric crystal resonance Thermal conductivity (Katharometer) Electromagnetic radiation emission Solubility Density Interferometry / refractometry Ultrasound Gas chromatography	Infra-red Photoacoustic spectrometry Ultraviolet Laser

Infrared agent analysers

eg Datex monitors. Most commonly used method..

Principle	. Infra-red radiation is absorbed by gas molecules of two or more atoms as long as the atoms are dissimilar.
Lambert – Beer laws	See capnography
General principle of analyser	See capnography
Multi wavelength (non-dispersive)	Modern anaesthetic IR agent analysers combine CO ₂ and volatile analysis in a multi-wavelength device as illustrated. Multiple wavelengths are transmitted (eg 7 wavelengths are mentioned in the Datex manual) which are specific for different agents. Thermopile detectors measure the transmitted energy for each wavelength.
Single wavelength devices	A single wavelength filter is added to the chopper wheel illustrated in Capnography section. (Texts quote different wavelengths: 3.9µm or 3.3 µm or 10 - 13µm). The user then manually changes the module to the required volatile to be measured. An algorithm adjusts calibration for that volatile. Largely been supplanted by multiwavelength devices.
Dispersive	A whole IR wavelength range is transmitted and the absorption spectrum measured by a Fourier transform instrument.
Problems	As for IR analysis of CO ₂ . See capnography.

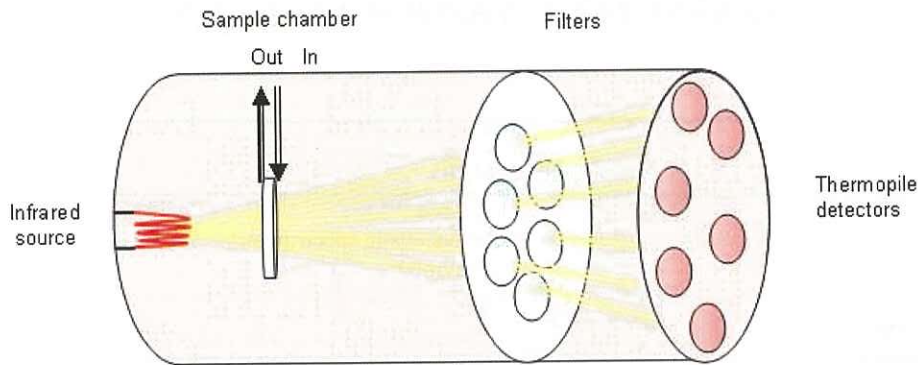

Non-dispersive infra-red analyser measuring absorption of gas sample at seven different wavelengths

Ultraviolet

(eg Penlon Halothane meter)

(250 – 400 nm). All atoms absorb UV light so, theoretically, could be used for many gases. Used for gases that don't absorb in the infrared region of the spectrum such as nitrogen, oxygen and hydrogen and halothane analysis. In other respects similar principle to an IR device.

Problem

Decomposition of halothane to bromide and HCL so can't be returned to circuit.

Photoacoustic spectrometry

IR light is chopped by chopper wheel into three beams and pulsed at three different frequencies into sample chamber. Before entering the chamber, the beams are passed through three narrow band filters so that each will target a specific gas (N₂O 3.9µm, CO₂ 4.3µm, anaesthetic agents 10.3 -13 µm) The gas sample expands and contracts to a degree dependent on the amount of absorption of IR by the three gases and, therefore, the concentration of the gases. The resulting pressure waveform is detected and amplified by a microphone. The individual gases are selected by "listening" to the particular pulsed frequency which was assigned to the specific gas. The amplitude ("loudness") of the pressure waveform at that pulsed frequency is related to the concentration of that particular gas. Agent identification not possible.

Raman scattering

Principle

Raman scattering occurs when light passing through a gas is partially absorbed by the molecules and then re-emitted with different intensity and frequency. This is termed inelastic scattering. The shift in frequency is specific to an individual gas and the change in intensity is related to the number of molecules. It is a minute part of scattering involving ~ 1 in 10^7 photons..

Principle of gas analyser

Intense monochromatic light (He-Ne laser) is shone through a sample and the scattered light is measured at right angles to the source. Frequency and intensity shifts permit identification and concentration measurement respectively.

Detectors are at right angles to the beam so as not to be swamped by the majority of incident radiation

Commercially available device

Ohmeda "Rascal" anaesthetic gas monitor

How is the majority of light scattered?

Rayleigh scattering (elastic scattering), where re-emission occurs without energy loss or frequency shift.

Advantages

Rapid (100 ms), breath-by-breath analysis possible
Accurate
Gas unaltered
H₂O does not interfere
Multiple gas capability
Portable

Which gases cannot be measured?

Molecule must be symmetrical so mono-atomic gases such as He, Ar, Xe cannot be measured.

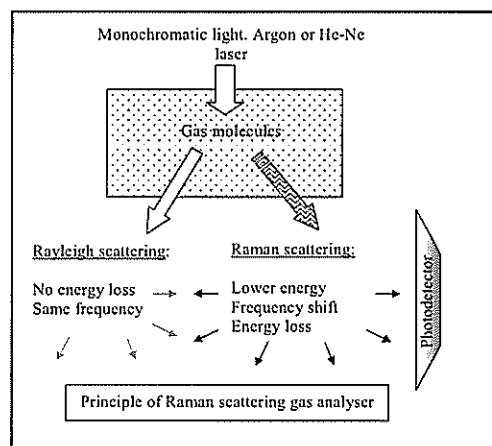

Laser analysers

Intensity of helium-argon light measured after absorption by CO₂. Very fast. Also used for detection of alcohol

Mass spectrometry

What is it?

A gas analyser that separates the components of a gas mixture according to their mass to charge ratio.

Principle

1. Ionization

A tiny portion of the sample is passed through an ionizing beam of electrons. The electron beam knocks electrons off the sample causing the sample molecules to become positively charged ions (usually 1⁺). As ions are relatively unstable there will also be break down of the parent molecule into additional smaller ion fragments.

2. Acceleration.

The ions are accelerated forwards

3. Deflection

The ion stream passes through a magnetic field. The ions are deflected according to their mass/charge ratio. As most of the molecules have the same charge (1⁺), it is their mass that determines the deflection. Smaller masses have more deflection

4. Detection

The positively charged ions hit a metal plate and attract electrons. This creates a current towards the area of impingement. The greater the amount of ion, the greater the current flow and the larger the peak displayed.

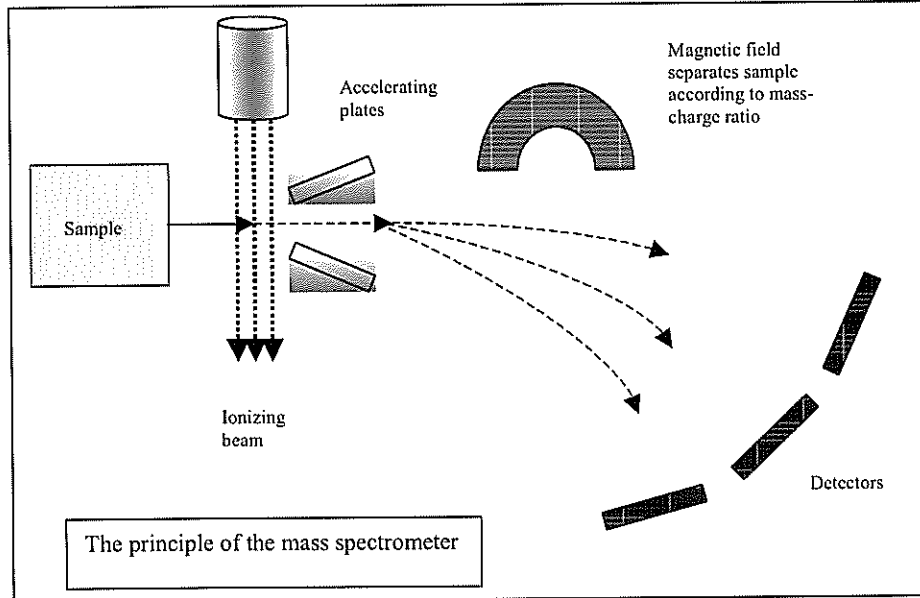

Fragmentation pattern

The original molecule produces a characteristic fragmentation pattern that is used to identify the molecule and differentiate it from other molecules of the same MW. Eg CO_2 and N_2O

Problems

- a) Identifies fractional composition of a sample, not the partial pressures.
- b) Identifies only the molecules it has been set for.
- c) bulky
- d) ionised gases must be discarded

Advantage

- a) rapid response
- b) one machine for multiple sites

What is a quadrupole mass filter?

Similar to above but the ionised beam is passed through a quadrupole mass filter which has four rods with an electrical charge alternating at radiofrequency rates. By altering the frequency some ions can be allowed to pass through the filter to the detector at the other end, while the others undergo increasing oscillation, hit the rods and lose their charge. Smaller and lighter than magnetic version.

Piezoelectric crystal resonance

eg Engstrom Emma.

What is the piezoelectric effect?

If an electric potential is applied across a crystal it causes it to contract at a specific frequency.

Principle

Quartz crystal coated with silicone oil. Absorbance of anaesthetic agent by the oil will increase the crystal mass and

change its resonant frequency when a current is applied. Frequency compared with uncoated crystal.

Thermal conductivity/ katharometers

Gases with high thermal conductivity conduct heat more readily than ones with low thermal conductivity. Gas passed over heated wire. Degree of cooling of wire and, therefore, its electrical resistance depends on the gas' thermal conductivity as well as the temperature and flow of gas. (If applied to gas analysis, the gas mixture must be a binary mixture of two known gases)

Main use

Helium concentrations; Xe possible
CO₂
Detector in gas-liquid chromatography

Emission of electromagnetic radiation (gas discharge tube)

Nitrogen meter only commercially available device. Used in single breath nitrogen washout tests. Gas is drawn between two ionizing electrodes. Gas glows purple, the wavelengths of the emitted radiation being characteristic of the gas. Detector is photoelectric cell. Specific and rapid.

Solubility

(Drager "Narkotest")

Rubber strips attached to a pointer elongate as they absorb vapour. Designed for Halothane but suitable for several vapours.

Density (Waller chloroform balance)

Historical. Glass bulb filled with air balanced by a small weight in a chamber. If a more dense gas than air is introduced into chamber the bulb will rise. The apparent weight reduction is related to the density of gas introduced.

Ultrasound

Estimates the relative concentrations of gases in a binary mixture from the speed of sound in a gas sample if the two gases have different densities, and therefore different speeds of sound. Has been validated for Xe measurement.

Interferometer / Refractometer

This is a commonly used method to check the calibration of vaporisers and utilises the principle that the velocity of light through a gas is dependant on the number of gas molecules present.

Refractive index of substance A =

Velocity of light through vacuum
Velocity of light through substance A

Determinants of denominator

Number of molecules of gas A present and, therefore, also temperature and pressure of gas A.

What is an interference fringe?

When two beams of light from the same source are focussed onto a screen and allowed to overlap, they form a series of light and dark fringes. The bright fringes occur when the two beams are in phase ie when they have traversed a path of the same length, or when their paths differ by a whole number of wavelengths. The dark bands occur when the path lengths differ by a half-integral number of wavelengths (ie the beams are out of phase by 180°)

Riken refractometer (portable)

Light is split into two beams. One passes through the analysis chamber and one through the reference chamber (vacuum or air, usually). Zero is "set" initially by noting the interference pattern when background gas is in *both* chambers. The gas to be analysed is then aspirated into the analysis chamber. The velocity of the beam of light passing through this chamber is reduced and this results in a shift in the fringe pattern to a degree that is related to the concentration of the gas. Figure (b). The concentration can be read directly from a previously calibrated scale.

Rayleigh refractometer

Large, ? non-portable version

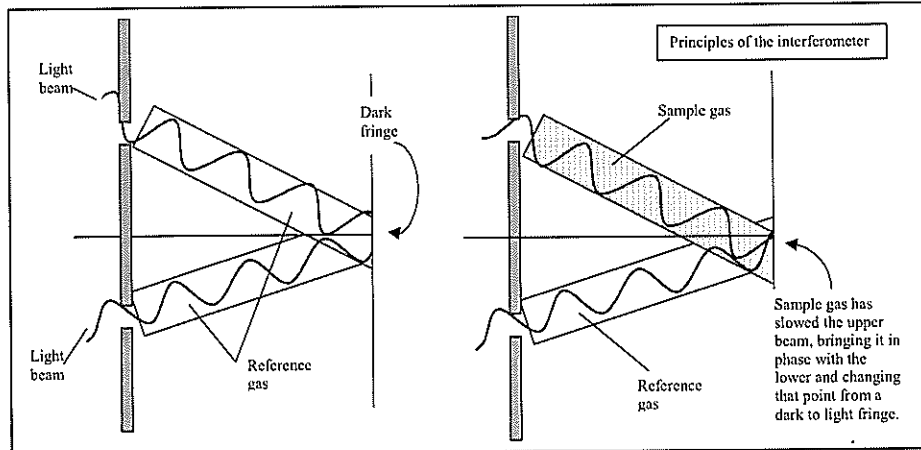

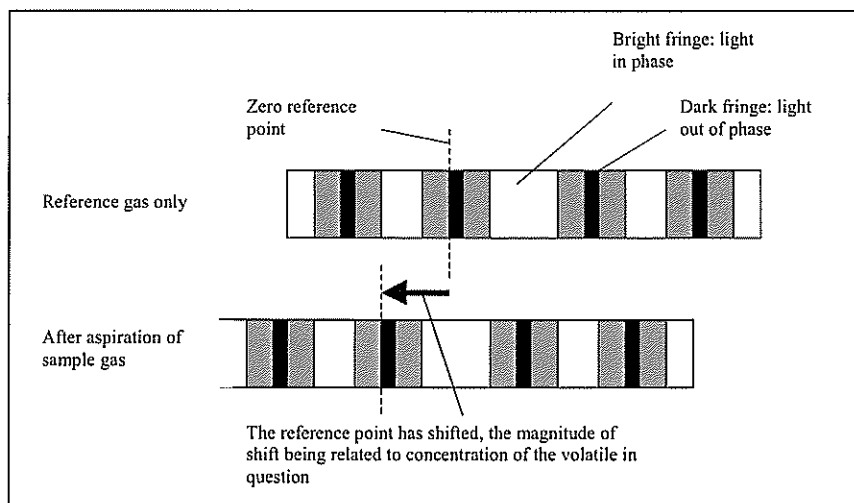

Gas-liquid chromatography

Principle

Molecules of solute partition between two solvents, the degree depending on the balance of attractive and repulsive forces between the solute and solvent.

Details

One solvent absorbed onto stationary phase (eg silicone oil on silica-alumina)
 One solvent is carrier gas (He, N₂ or Argon) flowing through stationary column.
 Mixture to be analysed introduced into stream. Low soluble, highly volatile components appear first at outlet. Highly soluble components appear last.

How are the components detected?

Katharometry: Thermal conductivity

Flame ionization: H₂ and O₂ are added to the organic (usually) gas mixture. Organic compounds are ionized by ignition and, when a polarizing voltage is applied across the flame, a current flows between capacitor plates. The more organic compound, the greater the current.

Electron capture: Halogenated compounds are bombarded with gamma rays. Electrons are given off by the halogen ions in relation to the amount of the substance.

NB:

- system must be kept at a constant temperature
- detectors cannot absolutely identify agents
- this is not a continuous sampling device and is not suitable as an anaesthesia monitor. May be used for measuring atmospheric anaesthetic concentrations

LABORATORY MEASUREMENT OF pH AND CO₂

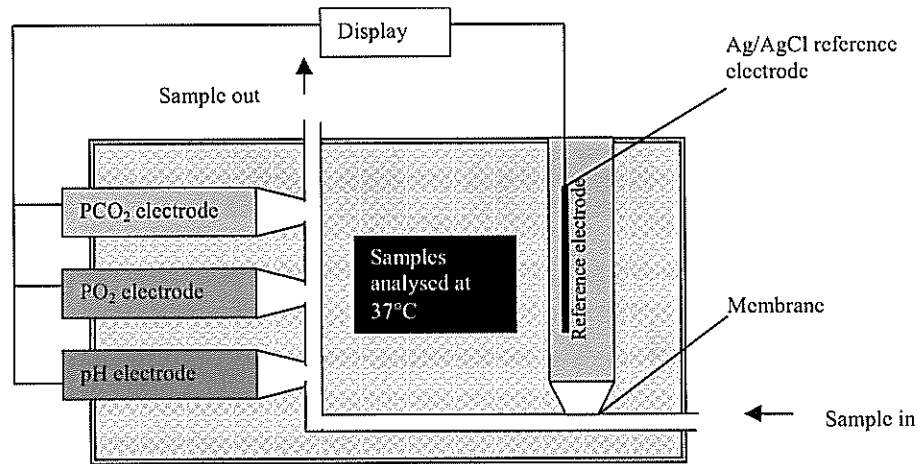

Schematic diagram of blood gas analyser based on Parbrook. (NB. The pH reference electrode is often Hg/HgCl and the CO₂ electrode usually has its own reference electrode incorporated in its housing).

Measurement of pH

Indicator dyes - pH paper, spectrophotometer
pH electrode
Ion-sensitive field effect transistor

pH electrode

Define pH

pH is a dimensionless measure of the acidity or alkalinity of a solution. Aqueous solutions at 25°C with a pH less than seven are considered acidic, while those with a pH greater than seven are considered basic (alkaline). pH is dependent on H⁺ activity which is largely dependent on the hydrogen proton (H⁺) concentration and temperature. In a neutral solution with a pH of 7 there are 10 million (10⁷) times fewer hydrogen ions than there would be in solution with pH 1. The pH scale is, thus, an inverse logarithmic representation of [H⁺].

Principle behind pH electrode

Potentiometry, with similar principles to a battery.

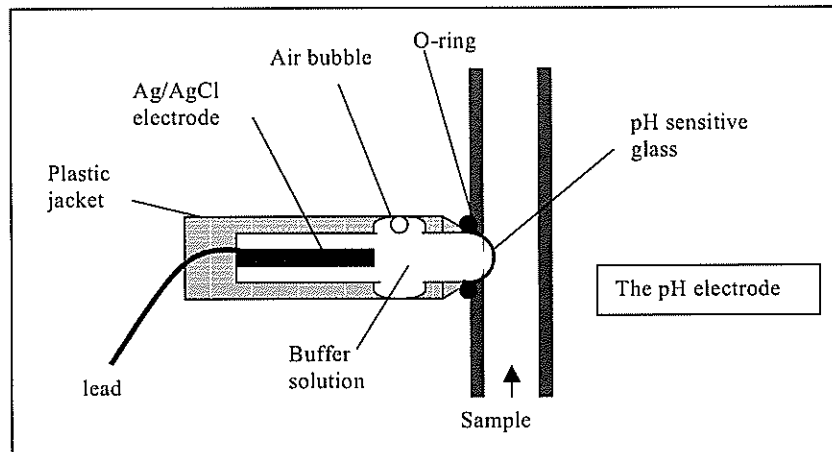

Potentiometry.

If a metal is placed in a solution of one of its' salts (eg Ag and AgCl) there is a tendency for metal ions to go into solution, leaving the metal with a negative charge. This creates an EMF and is called a half-cell.

If there are two dissimilar half cells separated by a porous partition, an electromotive force EMF is set up between them and current will flow. If ion concentrations at the half cells are accurately maintained using saturated solutions, all the EMF's are constant.

How does the pH electrode work?

Key points

- Potentiometry
- Measurement of electrical potential caused by H⁺ concentration difference across pH sensitive glass
- Other junctions in the circuit are designed to have constant potentials

General explanation

Two half cells, the Ag/AgCl measuring electrode and the Hg/HgCl reference electrode form a circuit which, with one exception, has interfaces of known and constant EMF's. This exception occurs across pH sensitive glass that separates the sample from the Ag/AgCl electrode. An EMF occurs across the glass that is dependent on the difference in H⁺ concentration (activity) across the glass. The overall EMF in the circuit is therefore dependent on this single potential.

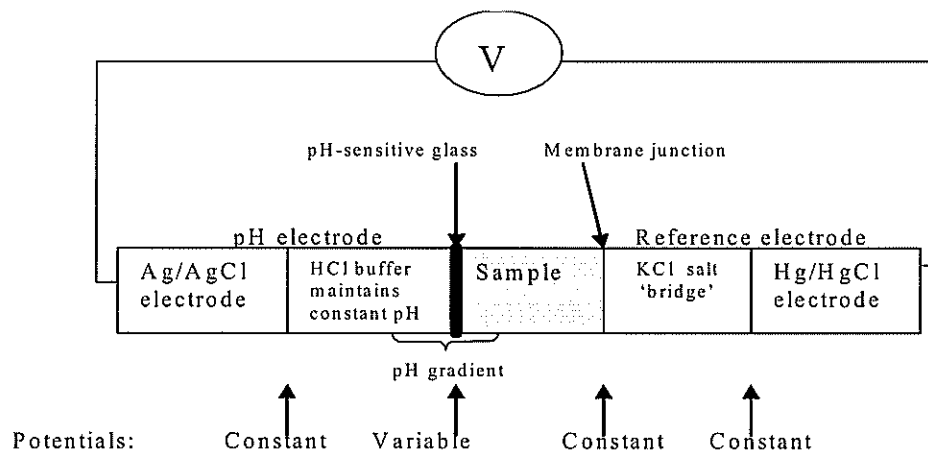

The electrode chain of pH measurement. In this example the reference electrode is depicted as Hg/HgCl (calomel)

What is pH sensitive glass?

The glass is typically silicate and contains metal ions (Na⁺ or Li⁺). It has a thin hydrated outer layer. The metal ions are free to move within both the glass and the hydrated layer but the H⁺ ions can enter the hydrated layer but not the glass. On both sides of the glass (ie in sample and buffer) the H⁺ ions enter the hydrated layer and exchange with the metal ions. This causes the metal ions to leave the glass to replace those lost in exchange with the H⁺ ions. Because of the buffer, on the Ag/AgCl electrode side electrical potential is kept constant. The exchange on the sample side is not buffered and an EMF is therefore set up across the glass caused by a

	net movement in metal ions across the glass. This EMF is dependent on the H ⁺ activity in the sample.
Magnitude of EMF Rosenthal's correction factor	Linear change of ~ 61.5 mV per pH unit at 37 °C Allows you to predict the patient's pH given the pH produced from an analyser working at 37°C $pH = pH_{(37^{\circ}C)} - 0.0147 (\text{Body temp}^{\circ}C - 37)$
Reference electrode	Negative terminal. May be Hg/HgCl or Ag/AgCl. Provides a stable potential against which the measuring electrode is compared.
Importance of temperature	The dissociation of acids and bases increases with temperature. The electrode temperature is therefore kept constant at 37°C. If a sample is taken from hypothermic patient and analysed at 37 °C there will be more dissociation in vitro than there was in vivo. A correction factor is therefore required to give the patient's true pH
What is a buffer?	A buffer solution is one which resists change in pH when small quantities of an acid or alkali are added to it. The solution must contain things which remove any hydrogen or hydroxide ions that are added to them. Buffer solutions may be acid (eg ethanoic acid –ethanoate; HCl) or alkali (eg Ammonia - ammonium chloride)
What is the salt-bridge?	A saturated electrolyte solution eg KCl or sodium formate (HCOON) that maintains electrical contact between the coated Ag or Hg reference wire and the sample. Sometimes described as a KCL gel or a porous plug filled with KCL. By using saturated salt solutions the concentrations of the salts are maintained and the PD produced is maintained.
Importance of calibration	The pH electrode are like batteries and run down with time and use. Calibration with buffers of different pH is required on a regular basis. The pH is checked against the potential developed by the electrode. A pH of 7.0 gives a potential of 0 mV and should change by ± 60 mV per whole number unit pH at 25 °C.

Differences between texts	The reference electrode in Parbrook and the ABL manual is Ag/AgCl. Most other texts (Al-Shaikh, A-Z, S&F, Sykes, Brandis,) describe a Hg/HgCl (calomel) reference electrode. The radiometer website lists many different types of reference electrodes and salt bridges.
---------------------------	--

Ion sensitive field effect transistor

What is it?	A field effect transistor, is a transistor, in which the flow of current is controlled by a voltage applied across it. In the ISFET the voltage is applied by a chemical reaction which, in turn, can be made to reflect local pH.
-------------	--

Measurement of PCO₂

Methods	CO ₂ electrode Estimation from ET CO ₂ Rebreathing technique
---------	--

Astrup interpolation technique
Haldane apparatus

1) Severinghaus CO₂ electrode

A modification of the pH electrode. CO₂ penetrates a CO₂ permeable silicone membrane and dissolves in a bicarbonate electrolyte solution to form carbonic acid. The resulting pH is linearly related to log PCO₂ and is measured by the pH electrode component.

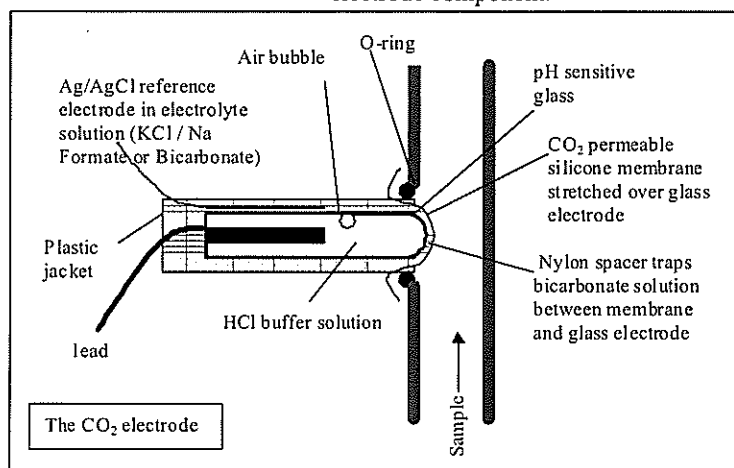

CO₂ reference electrode

The reference electrode is incorporated into the CO₂ electrode housing and is in contact with the same bicarbonate electrolyte solution as is in the spacer. (All texts describe a Ag/AgCl reference electrode except Scurr and Feldman who state Hg/HgCl and Brandis who states they may be either Ag/AgCl or Hg/HgCl.)

Steps in CO₂ measurement:

- | | |
|-----------------------------------|--|
| 1. Transport of CO ₂ | CO ₂ in sample permeates the silicone membrane |
| 2. Dissolution of CO ₂ | CO ₂ dissolves in bicarbonate electrolyte solution which is trapped in the nylon spacer. This produces carbonic acid:
$H_2O + CO_2 \rightleftharpoons H_2CO_3$ |
| 3. Dissociation of carbonic acid | Carbonic acid dissociates according to the following equilibrium reaction:
$H_2CO_3 \rightleftharpoons H^+ + HCO_3^-$ |
| 4. pH change | The release of H ⁺ ions changes the H ⁺ activity which is measured by the pH electrode component |

Points:

- i) Requires calibration with known CO₂ concentrations
- ii) Response time slower than pH electrode
- iii) Maintained at 37 °C
- iv) Initial measurements are in concentrations and are then converted to partial pressures. Thus, for barometric pressure of 100 kPa, SV_P water at 37 °C of 6.3 kPa and [CO₂] of 5 %:
 $PCO_2 = 5 / 100 \times (100 - 6.3) \text{ kPa} = 4.7 \text{ kPa}$

2) Estimation from ET CO₂

Problems

Difference of 0.7 kPa in normal lung, more in diseased
 Difference increases in low cardiac output states

3) Rebreathing technique

Patient rebreathes until gas in bag is at equilibrium with mixed venous blood. Normally the difference between venous and arterial PCO₂ is 0.8 kPa and this is subtracted from the bag PCO₂. Cardiac output must be normal.

4) Astrup interpolation

CO₂ dissociation equation



Basic method

Linear relationship between pH and log PCO₂. pH of blood is measured before and after equilibration with two known tensions of CO₂. pH measurements from the two known equilibrations are then plotted on a graph against their respective CO₂ tensions. A line is drawn between them and the test pH is plotted on that line. The PCO₂ is read off the y axis.

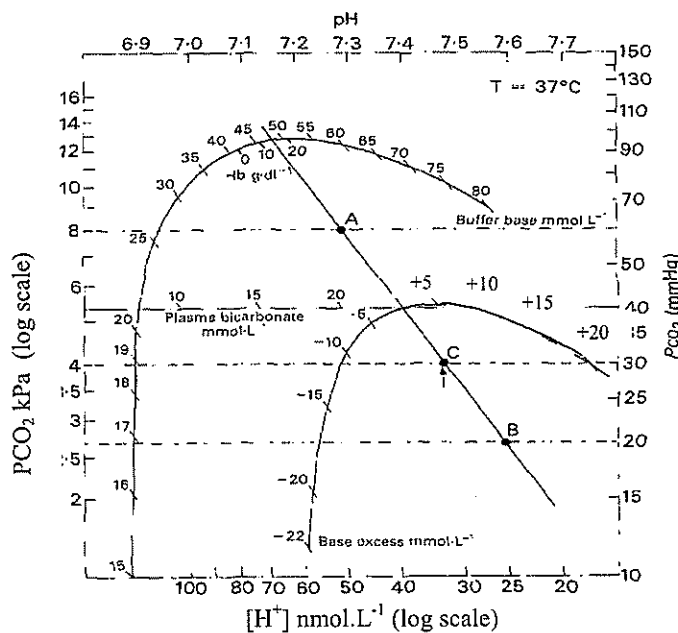

Astrup interpolation using the Siggaard-Anderson normogram. Point A and B have been obtained by measuring the pH of two samples of the patient's blood which have been equilibrated with two different O₂-CO₂ gas mixtures. Here they were 8kPa and 2.7 kPa. A line is then drawn between A and B. The pH of the patient's blood is then measured and plotted on the line and the CO₂ read off. BE is obtained from the point at which the line crosses the lower BE curve.

What determines the position and slope of the line?

Slope - haemoglobin concentration (increased haemoglobin concentration increases slope due to increase in overall buffering capacity)
 Position - metabolic component of buffer. Metabolic acidosis shifts line to left and metabolic alkalosis shifts line to right.

Standard bicarbonate

Bicarbonate concentration in plasma of fully oxygenated blood which has been equilibrated with PCO₂ of 5.3 kPa at 37 °C. Calculated from PCO₂ and pH.
 Normal range = 22 - 26 mmol /L

Actual bicarbonate	Amount of bicarbonate present in plasma. Calculated as above. Normal value = 24 mmol / L
Base excess	Amount of strong acid or alkali required to titrate 1L of blood back to a pH of 7.4 at 37 °C.
Normal range = ± 2 mmol / L	
Buffer base	Sum of all buffer anions in blood (Hb, bicarbonate, protein, phosphate) Normal value = 44 - 48 mmol/L
Normal buffer base	Takes into consideration the Hb concentration Normal value = $41.7 + (0.42 \times \text{Hb})$

Alpha stat and pH stat

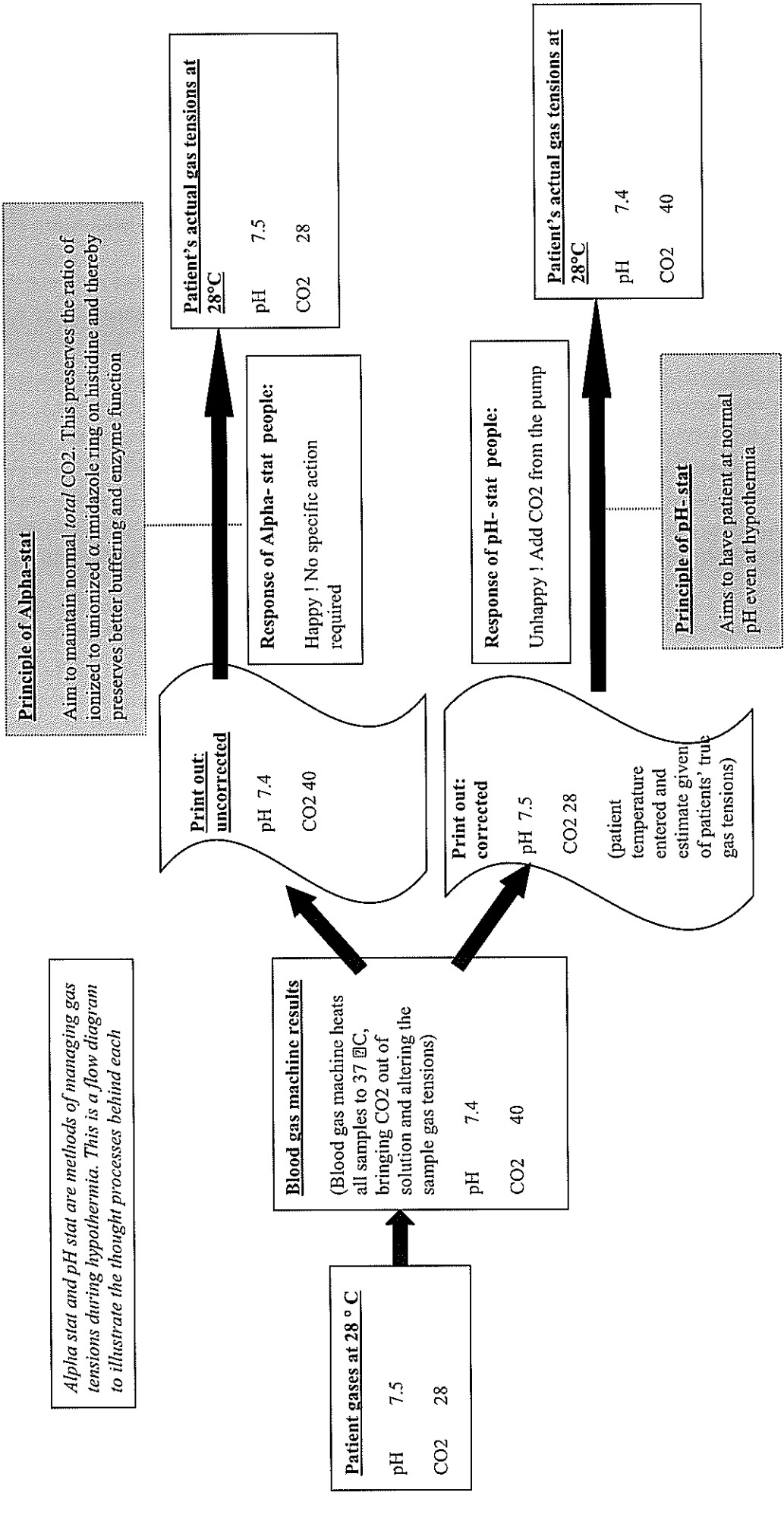

Alpha stat and pH stat are methods of managing gas tensions during hypothermia. This is a flow diagram to illustrate the thought processes behind each

Principle of Alpha-stat
Aim to maintain normal total CO2. This preserves the ratio of ionized to unionized α imidazole ring on histidine and thereby preserves better buffering and enzyme function

Principle of pH-stat
Aims to have patient at normal pH even at hypothermia

Which is better?
Much debate, but no one has shown a major difference in outcome. Miller says 50% of centres have adopted alpha stat in USA and UK.

Claims for Alpha-stat
Limits myocardial damage
Better sensitivity to adrenaline; VF less likely
Less cognitive dysfunction post-op possibly due to lower CBF and less embolism compared with pH stat: cerebral autoregulation preserved.

Claims for pH-stat
Possible cerebral metabolic benefits – faster more homogenous cooling; less left shift in ODC → ↑ O2 delivery

HEAT AND TEMPERATURE

Heat

Definition	Molecular kinetic <i>energy</i> which can be transferred from a hotter substance to a colder.
SI unit of heat	joule
Other units	1 Calorie = 1 kcal = 1000 calories \cong 4200 joules

Temperature

Definition	<i>Measure</i> of the thermal state (relative "hotness or coldness") of the substance. Thus, it is a measure of kinetic energy possessed by molecules.
------------	--

Specific heat capacity

Definition	Heat required to raise the temperature of <i>1 kilogram</i> of a substance by 1 Kelvin Energy required = mass x SHC x ΔT
Units	$J\ kg^{-1}\ K^{-1}$

Heat capacity

Definition	Heat required to raise the temperature of <i>an object</i> by 1 kelvin
Units	$J\ K^{-1}$ (Units can also be written per $^{\circ}C$ as $1\ K = 1\ ^{\circ}C$)
Units for gases	As above or $J\ l^{-1}\ ^{\circ}C^{-1}$
Specific heat capacity of man	$\sim 3.5\ kJ\ kg^{-1}\ ^{\circ}C^{-1}$
Heat capacity of a man	$\sim 245\ kJ\ ^{\circ}C^{-1}$
Specific heat capacity water	$4.18\ kJ\ kg^{-1}\ ^{\circ}C^{-1}$ (i.e. relatively high) = $1\ kcal\ kg^{-1}\ ^{\circ}C^{-1}$ = 1 Calorie (dietetics)
Specific heat capacity of blood	$3.6\ kJ\ kg^{-1}\ ^{\circ}C^{-1}$
Specific heat air	$1.01\ kJ\ kg^{-1}\ ^{\circ}C^{-1}$ or $1.2\ J\ l^{-1}\ ^{\circ}C^{-1}$ Gases have low HC. Small heat transfer can cause significant temperature change in gas

What determines the temperature rise of an object being heated?

$$\Delta T = \text{Energy added} / \text{Mass} \times \text{SHC}$$

How much energy do you need to heat an object?

$$\text{Energy} = \text{Mass} \times \text{SHC} \times \Delta T$$

Latent heat

Latent heat of fusion

Heat required to change solid to liquid without a change in temperature is the energy required to break the bonds that hold particles together.

Latent heat of vaporisation

Heat required to change liquid to vapour without a change in temperature is the energy required to pull the particles apart completely.

Latent heat of crystallisation

Solid dissolving in or crystallisation out from a liquid

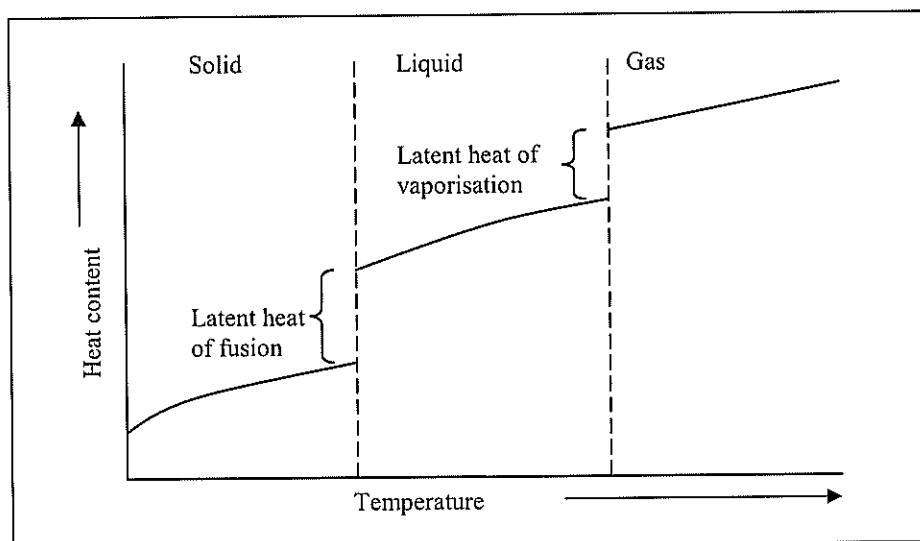

Note 1:

Heating a substance increases the kinetic energy of the molecules and increases its internal energy and temperature. When you change the state of a substance its internal energy changes but its temperature doesn't because the change of state alters the potential energy not its kinetic energy. Thus each molecule of steam leaving boiling water has more potential energy than each molecule in the water even though all molecules are at 100°C and have the same amount of kinetic energy. Boutal et al A2-level Physics

Note2: What is Potential energy?

Potential energy is the energy of an object or a system due to the position of the body or the arrangement of the particles of the system. It exists when a force acts upon an object that tends to restore it to a lower energy configuration eg. This force is often called a restoring force. For example, when a spring is stretched to the left, it exerts a force to the right so as to return to its original, un-stretched position. Similarly, when a mass is lifted up, the force of gravity will act so as to bring it back down. The action of stretching the spring or lifting the mass requires energy to perform.

Specific latent heat

Definition

Heat required to convert 1 kilogram of a substance from one phase to another at a *given temperature*. Therefore, lower the temperature, the more energy required

Units

Water at 37 °C
Water at 100 °C

J kg⁻¹
2.42 MJkg⁻¹
2.26 MJkg⁻¹

Variation in LH with starting temperature N₂O

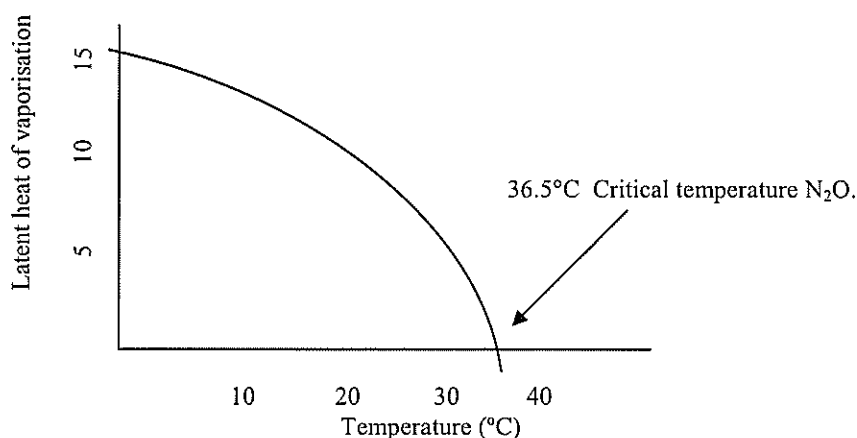

Examples of relevance to anaesthesia

- 1) High specific heat capacity of water Used as water bath for eg Boyle's bottle vaporisers to maintain steady temperature.
- 2) Low specific heat capacity of gases Cool easily and can be heated easily
- 3) Latent heat of vaporisation
 - i) Ethyl chloride → cools skin with vaporisation → ↓ nerve conduction → analgesia
 - ii) Vaporisation volatiles → cooling → ↓ SVP → ↓ vaporisation ∴ temperature compensation required
 - iii) Vaporisation N₂O → cooling → pressure gauge reads low → after cylinder closed temperature and pressure gradually rises and pressure will rise.
 - iv) Oxygen storage
 - Stored in VIE at -160 °C at 7 bar (CT = -119 °C)
 - Vaporisation and vacuum insulator keep it cold
 - If use ↑ → ↑ vaporisation, ↓ temp, ↓ vapour press ∴ O₂ is warmed as it leaves VIE in press raising vaporiser
 - If use ↓ → gradual ↑ temp in VIE → blow-off through safety valve → re-cooling
 - v) Patient breathing dry gases will lose energy and cools.
- 4) Comparison of heat required (lost) to warm air and that required to humidify air:

Warming air from room temperature in the upper trachea:

$$\begin{aligned}
 \text{Energy lost} &= \text{Gas Flow} \times \text{Specific heat capacity of air} \times \text{Temperature difference} \\
 &= 7 \text{ l min}^{-1} \quad 1.2 \text{ J l}^{-1} \text{ } ^\circ\text{C}^{-1} \quad (34 - 22 \text{ } ^\circ\text{C}) \\
 &= 118 \text{ J min}^{-1} \\
 &= 1.96 \text{ W}
 \end{aligned}$$

Humidifying dry gases:

$$\begin{aligned}
 \text{Energy lost} &= \text{Gas Flow} \times \text{Specific latent heat of vaporisation} \times \text{Humidity trachea} \\
 &= 7 \text{ l min}^{-1} \quad 2.42 \text{ MJ kg}^{-1} \quad 34 \text{ mg l}^{-1} \\
 &= 576 \text{ J min}^{-1} \\
 &= 9.6 \text{ W}
 \end{aligned}$$

Thus total heat lost in warming and humidifying dry gases at room temperature = 1.96 W + 9.6 W = 11.56 W
 This illustrates that the heat lost in humidifying dry gases is much greater than that lost warming them. The sum of the energy lost is ~ 15% of total basal losses (80 W). Particular problem in children.

Adiabatic process

Definition

That in which no heat flows into or out of the system; there is not transfer of heat with the environment

Why?

For a gas to expand, energy is required to overcome Van der Waals' forces of attraction between molecules. If the gas is allowed to expand slowly, the energy may come from environmental exchange. This is called an isothermal transformation.

Thermodynamic isolation

An adiabatic process may occur in a system that is thermodynamically isolated in that there are a) thermodynamically insulated walls or b) the process happens in an extremely short time so there is no opportunity for significant heat exchange. When gas expands rapidly, there is no time for exchange to occur with the environment so the energy comes from the kinetic energy of molecules of the gas itself → cooling. Equally, when a gas is suddenly compressed and there is no time for the heat released to dissipate, the immediate surroundings are heated.

Examples:

Cryoprobe - CO₂ or N₂O expansion
Sudden compression of gases in pipeline when cylinder turned on → heating of pipeline.
Sudden expansion of gas in reducing valve → icing
Diesel engine- adiabatic heating on the compression stroke ignites fuel

TEMPERATURE

Temperature

Scales	Fahrenheit Kelvin (Absolute) (The true SI unit) Celsius
Kelvin	An absolute scale in that there is a (theoretical) true zero in zero K where molecular motion ceases. This scale must be used when dealing with gas law equations.
All scales have at least one fixed point	Fahrenheit -? Body temp. assumed at 100° F Celsius - Freezing and boiling points of water Kelvin - Triple point of water.
Relationship between Celsius and Kelvin	1 ° in Celsius scale same magnitude as 1 unit in Kelvin scale. Temperature (K) = Temperature (°C) + 273.15
Triple point water	0.01 ° C and 273.16 K
Standard temperature and pressure	0°C or 273.15 K and 101.325kPa or 760 mmHg

Measurement of temperature

Non-electrical / Direct reading	Liquid filled manometer	- mercury - alcohol
	Dial	- bimetallic strip - Bourdon gauge
Electrical / Remote reading	Chemical	
	Resistance thermometer Thermistor Thermocouple Infrared (Thermopile) Transistor	

Non-electrical / Direct reading

1) Liquid filled manometers

Advantage Simple, linear expansion with temperature

Disadvantage Slow
Breakage and injury
Non-remote
Intermittent, non-recording

Advantage of alcohol Cheaper
Low temperature (mercury solidifies at -39° C)

Disadvantage of alcohol Not suitable for high temperatures (boils at 78.5 °C)
Less linear

2) Dial thermometers

Bimetallic strip - a coil of two metals with different coefficients of expansion.

Bourdon gauge - Works on principle of the 3rd perfect gas law (at constant volume the absolute pressure of gas varies with the absolute temperature) Hollow, coiled steel tube may contain mercury or volatile liquid.

3) Chemical

i) Strip contains rolls of cells which contain dye and melt at certain temperature. The higher the temperature, the more cells melt and the more dye is released.

ii) Cells have different long chain polymers whose optical properties change with temperature.

iii) Cholesteric liquid crystals change colour with temperature

Electrical/ Remote reading

Resistance thermometer

Principle

Resistance of metal *increases* linearly with temperature. Resistor incorporated into Wheatstone bridge. Usual metal is platinum (expensive) or copper or nickel.

Problems

Slow, bulky

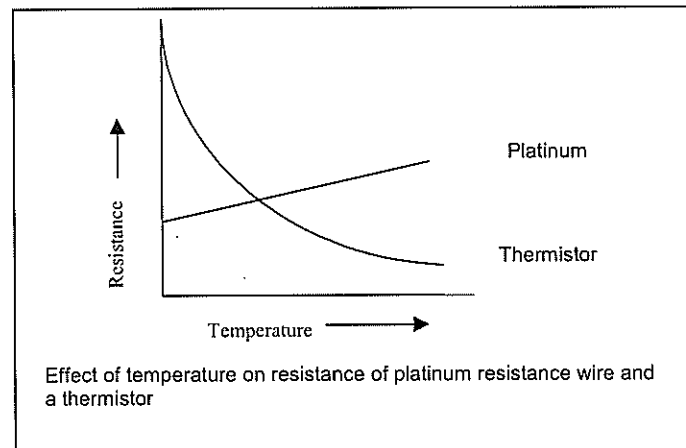

Thermistor

Principle

Small bead whose resistance changes with temperature. Usual is a metal oxide semiconductor (cobalt, manganese, Hg, Zn or nickel) in which the resistance *decreases* exponentially with increasing temperature. (Note: resistors can also be made in which resistance *increases* with increasing temperature)

Main differences from resistance wires

Usually semiconductors so resistance ↓ with temp ↑
Material usually metal oxide, ceramic or polymer as opposed to metal
Temperature measurement more precise over a narrower range

Advantage	Greater change in resistance per unit change in temperature than with resistance wire, ∴ more sensitive. Small Faster response time Cheaper than platinum resistance wire
Disadvantage	Calibration may change if subjected to severe temperatures Hysteresis Ageing of thermistor

Thermocouple

Seebeck effect One of three thermoelectric effects. Usually refers to the generation of an electromotive force (voltage) whenever there is a temperature gradient along a conductive metal.

Principle If a conductor is heated at one end, electrons will flow to the opposite end creating a relatively negative charge at that cooler end. The voltage difference along that conductor is proportional to the temperature difference between the two ends.

Construction of thermocouple

- Two dissimilar metals are joined together creating two junctions.
- Measuring junction: the sensing tip of the probe
- Reference junction: this must either be kept at constant temperature or the temperature must be measured and adjustments made in the algorithm,
- There are numerous metal combinations that can be used. One example is copper and constantan (copper/nickel alloy). The response with Copper / Constantan is $40\mu\text{V}/^\circ\text{C}$
- Voltmeter

Typical thermocouple. At the junction between any two dissimilar metals there is a flow of electrons from one metal to the other. This creates a voltage across the junction. The flow and voltage vary with temperature. Thus, when two dissimilar metals are joined and the two junctions are at different temperatures, the voltages at each junction will differ. By keeping the reference junction at constant temperature (and therefore voltage), any temperature change relative to that at the measuring junction will cause a proportional measurable voltage. Hence, the standard design of a thermocouple is shown below.

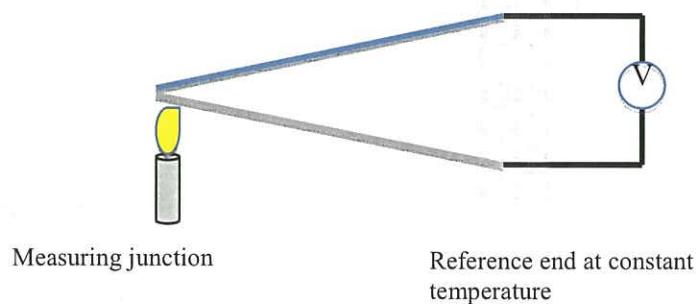

Advantage	Stable calibration Accurate to 0.1°C
-----------	---

Multiple different applications
References differ as to whether temperature/voltage relationship is linear. Almost certainly is over specified temperature ranges

Infrared thermometers

Measure infrared energy from eg tympanic membrane.
Laser dot helps aim the device but does not form part of the measurement
Detector is a thermopile which is a mass of hundreds of thermocouples incorporated into an area of several square millimetres. The reference temperature is measured or maintained constant by means of a heat sink. (See diagram below).
Thermopiles are also used as oximeter and capnograph sensors.

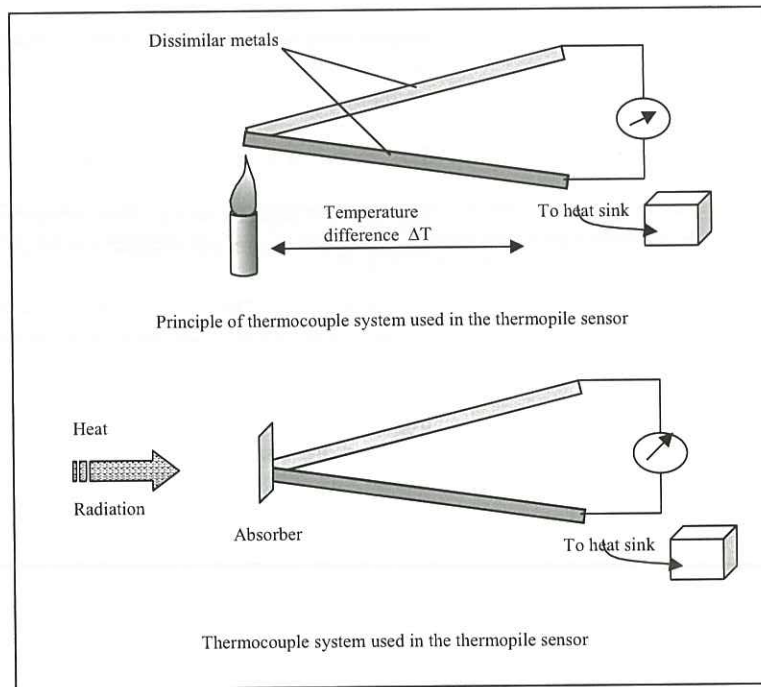

4) Transistor detectors

Voltage across transistors is temperature dependent

MEASUREMENT SITE	TEMPERATURE COMPARED WITH CORE	POTENTIAL PROBLEMS
Buccal	- 0.2 – 0.4 °C	
Nasopharyngeal	≅ brain	
Tympanic membrane	≅ brain & oesoph	Wax, obstruction ↓ accuracy Perforation
Axilla	- 0.4 – 0.7 °C	
Rectum	≥ core	Perforation Aesthetic Slow to equilibrate
Lower oesophagus	- 0.5 °C	Accurate reflection of core Cooling by trachea if too high
Pulmonary artery	≅ core	
Bladder	≅ core	Reasonable correlation
Skin	≤ core	Dependent on perfusion

Note: "Core" implies the temperature of the vital organs and some of the deep tissues of the limbs.

What is a vapour?

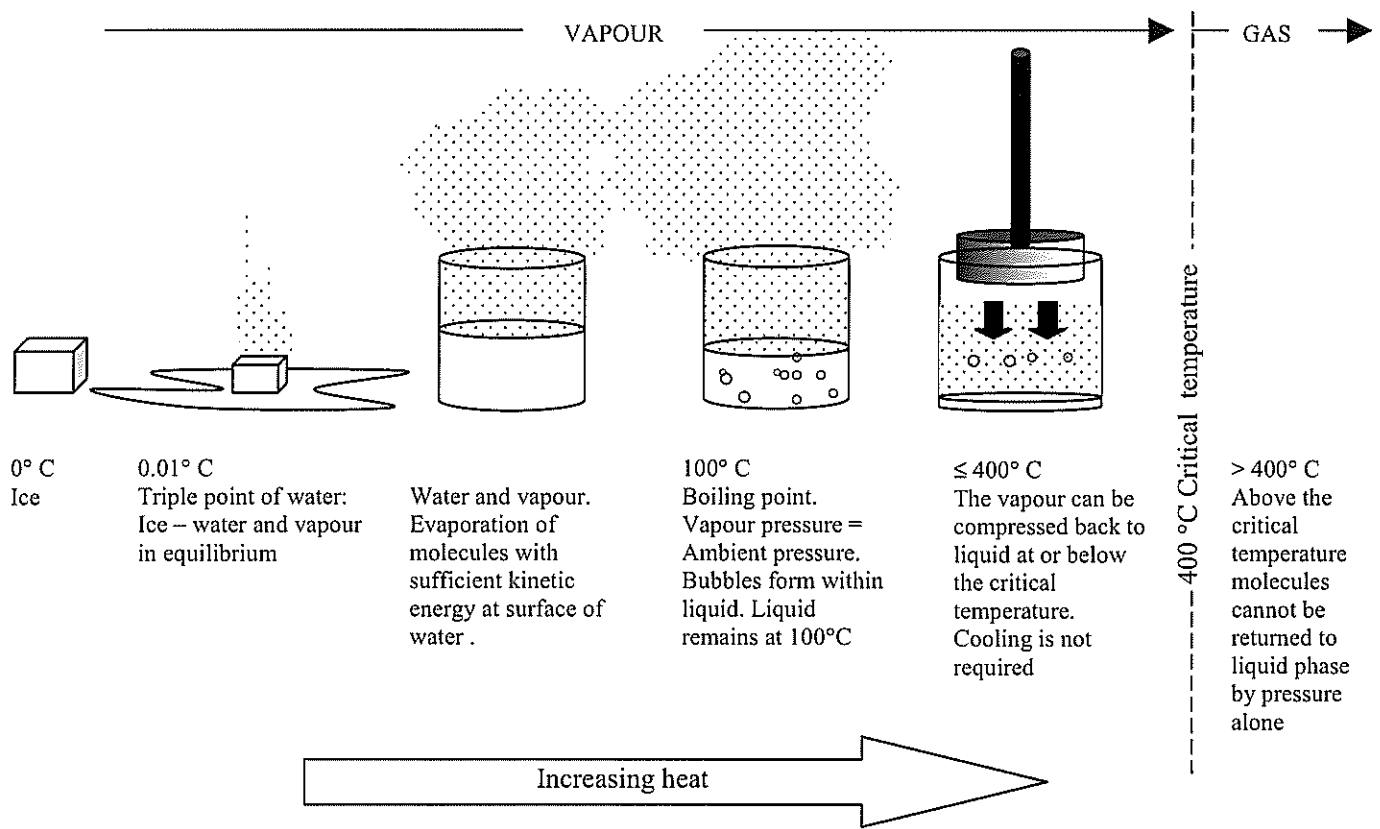

HUMIDITY

Problem if no humidification-

Cooling - particular problem in neonates

Dehydration

↓ ciliary function - ↓ mucus flow

- post-op. pulm. complications *

- mucosal degeneration

- squamous metaplasia

- tracheobronchitis

- bronchopulmonarydysplasia

- infection/ mucus plugs/collapse

↑ risk sparks and explosion

↓ comfort in theatre environment (aim for 50 - 70 %) * (Chalon et al. Anesthesiology. 1979)

Normal humidification-

Nose

Nasopharynx

Oropharynx

Physical principles

When is a vapour saturated?

When number of molecules leaving liquid phase equal the number entering liquid phase - ie. The liquid and vapour phases are in *equilibrium*.

Definition of SVP

Pressure exerted by such a vapour

Definition of fully saturated air

Air containing water vapour at partial pressure equal to SVP for that temperature.

Effect of temperature on SVP

As temperature increases, the kinetic energy of molecules ↑ → ↑ number molecules able to leave liquid phase → ↑ SVP

Effect of temperature on water content of saturated air (assuming a water source)

↑ temp → ↑ water content

↓ temp → ↓ water content

Absolute humidity

Actual mass of water vapour carried in a cubic metre air.

Relative humidity

Ratio of mass of water vapour in a given volume of air to the mass required to saturate it at the same temperature and pressure ie Ratio of absolute humidity to humidity at saturation.

Humidity at saturation

Max amount of water that can be carried in a cubic metre of air at a given temperature.

What happens to relative and absolute humidity of a given volume of air if the temperature rises?

Absolute humidity stays the same

Relative humidity falls

Relative humidity in terms of vapour pressure

Actual vapour pressure / saturated vapour pressure

Why?

Relative humidity = mass water present / mass to saturate

Universal gas constant

$$R = PV / nT$$
$$P = n (RT/V)$$

Thus if T and V constant for a given gas whose gas constant is R, the pressure exerted by the gas will be proportional to the number of moles. ($P \propto n$)

Therefore, as $n \propto$ mass, Pressure \propto mass of water

Thus, relative humidity

$$= P_{\text{actual}} (V/RT) / P_{\text{saturated}} (V/RT)$$

Typical values:

Humidity at saturation air at 20° C	17 gm ⁻³
Relative humidity air entering trachea	~ 100 %
Humidity at saturation trachea (34 °C)	34 gm ⁻³
Humidity at saturation lung air (37°C)	44 gm ⁻³
Vapour pressure lung air	6.3 kPa (47 mmHg)
SVP water vapour at BTPS	47 mmHg

Measuring humidity

1) Hair hygrometer

As relative humidity increases, hair lengthens and moves a light lever. Relatively inaccurate ($\pm 2\%$) but still widely used. A membrane may be used instead of a hair.

2) Wet and dry bulb hygrometer (Psychrometer)

The standard instrument for measuring climatic relative humidity. Instrument contains two thermometers. The 'dry' thermometer reads ambient temperature. The other thermometer is surrounded by a wet wick that cools the thermometer as water evaporates. The degree of evaporation from the wet wick and, therefore, the cooling of the thermometer, is dependent on the relative humidity. The difference in temperature between the two thermometers is recorded and is related to the relative humidity via tables or slide rule. Whirling and aspiration types.

3) Condensation methods

i) Regnault's hygrometer

Air, blown through a silver tube containing ether, results in cooling of the tube due to vaporisation of ether. The air outside the tube is consequently cooled. This reduces the amount of water vapour that can be held in the air so that, eventually, the vapour becomes saturated. When the SVP for the new, cooler temperature is reached, condensation will form on the surface of the tube. The temperature at which this occurs is called the dew point. Tables are then consulted and the humidity at saturation at this new temperature obtained. This, therefore, is the absolute humidity. To convert to relative humidity, consult tables again and divide by the maximum mass of water that could be carried at saturation at the original temperature.

Thus relative humidity =

Humidity at saturation (dew point)

or, if tables give SVP rather than mass

Humidity at saturation (original temp)

$$\frac{\text{SVP (dew point)}}{\text{SVP (original temp)}}$$

ii) Chilled mirror hygrometer

The modern, widely used application of Regnault's hygrometer. Air is passed through a sample chamber that contains a coolable mirror and an optical system that measures reflectivity. The mirror is cooled to dew point and this is detected by a change in reflectivity and optical output.

4) Humidity transducers / sensors

Resistance of substance (eg a salt) decreases with increasing absolute humidity

Capacitance increases with absolute humidity. Impedance decreases

Thermal conductivity : The TC of humid air is greater than dry air. The TC of the sample is compared with that of a sealed dry reference gas.

5) Weighing/absorption

Water vapour is absorbed in silica gel or anhydrous calcium chloride and change in weight measured.

6) Mass spectrometry

Measures amount of water vapour in given volume of gas.

7) UV or IR absorption

Water vapour absorbs UV and IR radiation

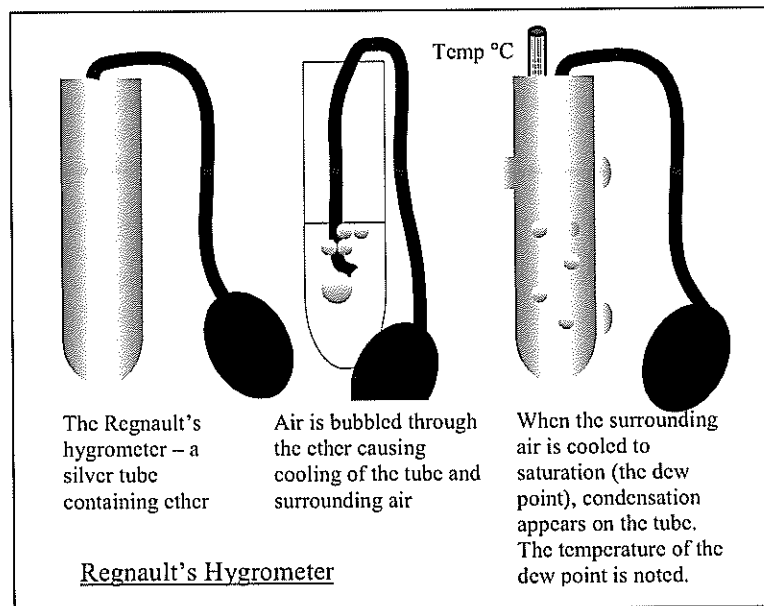
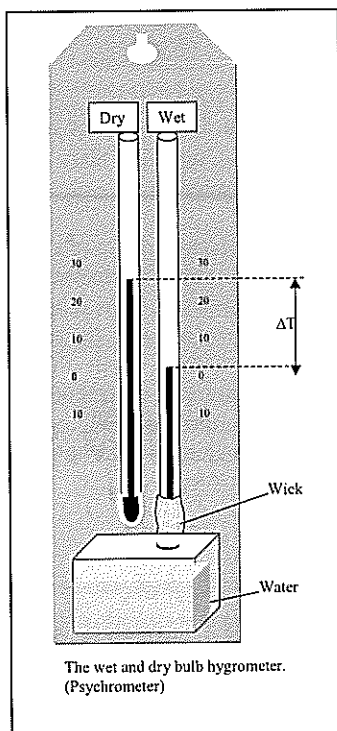

Methods of humidification

Definitions:

Humidifier

Produces water vapour - molecular water

Nebuliser

Produces aerosol - droplets of water in gas

Why might a humidifier with 100% humidity at its output produce much lower values in the lungs?

Because gases from humidifier may be 100 % saturated at room temperature but less than 100% at body temperature

How to get over this problem

Maintain inspired gases at body *temperature* with relative *humidity* of 100%. *

Supersaturation (adding mist of water droplets which vaporise when temperature ↑ and relative humidity ↓)

Length of time a droplet remains suspended in air depends on

Size - smaller droplet, greater stability

Humidity - Lower the environment humidity, the faster the evaporation of droplet.

Target for droplet

Small bronchioles and beyond

Ideal size

1 - 10 μm

Principle methods

i) Natural: Nose (nasopharynx) + face mask

ii) Circle

Relative humidity - start ~ 30 %
- 1.5 hrs ~ 60%
- low flow ~ 93 %

CO₂ absorption by soda lime → heat and moisture

$\text{CO}_2 + 2\text{NaOH} \rightarrow \text{Na}_2\text{CO}_3 + \text{H}_2\text{O} + \text{heat}$

$\text{Na}_2\text{CO}_3 + \text{Ca}(\text{OH})_2 \rightarrow 2\text{NaOH} + \text{CaCO}_3$

Note: NaOH is regenerated hence little needed in mixture

Constituents of soda lime

80% Calcium hydroxide

4% Sodium hydroxide

Potassium Hydroxide (small fraction)

14-20% water

Silica to maintain granular structure. Mesh size 4-8

pH indicator

iii) Heat and moisture exchanger (HME)

Warm expired air meets cool interface and condenses

→ Inspired gases pick the water on HME

NB: A temperature difference is required across the interface.

Full saturation possible?

No, temperature too low

Two principle types HME

1. Hydrophobic

Repels moisture – droplets sit on paper surface

Eg Ceramic pleated membranes

Small pores of 2 μm ca act as microbiological filter

2. Hygroscopic

Moisture retaining – paper becomes wet

Eg Paper coated with eg CaCl₂

Greater proportion of expired water vapour adsorbed on surface - ↑ efficiency.
 May be combined with an electrostatic filter. This is a charged layer that attracts particles.

Efficiency reduced

Dry inspired air
 Hot climate
 High flows or large Vt
 Should be placed on ETT or efficiency reduced

Problems

↑ resistance
 ↑ dead space by up to 100 mls (Pall filter)
 Infection

iv) Heated humidifiers

Components

Water bath with thermostatically controlled heating element
 Heated tubing with water traps

Efficiency

Capable of fully saturating and heating inspired gases to 37°C despite high flow rates
 Far superior to HME
 Heated delivery hoses optional but prevent cooling and loss of humidity in inspiratory limb of circuit

Problems

Cost
 Storage and servicing
 Water rain-out in tubing
 Extra disconnection risk
 Infection hazard
 Potential for burns
 Drowning

v) Active

1) Mechanical nebuliser

Particle size
 Site of water deposit

eg spinning disc
 2-4 µm
 Pharynx, some bronchial

2) Venturi (eg Puriton) ± heated anvil

Particle size

1 - 20 µm (some < 1 µm)

3) Ultrasonic nebuliser

Particle size
 Site
 Possible problems

Ultrasonic transducer
 0.8 - 1 µm (ideal size)
 Alveoli
 Over hydration - water intoxication
 - hypoxia
 Difficult to sterilize
 ↑ airways resistance

4) Hot-rod humidifier

Water dropped onto heated rod in coaxial breathing system.

Performance

Device

Absolute humidity Rel. humidity (37 °C)

Cold water bubble-through (20 ° C)	17 gm ⁻³ .	< 100 %
HME (< 35 ° C)	25 gm ⁻³ .	< 100 %
Heated water bath (36 -38 ° C)	40 gm ⁻³ .	~ 100 %
Heated Bernoulli + anvil (37 °)	60 gm ⁻³ .	> 100 %
U/S nebuliser (23 - 36 ° C)	90 gm ⁻³ .	> 100 %

VAPORISERS

Classification

Method by which gas is made to flow through vaporiser

Draw over

Carrier gas drawn through the vaporiser by negative pressure downstream (usually the patient inhaling). May be placed within the breathing circuit and, by necessity, must have very low resistance. Un-calibrated and largely historical eg Goldman inhaler.

Plenum

High resistance, so carrier gases forced through under positive pressure. All modern vaporisers are of this type.

Function of a typical plenum variable bypass vaporiser

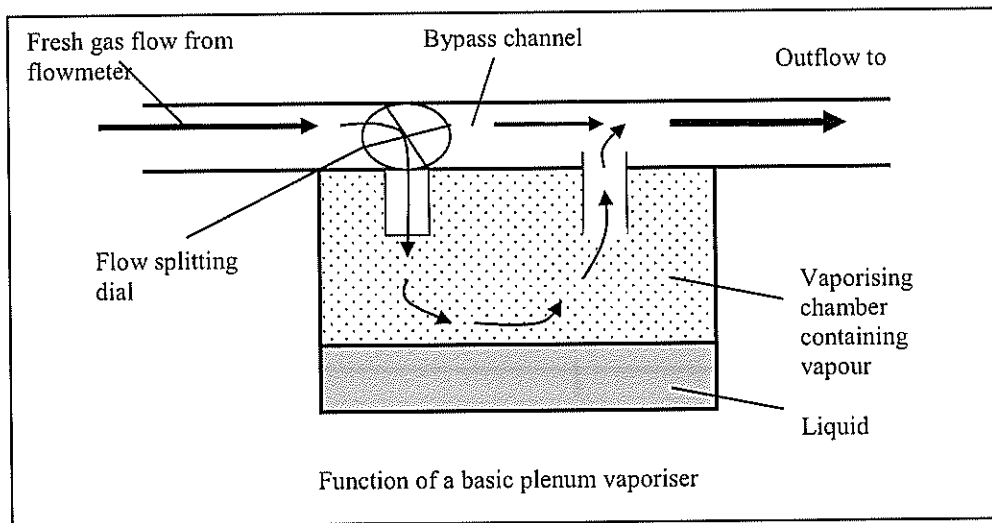

Basic principle

1. Fresh gas flow (FGF) delivered to vaporiser from flowmeters
2. A dial is manually turned to split the fresh gas in two. One portion is diverted through bypass channel (BPC) and a much smaller portion splits off through the vaporising chamber (VC).
3. The gas passing through the VC becomes fully saturated with vapour as it passes through. The concentration in the vaporising chamber depends on the SVP and is therefore predictable.
4. The VC portion, containing a known amount of agent, is added back to the bypass flow.

Example:

Imagine 1000ml/min FGF arriving at a Sevoflurane vaporiser...

When you dial up 1.12% on a Sevoflurane vaporiser the splitting ratio is 5% (950 ml through BPC and 50 ml through VC)

The 50 ml becomes saturated with Sevoflurane – what is the concentration of that vapour?

Concentration = SVP Sevoflurane / Atmospheric pressure = $22.7\text{kPa (20}^\circ\text{C)} / 101.323\text{ kPa} = 22.4\%$

How many ml Sevoflurane in each 50 ml (VC) = $22.4\% \times 50\text{ ml} = 11.2\text{ ml}$

Final concentration when VC added back to BPC = $11.2 / 1000\text{ ml} = 1.12\%$

Flow dependence

High flow

The greater the flow through the vaporising chamber, the less likely it is going to be fully saturated. Thus the vaporiser will tend to under-deliver at high flows. Flow dependence is countered by increasing the surface area by having the gas pass over metal or fabric wicks soaked in the volatile. A historical alternative is to bubble the volatile through the liquid as in the Copper Kettle and Boyle's bottle.

Low flow

At low flows the splitting ratio may be affected by differences in the amount of turbulent and laminar flow. This is affected by the density and viscosity of the gases present. At very low flows the output may vary depending on whether N₂O or Air is used.

Temperature Stability

Fluctuations in temperature within the vaporising chamber will alter the SVP and concentration of anaesthetic in the VC flow. This will lead to inaccuracies in calibration. Thermostabilisation is aided by the heavy copper casing. The casing is a 'heat sink' having high thermal conductivity and, through its large mass, a high heat capacity. Thus changes in environmental and vaporising chamber temperature are somewhat stabilised. The Boyle's bottle utilised the high heat capacity of a water bath to provide thermostabilisation.

Temperature compensation

Loss of latent heat during vaporisation results in cooling within the VC. As mentioned above this will reduce the concentration of anaesthetic in the VC flow and lead to inaccuracies in calibration. Modern vaporisers have automatic thermocompensation in the form of a valve which allows more flow through the VC when the temperature drops. Thus for a given concentration setting, the splitting ratio is increased. The valve is adjusted by means of either a bimetallic strip (a sandwich of two metals of different co-efficients of expansion), an ether-filled bellows or a metal rod.

Vaporisers avoiding the need for thermocompensation

1. Siemens vaporiser: Volatile agent is injected directly into the gas stream through a fine nozzle.
2. Heated chamber vaporiser: Volatile is heated and pressurized and then known quantities are added to the fresh gas flow
3. Desflurane dual circuit gas blender

Pumping effect

A problem in older machines was that back pressure from IPPV could cause spill of volatile back from the vaporising chamber into the bypass channel and this would increase the concentration delivered to the patient. This is prevented by a) the VC being larger than the BPC b) a pressure regulating valve or resistor downstream from the vaporiser c) a long inlet tube to the VC

Hyperbaric pressure

Vaporiser calibration is normally appropriate during hyperbaric conditions because, although the concentration of volatile delivered is reduced, the increase in barometric pressure means that the partial pressure is unchanged. It is on the partial pressure, not the concentration, that anaesthesia is dependent.

Example:

Ambient pressure
SVP sevoflurane at 20 °
[Sevoflurane] in VC

100 kPa (rounding used for this example)
22.7kPa
22.7 %

Ambient pressure
SVP sevoflurane at 20 °
[Sevoflurane] in VC

200 kPa
22.7kPa
11.35 %

Thus, for a given splitting ratio, doubling the ambient pressure will half the delivered concentration of anaesthetic agent. However, the half concentration at twice normal barometric pressure will result in normal partial pressure being delivered to the patient.

Safety issues summary

- Design features necessary for accurate calibration
- Temperature compensation methods
- 'Selectatec' design to prevent more than one vaporiser from being turned on
- Filler nozzles, port and bottles are specifically keyed
- Colour coding
- Pumping effect
- Anti-spill design (although one should avoid tipping)
- Desflurane electrical alarms

Dual-circuit gas-vapour blender

The dual-circuit gas-vapour blender (DCGVB) was created specifically for desflurane. Desflurane boils at 22.5°C, which is very close to room temperature. This means that, at normal operating temperatures, the SVP of desflurane changes greatly, with only small fluctuations in temperature. A normal plenum vaporiser is thus not sufficient to ensure accurate delivery. Additionally, on a very warm day, all the desflurane would boil, and very high (potentially lethal) concentrations of desflurane might reach the patient.

A DCGVB desflurane vaporiser requires electrical power (e.g. the TEC 6 produced by Datex-Ohmeda.) It is mounted on the anaesthetic machine in the same way as a plenum vaporiser, but its function is quite different. There are two circuits. One for the FGF and the other for the volatile-containing chamber and injector. In the latter circuit, Desflurane is heated to 39°C, vaporised and injected in small amounts under 2 bar pressure into the fresh gas flow. The exact amount of injected desflurane is known, as is the FGF into which it is injected. A transducer senses the fresh gas flow. A warm-up period is required after switching on. The desflurane vaporiser will fail if mains power is lost. Alarms sound if the vaporiser is nearly empty. An electronic display indicates the level of desflurane in the vaporiser. When FGF is altered, the desflurane injection is also altered to maintain constant concentration. The processing involves input from a differential pressure transducer which compares pressures within both circuits.

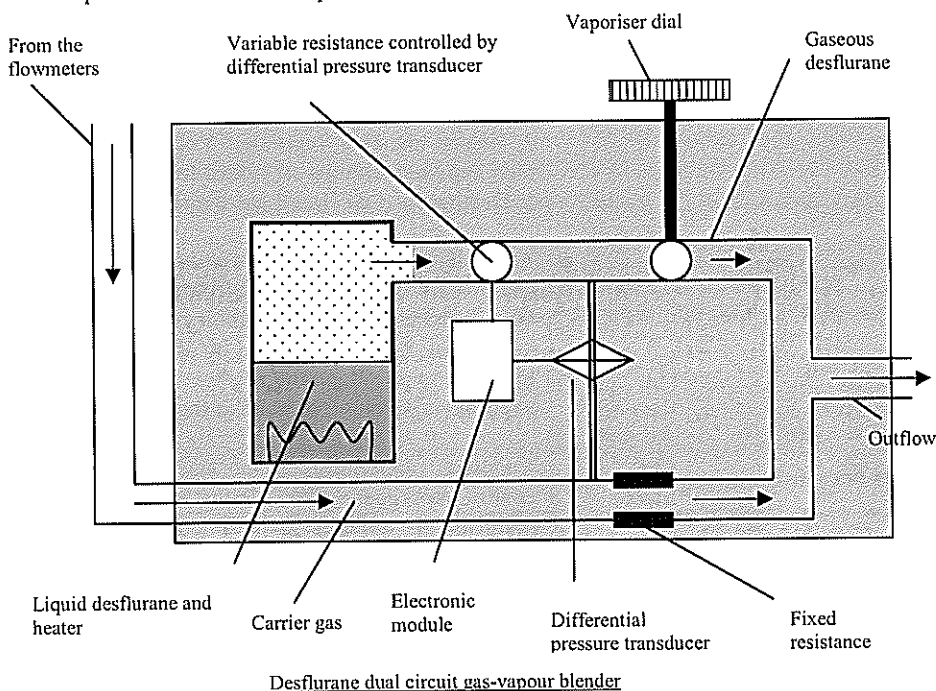

The Aladin Cassette (ADU machine, Datex Ohmeda)

This deserves special mention as it is outwardly very different from a standard plenum vaporiser and has electronic rather than manual controls. There are three parts to the system: an *electronic control* system and *bypass flow* within the anaesthetic machine and the *Aladin cassette* which is slotted in. The latter is basically just a vaporising chamber.

Once inserted in the anaesthetic machine, as with classical plenum vaporisation, there is a bypass channel and a channel leading through the vaporising chamber. The splitting ratio determines the concentration delivered to the patient and is electronically controlled by a throttle valve. The agent vaporizes freely in the cassette without pressure or heating. The vaporising chamber contains metal plates and baffles which increase the surface area exposed to the carrier gas. A heating fan in the anaesthetic machine will activate if the cassette temperature falls below 18°C.

The sensory input to the electronic control consists of a) dial setting b) vaporising chamber temperature c) bypass and chamber flow rates d) chamber pressure and e) carrier gas composition. With this input the throttle valve adjusts and readjusts the splitting ratio.

A big difference from other plenum vaporisers is that the vapour pressure within the chamber is calculated from pressure and temperature measurements rather than just assumed to be that of SVP. Another difference is that, being just a vaporising chamber, the cassettes are essentially all the same in design. Individual calibration is not required as the individuality of the agents is determined and controlled by the sensory processing within the ADU anaesthetic machine.

Aladin cassettes are agent specific, using a series of magnetic tags at the back of the cassette and agent specific filling adapters.

Drager Diva (as found on Drager Zeus anaesthetic machine)

Classification.

Plenum

Injection of volatile into measured flow

Basic principle

- Volatile is held in a storage tank →
- Passes to pressurized pump tank →
- Passes to heated evaporation chamber → Now entirely vapour at known temperature →
- Known volume (v) injected into fresh gas flow
- FGF accurately monitored and v altered accordingly

RESPIRATORY MEASUREMENT

WORK OF BREATHING

GAS VOLUME : Excluding Residual Volume

Benedict Roth spirometry
Volume – time trace (Vitalography)
Pneumotachograph with integration of flow signal
Wrights respirometers
Others: Capacitance, inductance, pneumography

GAS VOLUME: Including Residual Volume

Plethysmography
Helium dilution
N2 dilution
Radiology

CLOSING VOLUME AND CLOSING CAPACITY

Single breath N2 washout
Xenon or Argon bolus washout

ANATOMICAL DEADSPACE

Single breath N2 washout

AIRWAYS RESISTANCE

Body plethysmograph
Pneumotachograph + Oesophageal balloon
Others: Interruption, Oscillation, subtraction techniques

DIFFUSING CAPACITY

Carbon monoxide single breath and steady state method

FLOW STUDIES

Flow volume curves
Isovolume pressure-flow curves
Partial flow volume curve
Maximum breathing capacity
Spirometry

LUNG COMPLIANCE

Static compliance
Dynamic compliance

BLOOD FLOW

Total pulmonary blood flow - Fick, Indicator dilution,
Pulmonary capillary flow - Plethysmography

VENTILATION / PERFUSION RELATIONSHIPS

i) Topographical: Regional differences - xenon
- multiple inert gas
ii) Inequality of ventilation Single breath method

iii) Inequality of V/Q ratios

Multiple breath method

Blood gases and pH
A-a PO₂ difference
A-a ratio
PO₂ / FiO₂ ratio
Alveolar air equation
Shunt equation
Bohr equation

CONTROL OF BREATHING

Rebreathing

Work and Power

What is work?

Work is done when energy is transferred from one form to another usually in the setting of one force overcoming another force. eg when lifting a box against the force of gravity, kinetic energy of the box is transferred to gravitational potential energy:

$$\text{Work done} = \text{Force} \times \text{Distance}$$

Units

Joule

One joule of work =

Work done when a force of one Newton moves its point of application one metre in the direction of the force.

Work done during single inspⁿ.

$$\begin{aligned} \text{as } F &= P \cdot A \text{ and } D = V/A \\ \text{Work} &= \text{Average Pressure} \times \text{Volume change} \\ &= \text{approximately } 0.5 \text{ J / L} \end{aligned}$$

What is power?

Rate of working (work per second)

Units

Watt (= 1 joule per second)

Power in terms of volume and flow

$$\begin{aligned} \text{Power} &= \text{pressure} \times \text{volume} / \text{time} \\ &= \text{pressure} \times \text{flow} \end{aligned}$$

Actual power needed vs power used

$$\begin{aligned} \text{Power requirement of } 300 \text{ mJ breaths @ } 16 \text{ breaths / min} \\ = 300 \text{ mJ} \times 16 / 60 = 80 \text{ mW} \\ \text{Power used} = 800 \text{ mW} \end{aligned}$$

Efficiency

10% efficient with 90 % of energy being converted to heat

How does power vary with type of flow?

Laminar flow uses less energy than Turbulent flow.

Why?

Power in both situations is determined by the driving pressure and the flow rate and in turbulent flow the driving pressure is much greater for a given flow

Laminar flow: Driving pressure \propto Flow

Turbulent flow: Driving pressure \propto Flow²

Therefore, during hyperventilation

Oxygen consumption very high

What happens to the energy used in inspⁿ

$\frac{1}{2}$ used to expand elastic tissue \rightarrow stored energy for expirⁿ
 $\frac{1}{2}$ used to overcome airways and tissue resistance \rightarrow lost as heat

The pressure-volume diagram

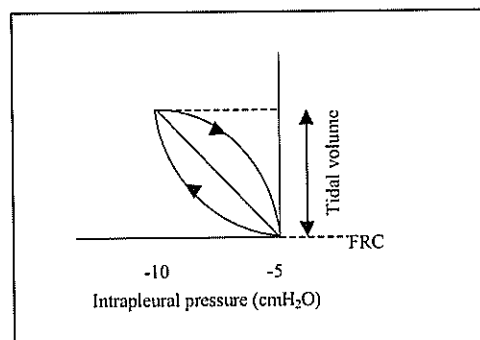

Work expanding elastic tissue from FRC

$$= \text{Average intrapleural pressure rise} \times \text{change in volume}$$

$$= (\text{Initial P} - \text{End-insp. P}) / 2 \times \Delta V$$

$$= 1/2 PV$$

This is represented in the PV graph as the shaded triangle above the $\Delta P \cdot \Delta V$ diagonal.

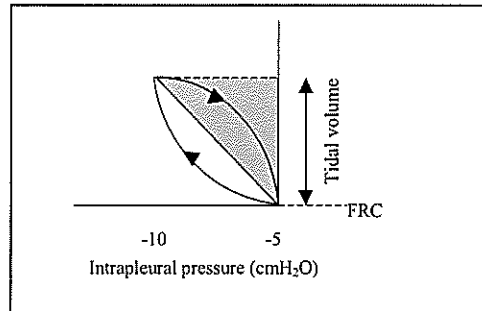

What happens to the energy used in overcoming elastic tissue?

It is stored as potential energy to be used for expiration.

What is viscous resistance?

Airways resistance (80%)
Tissue resistance (20%)

Work in overcoming airways resistance during inspiration

The bulge below the diagonal of the PV graph. Caused by the additional pressure and energy which is required to overcome frictional resistance to gas flow in the airways.

Work used in overcoming airways resistance in expiration.

The bulge above the diagonal. Energy is required to overcome airways resistance during expiration.

The energy restored as heat energy

The difference between the stored 'triangle' and the bulge above the diagonal. ie the harder it is to exhale, the more energy lost from the body and the less stored.

Which of the two diagrams below best describes the work of 'tidal' breathing?

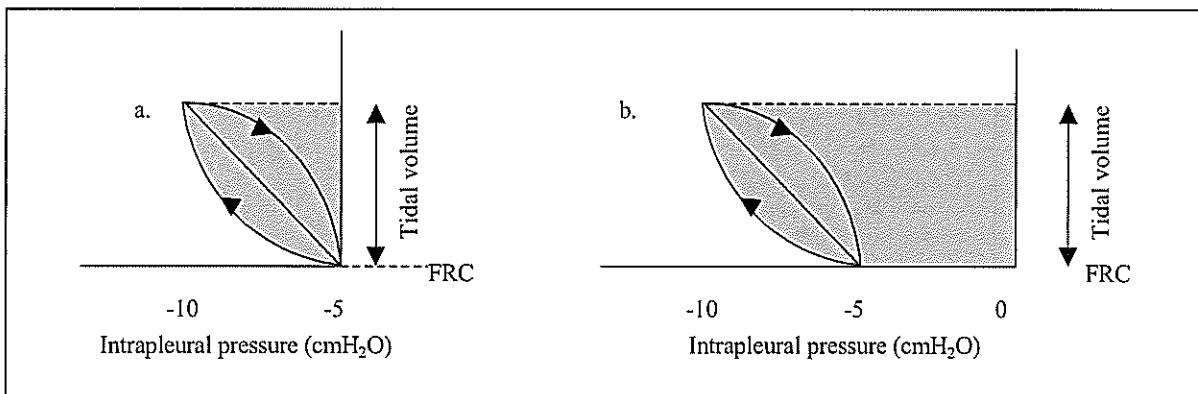

Answer:

Neither is strictly correct.

What are the limitations of each diagram?

1. In both cases there is an implication that IP pressure is uniform throughout the lung whereas it actually varies from apex to base.
2. The diagonal elastic compliance line is not strictly straight and is slightly curved even during a tidal breath.

3. a) Takes into account the passive work done by the chest wall but implies that it is a constant contribution throughout inspiration, whereas the contribution actually diminishes as the lung inflates
- 3 b) Does show that chest wall elasticity is contributing to lung inflation by holding the lung at a starting pressure of $-5 \text{ cm H}_2\text{O}$ and providing passive work during inflation.

A more correct illustration of the PV diagram (though not recommended for the vivas)

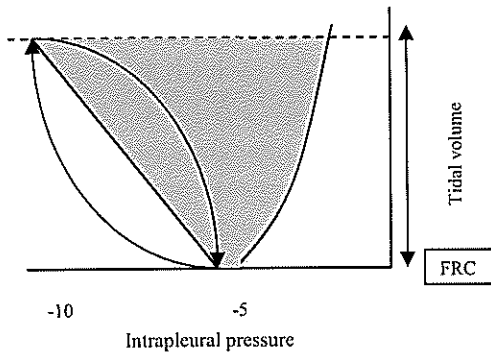

The Campbell diagram

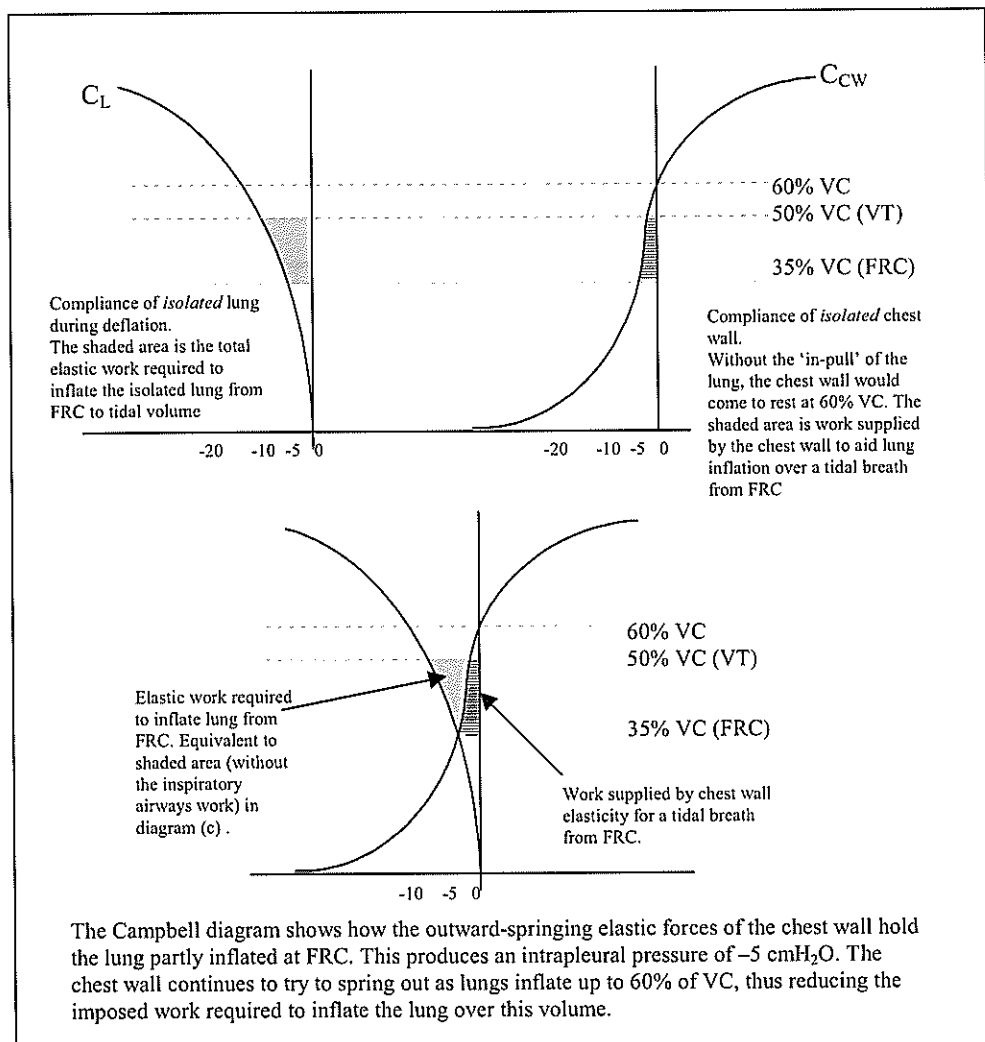

Relaxation pressure -volume curve

This illustrates the contribution of lung and chest wall compliance to total thoracic compliance (the latter being the *only* index which is actually measured in the experiment). Easily confused with the Campbell diagram in which the x axis is intrapleural pressure as opposed to airway (\cong alveolar pressure) in the relaxation pressure-volume curve.

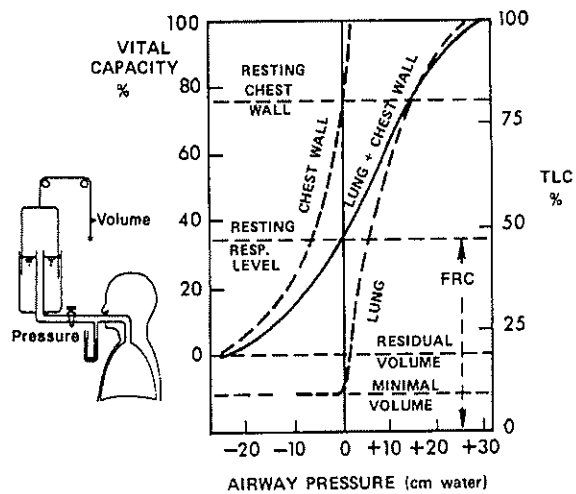
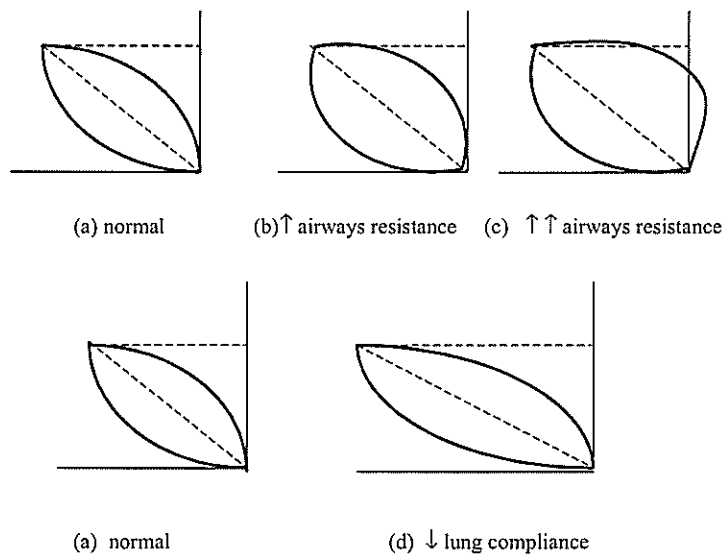

Figure 7.11. Relaxation pressure-volume curve of the lung and chest wall. The subject inspires (or expires) to a certain volume from the spirometer, the tap is closed, and he then relaxes his chest. The curve for lung + chest wall can be explained by the addition of the individual lung and chest wall curves. (Modified from H Rahn et al: *Am J Physiol* 146:161, 1946.)

Pressure - volume loop in lung disease

- 1) Effect of increased airway resistance on pressure-volume loop. In (c) the energy required to exhale is not covered by the stored potential energy and positive intrapleural pressure is required.
- 2) Effect of decreased lung compliance on the PV loop. Greater intrapleural pressure drop required to inflate stiff lungs to same volume. Therefore, \uparrow elastic (and total work) but stored potential energy is increased.



Influence of work on rate of breathing

In terms of rate and depth of breathing, for a given MV:

Elastic resistance is minimal with...	Rapid, shallow breaths
Air flow resistance is minimal...	Slow, deep breaths
Optimal frequency if elastic resistance ↑	Higher than normal
Optimal frequency if airways resistance ↑	Slower than normal

Practical example of PV loops: *Effect of pressure support on work of breathing*

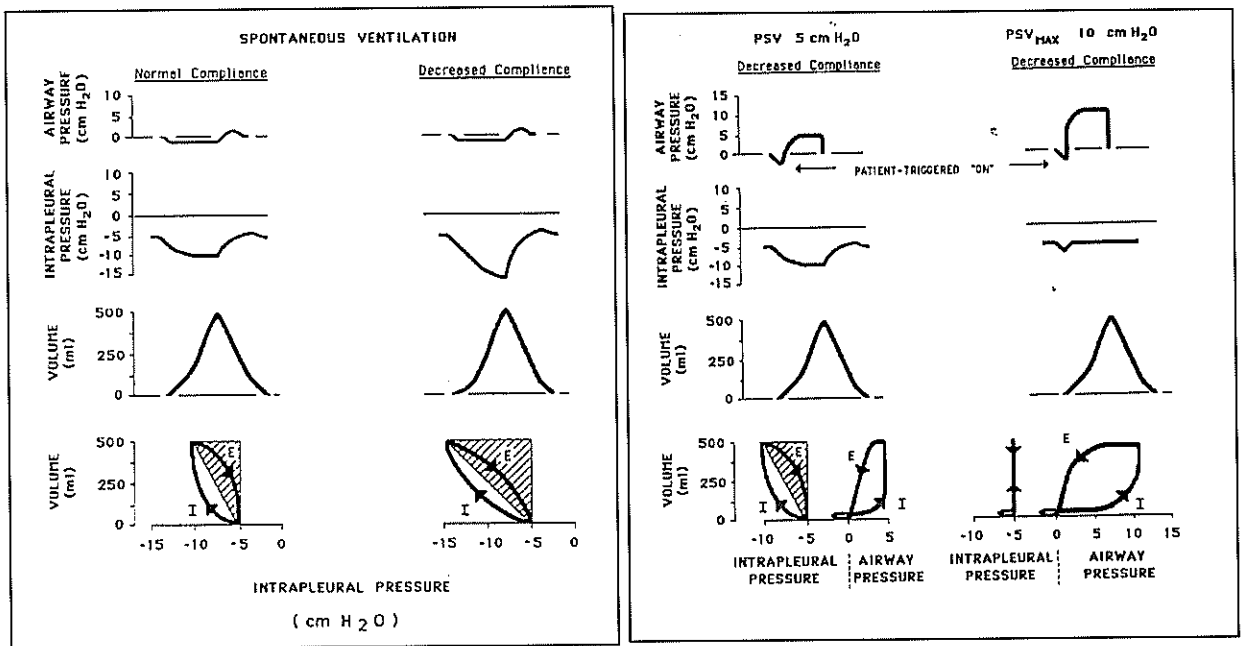

(a) Normal. 5 cm H₂O negative IP pressure change required to inflate lung to VT

(b) Reduced compliance. 10 cm H₂O negative IP pressure change required to inflate lung to VT

(c) Reduced compliance with 5 cm H₂O positive airways pressure support. Now only 5 cm H₂O negative IP pressure change required to inflate lung to VT

(d) Reduced compliance with 10 cm H₂O positive airways pressure support. Now, no negative IP pressure change required to inflate lung to VT. All work carried out by PS. PV loop is 'closed'

REFERENCES

- 1) Parbrook, Davis and Kenny.
- 2) Nunn
- 3) Banner et al. Components of the work of breathing and implications for monitoring ventilator dependent patients. Critical care medicine.1994.22:515-23
- 4) Banner et al. Patient and ventilator work of breathing and ventilator muscle loads at different levels of pressure support. Chest.1991;100:531-8.
- 5) Banner et al. Decreasing imposed work of breathing apparatus to zero using pressure support ventilation. Critical care medicine.1993;21:1333-8.
- 6) West

Measurement of lung volumes – excluding residual volume

1. Wet spirometer (Benedict Roth)

Bell in water bath moves with patient breathing. Movement recorded by pen. Measurements at ATPS will be ~10% less than at BTPS

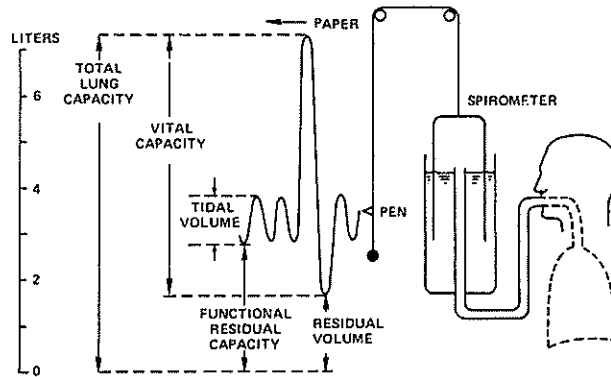

Lung volumes. From West JB. Respiratory physiology. The essentials. Lippincott Williams & Wilkins

2. Dry spirometer (eg Vitalograph)

Bellows expand and move stylus. Chart moves under stylus, so change in volume with time measured (eg FEV₁, FVC). Flow rates calculated from slope of curves. Graph scales are both ATPS and BTPS

Vitalograph traces in normal and diseased lungs

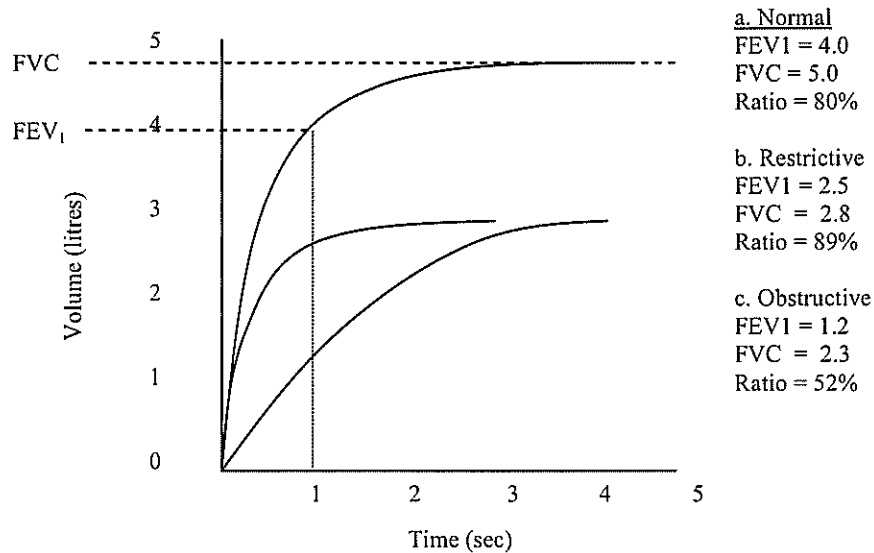

Other measurements

PEFR - tangent at beginning of expⁿ
 MMF - (max mid expiratory FR). Average between 25 and 75% of FVC.
 Removes effort dependent part of 1st 25% FVC.
 FEV₆ – FEV in 6 seconds. Easier and more precise end than ‘max’

3. Flow measurement x time

Pneumotachograph or Hot wire anemometer measures air flow but will measure volumes if flow is integrated with respect to time. Most common method in respiratory function laboratories. (See later)

4. Wright respirometer

Gas flows into the respirometer and rotates a vane that moves geared pointer. Mercury seal prevents water condensation corroding gears. Wright *electronic* respirometer: Disc rotated by vane has dark and bright segments so that movement can be detected by a photoelectric cell. More accurate than mechanical one because no drag from gears.

5. Others

a) Pneumography

First establish baseline relationship of change in circumference of both chest *and* abdomen to tidal volume as measured by spirometry. Subsequent changes continuously compared. Circumference measured using non-elastic tapes with bellows or strain gauge.

b) Respiratory inductance plethysmography

Two zig-zag coils carrying AC current encircle chest and abdomen. As patient breathes, the cross-sectional area of the circle changes and moderates the inductance between coils. Calibration required first using spirometry (*Respirace plus, NIMS Inc., Miami*)

c) Electrical impedance

Similar to that used to estimate cardiac output. Electrical impedance of thorax changes with the amount of air in it and, therefore, varies with respiration.

Measurement of lung volumes – including residual volume

1. Measurement of FRC using the body plethysmograph

Definition

A method by which changes in total lung volume can be quantified by the application of Boyle's Law.

Brief description

Patient sits inside a sealed box and pants around FRC through tubing connected to a pressure transducer, shutter and flow measuring device (not used here). Box may have opening to outside via a spirometer (variable volume / constant pressure method) or completely sealed (constant volume/ variable pressure method). The box pressure is also measured using as internal pressure transducer.

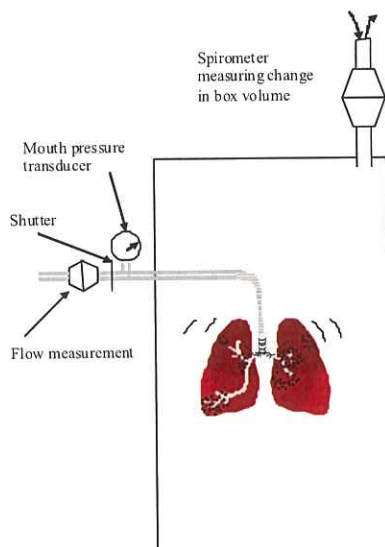

Constant pressure / variable volume box

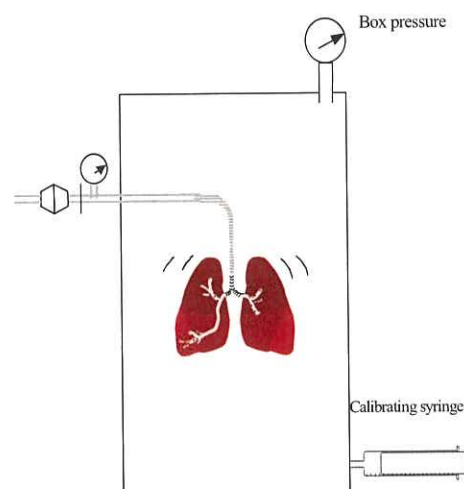

Constant volume / variable pressure box

How to answer a question on the measurement of FRC using the body plethysmograph

Step 1: Give concise definition of device: eg *A method by which change in lung volumes can be measured by the application of Boyle's Law*

Step 2: Brief description of apparatus (as above)

Step 3: The patient is asked to pant around FRC and the shutter is brought down distal to the pressure transducer. This seals the lung off, enclosing a fixed volume (FRC). $P_1 V_{1(\text{at FRC})} = P_2 V_{2(\text{at insp or exp pant})}$

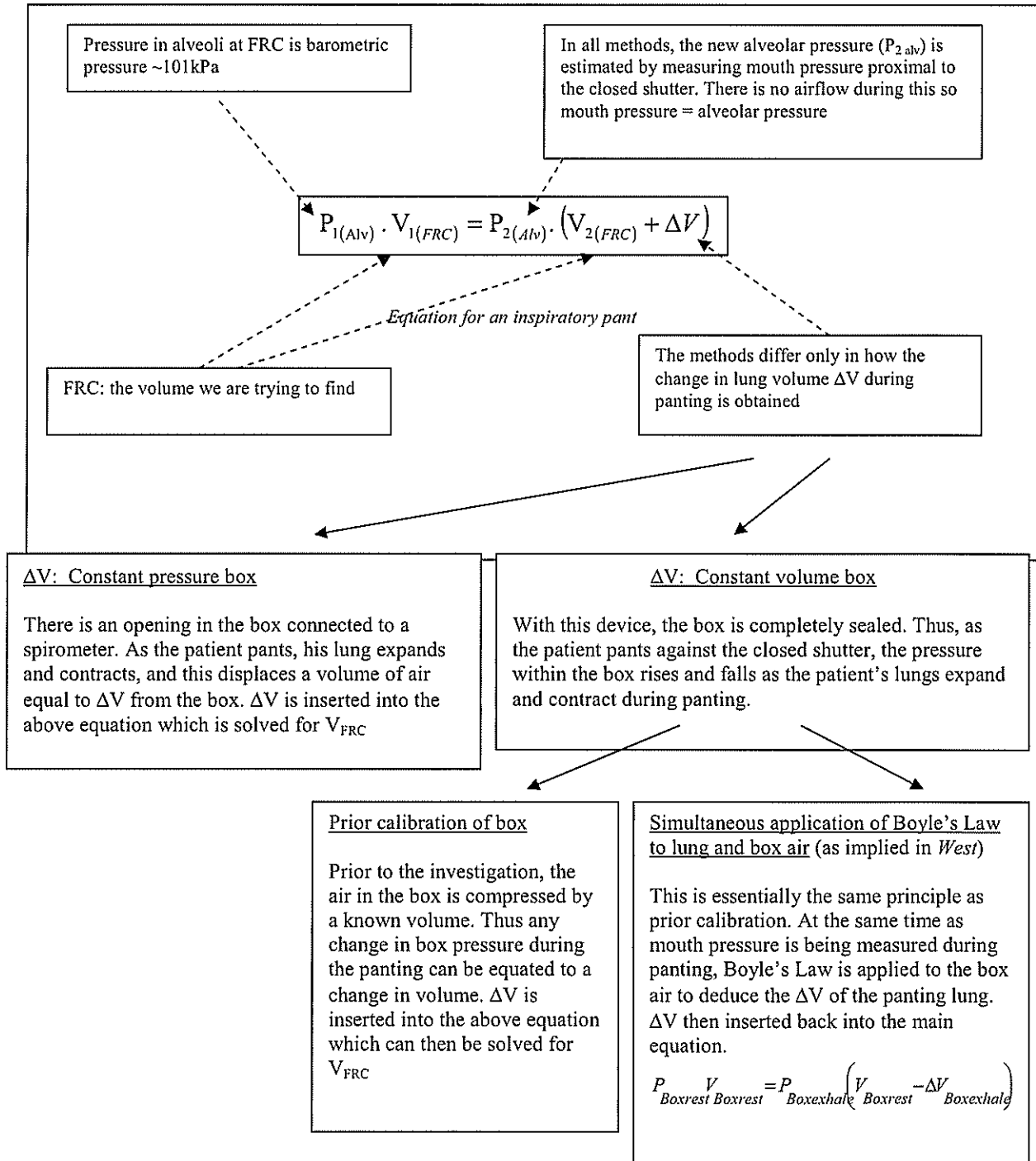

Points:

- a) The Constant volume method with prior box calibration is the commonly used method. This is the one you should describe for the exam.
- b) When you send someone for formal PFT's they will have their lung volumes measured by plethysmography not helium dilution. One reason is that plethysmography can be repeated several times within a few minutes. Dilutional methods cannot.
- c) Errors can arise in any of the methods if there is airways obstruction, as airway pressure \neq alveolar pressure.
- e) Everything within the visceral pleura is stretched out by the negative intrapleural pressure and will exhibit the same drop in pressure. Thus, another advantage of plethysmography over dilutional methods is that all thoracic gas is measured including bullae.
- f) When the shutter is closed, the patient is rarely at exactly FRC. The resulting measurement is, therefore, termed thoracic gas volume (Vtg) and is usually a little greater than FRC. FRC can be obtained by correcting during the calculation.

2. Helium dilution

Patient connected to a BR spirometer which is filled with a known concentration of helium. After about 3 min (healthy) the concentrations of helium in the lung and spirometer will be equal. If COPD, equilibration may take at least 11 min. The precision version will also have a CO₂ absorber in circuit as well as the delivery of basal O₂ requirement.

$$C_1 \cdot V_1 = C_2 (V_1 + V_2)$$

Where:

C₁ = [Helium] in spirometer at start.
V₁ = Volume of spirometer

C₂ = [Helium] in spirometer & patient after equilibⁿ.
V₂ = Volume of FRC

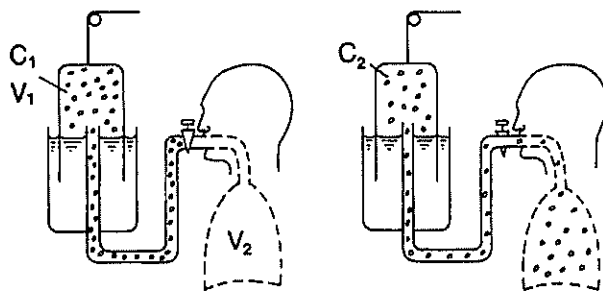

Before equilibration

After equilibration

$$C_1 \times V_1 = C_2 \times (V_1 + V_2)$$

Measurement of functional residual capacity by helium dilution. From West JB. Respiratory physiology. The essentials. Lippincott Williams & Wilkins

Why helium?

Helium is largely insoluble in blood.

Advantage of body plethysmography

Body plethysmography measurements include gas trapped behind closed airways whereas helium dilution method only measures gas in communication with the mouth.

3. Nitrogen dilution / washout

This is largely research or historical. Not a practical method for day to day PFTs.

Patient breathes air, then 100 % oxygen. All expired gas is collected into Douglas bag via non-rebreathing valve. Gas collected until all nitrogen is

washed out ~ 7 mins. As lung initially contained 80% nitrogen, the FRC volume must equal approximately 100/80 times the volume of nitrogen in bag.

Equation: $V1 \times 80 = (V1 \times C3) + (V2 \times C2)$

Where:

80 = [N2] in lung at start.

V1 = Lung volume

V2 = Total volume exhaled into bag during washout.

C2 = [N2] of exhaled gas.

C3 = [N2] in lung at end. (Will be close to zero).

NB: Some accounts state that, because $C3 \cong 0$, $(V1 \times C3)$ can be disregarded in the calculation

4) Radiological imaging

X-ray: qualitative rather than quantitative

CT: 3-D reconstruction enables total and regional quantification

Anatomical dead space

Single breath N₂ washout
(Fowler's method)

Single inspiration to VC of 100% oxygen → nitrogen concentration and expired volume measured at lips during single expired breath. Vertical line drawn such that area A = area B on up-slope to plateau. Dead space is volume expired up to that point.

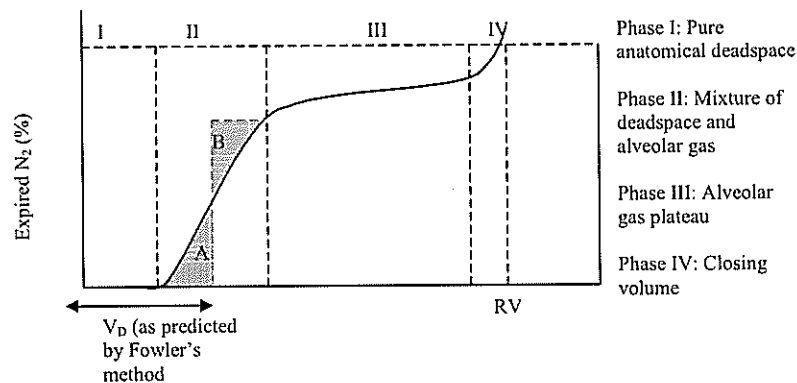

Bohr's method

See elsewhere

$$\frac{V_D}{V_T} = \frac{F_{ACO_2} - F_{ECO_2}}{F_{ACO_2}}$$

Closing volume and closing capacity

Spirometry, with closing capacity and closing volume superimposed for comparison

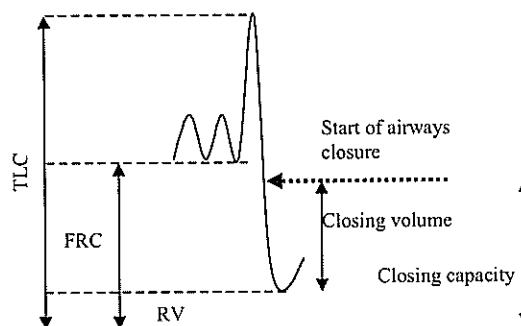

1. Single breath N₂ washout for closing volume

Technique

Vital capacity breath (ie from RV) of 100% oxygen → dependant alveoli have greatest expansion and receive most O₂. Apical areas have distended alveoli and receive relatively less O₂. N₂ concentration and expired volume measured:

Phases (see diagram in Fowler's method):

- I) Pure oxygen from upper airways
- II) Rapid rise in N₂ concentration as anatomic dead space washed out by alveolar gas
- III) Alveolar gas. 'Flattish' or gently sloping if there is non-uniform ventilation of lung units
- IV) Small airways begin to close off. This happens in dependant areas first, leaving the apical areas, which have the least diluted N₂, to contribute proportionately more to the expirate → N₂ concentration rises. CV is from this point to the end of expiration.

2. Xenon or Argon bolus

Patient again takes VC breath (ie from RV). The tracer this time is Xe or Argon as opposed to 100 % O₂ and is given as a *bolus* at the *beginning* of inspiration, as opposed to *throughout* inspiration. Because the small airways in the dependant areas are closed at the time the bolus is inhaled, the Xe goes preferentially to the *apices*. During expiration, the Xe *tracer* is measured and, because it has higher concentration in the apices, will again cause a concentration rise in Phase IV when dependant areas close off.

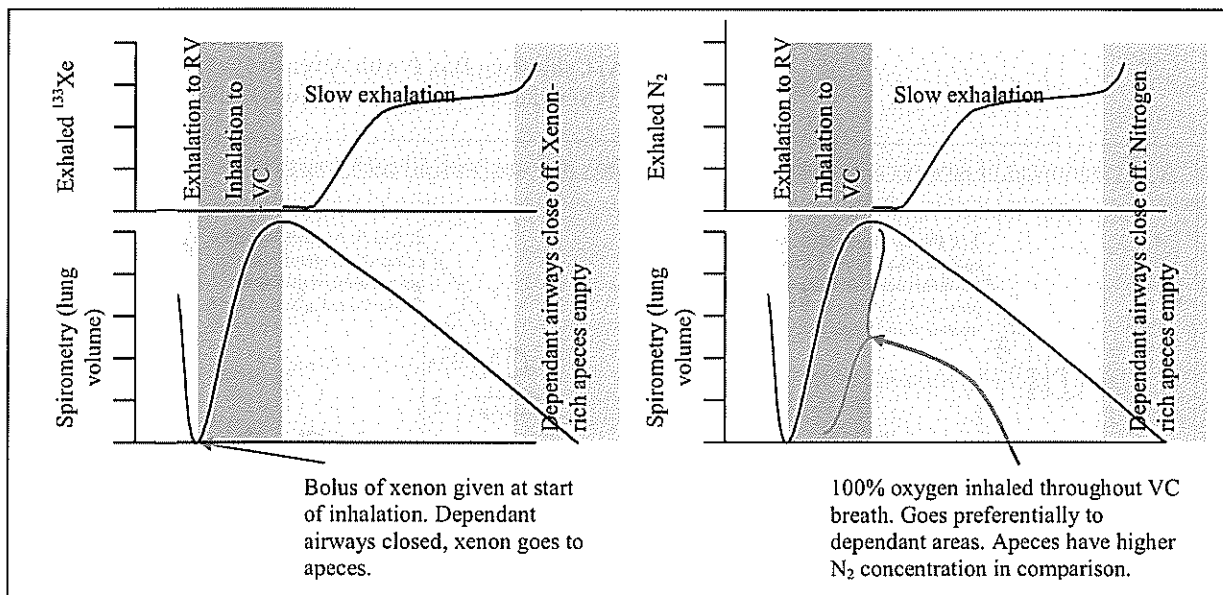

A comparison of closing volume measurements using (left) a xenon bolus and (right) a vital capacity breath of 100% oxygen. Note that in both cases the exhalation trace takes an upswing at phase IV, despite the fact that the measured gas is the tracer (¹³³Xe) in the first example and the resident gas (N₂) in the second. The key to this apparent paradox is that ¹³³Xe is given as a *bolus* at the *start* of inspiration when dependant areas are closed, whereas, when O₂ is used, it is given throughout inhalation and will distribute predominantly to the better-ventilated, dependant areas. (See Gibson CJ. Clinical tests of respiratory function.)

Measurement of airways resistance

Resistance in terms of flow and pressure	$R = \frac{\text{Mouth pressure} - \text{alveolar pressure}(\text{cmH}_2\text{O})}{\text{Flow}(\text{l}\cdot\text{sec}^{-1})}$
Methods	Constant volume body plethysmograph (standard method) Others Constant pressure plethysmograph Oscillation technique Subtraction technique
Methods to detect changes in airway resistance	PEFR, MEFR Flow volume loops

Constant volume plethysmograph:

Method	Flows are measured with the patient breathing through a pneumotachograph. As the patient breathes, the change in alveolar pressure causes a change in lung volume and this results in a rise and fall in box pressure. Alveolar pressure can be derived from the change in box pressure in two different ways: A) Calibrating Box P with Alveolar P (Standard method) B) Simultaneous Boyle's equations (As described in West)
--------	--

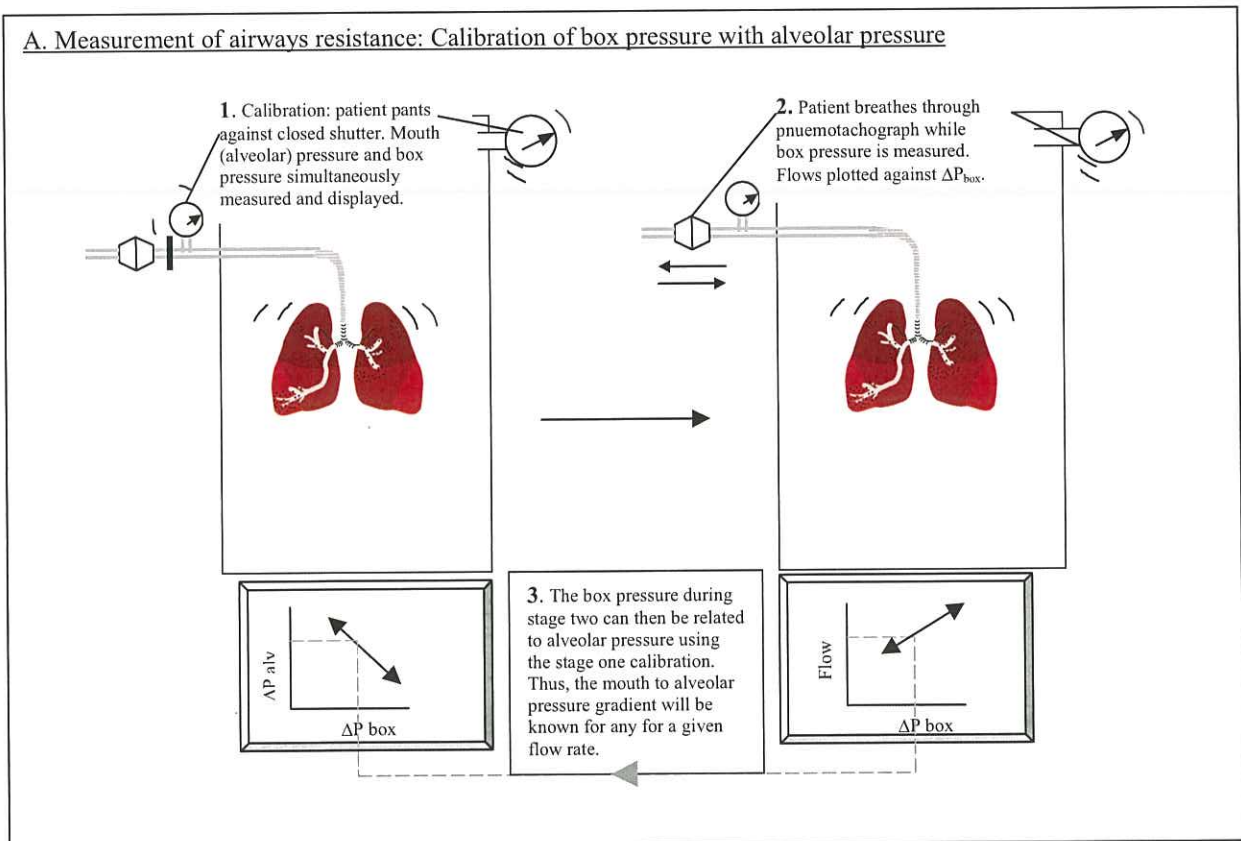

Problem

In airways disease the pressure measured at the mouth when shutter closed \neq alveolar pressure.

Other methods

Interrupter technique

Airflow repeatedly interrupted for brief periods, during which mouth pressure is measured as an index of alveolar pressure

Subtraction technique

During quiet breathing, flows are measured (pneumotachograph) simultaneously with transpulmonary pressures (oesophageal balloon). Transpulmonary pressure during breathing is the sum of that required to overcome airways resistance and that required to overcome lung elastance. The latter can be estimated from either a static or dynamic compliance study, and subtracted from transpulmonary pressure to give the airways pressure component.

Oscillation technique

Sinusoidal oscillations (tidal volume of 30 – 50 ml; frequency of 3 – 10 Hz.) are superimposed on top of normal tidal breathing. Airflow, transpulmonary pressure (oesophageal balloon) and mouth pressure are measured. Pressure changes are due to impedance caused by airflow resistance, inertia and elastic forces. The latter two forces are the *reactance* of the system and are closely related to the frequency of the oscillations. At the oscillatory resonant frequency, the impedance caused by inertia and elastic forces cancels each other out leaving that due to airflow resistance.

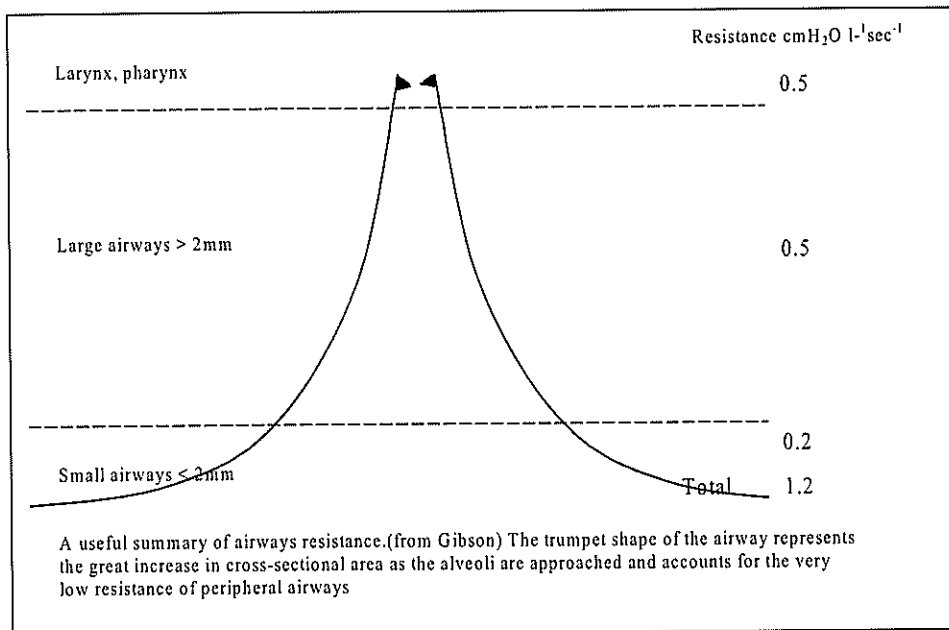

Lung compliance

Measurements

PV curves plotted by measuring change in lung volume with change in alveolar-pleural pressure gradient.

Method

Oesophageal balloon + spirometer or plethysmograph

What is the difference between static and dynamic compliance?

Static compliance is measured during conditions of no airflow and dynamic compliance is measured during normal quiet breathing. The two are the same or very similar in normal individuals but may differ if there is airways disease.

i) Static compliance

Breathe out from TLC in *steps* and measure mouth and oesophageal pressure at each step. You can, thus, estimate the pressure across the lung, lung recoil pressure ($P_{alv} - P_{pl}$) Lung allowed to stabilise for a few seconds after each step to make sure the IP press reflects the forces of elastic recoil of lung and not those associated with airflow. Compliance is measured over the tidal volume by approximating the curve to a straight line over that volume range.

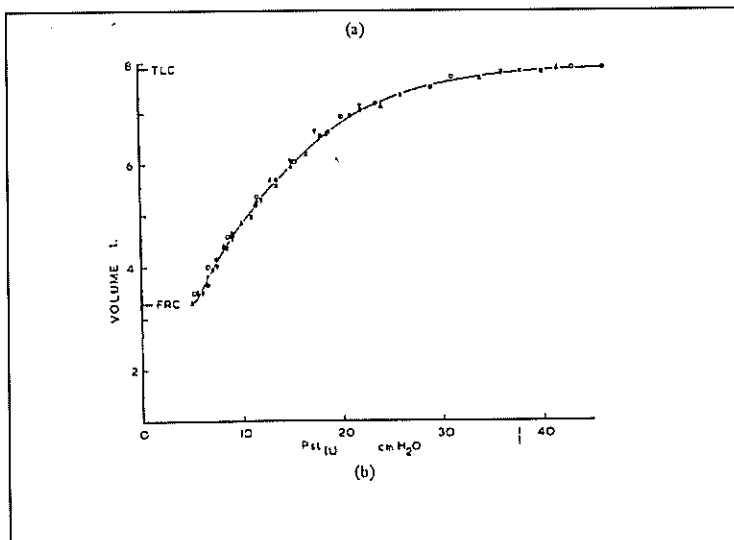

Diagram from Gibson showing construction of static lung compliance diagram by incremental deflation from TLC. The x axis ($P_{st L}$) is the static pressure gradient across the lung, measured while relaxing against a closed airway (ie $P_{mouth} - P_{pl}$ which is = $P_{alv} - P_{pl}$ when there is no airflow)

ii) Dynamic compliance

Measured during quiet breathing. The points of presumed no-flow at the I-E and E-I change over are joined and the slope is the compliance. If airways resistance is low, alveoli reach full pressure equilibration with the mouth pressure at end inspiration. In lung disease, alveolar filling may not be complete within the inspiratory period and flow may still be occurring between units when flow at the mouth has ceased (Pendelluft effect). When this occurs, dynamic compliance is lower than static compliance. The discrepancy increases at higher frequencies and is termed frequency dependant compliance.

'Application' of this inaccuracy

The variation of compliance with frequency can be used as an indication of small airways disease. Disease of the small, peripheral airways may not be picked up in studies of total airways resistance.

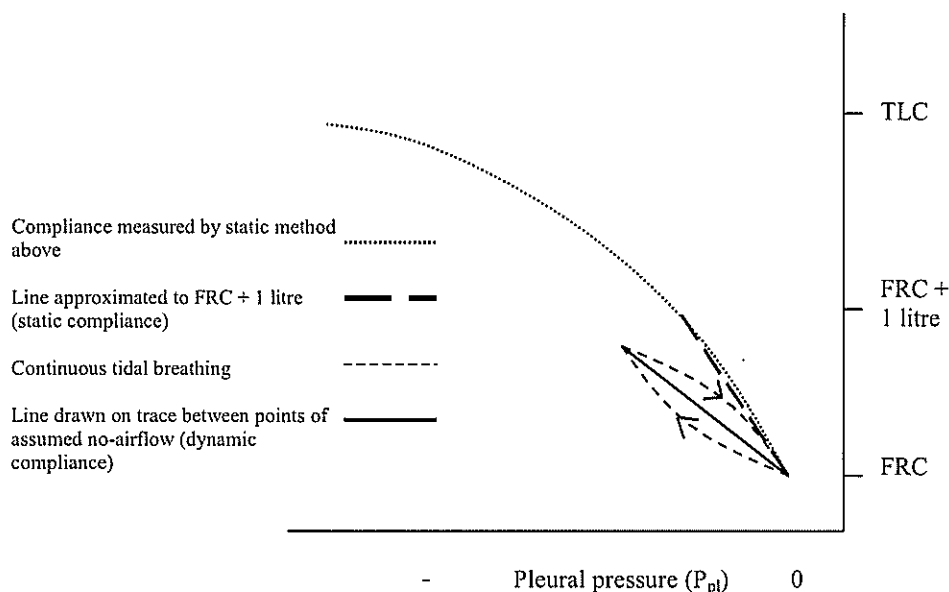

Comparison of static and dynamic compliance methods in patient with small airways disease. Lung compliance appears less in dynamic study because slow lung units are still filling / emptying when airflow is *assumed* to be zero. Thus, for a given pressure drop, inflation of lung is less. Note, to aid understanding, both traces have been drawn on an x-axis of intrapleural pressure.

Measurement of diffusing capacity / transfer factor.

What is meant by diffusing capacity (D_L)?	The rate of uptake of a gas (usually CO) by the whole lung per unit pressure of CO.
Units	mls CO min ⁻¹ mmHg ⁻¹
Normal value	25 ml. min ⁻¹ mmHg ⁻¹
Is this analogous to resistance?	No, the opposite, conductance.
What other term is often used and why?	Transfer factor (T_LCO) Because D_L does not solely depend on diffusion across the lung membrane.

What is the path taken by an O₂ molecule from lung to Hb?

- 1) Diffusion across membrane
 - Membrane thickness
 - Membrane area
 - MW and solubility of gas in membrane
- 2) Travel through blood
 - Plasma
 - RBC membrane
 - RBC interior
- 3) Chemical combination with Hb

Diffusion of gas across membrane

$$\dot{V}_{gas} = \frac{A}{T} D \cdot (P_{alv} - P_{cap})$$

(D is specific for the a gas and determined by its MW solubility in membrane)

For an average lung, A, T and D can be incorporated into the more generalised entity D_L to give:

$$D_L = \frac{\dot{V}_{gas}}{(P_{alv} - P_{cap})}$$

Thus, for CO, we would expect 25ml/min/mmHg to be transferred in a normal lung. (A and T approximated for a normal lung. If less than 25 ml/min, we assume there may be a problem with the A and/or T, but there are also factors 2) and 3) above to consider).

Why is carbon monoxide used ?

So that the amount of CO getting into the blood is limited by the diffusion properties of the blood-gas barrier and not by the amount of blood available to take up the CO.

Why?

The affinity of Hb for CO is so high that, as CO passes from the alveoli into the blood, the partial pressure of CO in the pulmonary capillary blood is effectively zero. As the RBC's pass along the capillaries, therefore, no back pressure develops, the concentration gradient is maintained and the gas continues to move across the alveolar wall. The amount passing through is thus limited by the diffusing properties of the B/G barrier rather than the amount of blood available.

Thus, for CO

$$D_L = \frac{\dot{V}_{co}}{P_{alv_{co}}}$$

Measurement of transfer factor (D_L)

Principle:

You measure the rate of uptake of CO from the lung

i) Single breath method

Single vital capacity inspiration 0.3% CO in 10% helium → breath held for 10 seconds to allow full distribution → difference between alveolar [CO] at the start and end of breath hold is measured and a rate of change is calculated.

Basic calculation requires

Alveolar [CO]
Expired [CO] after 10 secs is directly measured after dead-space discarded
→ the rate of change of [CO] per litre is calculated from an exponential equation to give the Diffusion coefficient (K_{CO}) which has the units ml.min⁻¹.mmHg.l⁻¹.
→ K_{CO} is multiplied by the alveolar volume to give D_L.

$$D_L = K_{CO} \times \text{Alveolar volume}$$

Why is helium inhaled as well?

1. We need to know the starting alveolar [CO] but this will be less than the inspired [CO] because of dilution by the residential alveolar gases. Helium is inhaled with the CO and, because, it is not absorbed, the ratio of expired to inspired helium gives you the degree of dilution by the other alveolar gases. This allows the alveolar [CO] to be calculated from the inspired [CO].
2. The alveolar volume is calculated by helium dilution (NB. CH₄ can be used instead of He.)

Lung volume influences on DL_{CO}

DL_{CO} depends on the alveolar volume available for gas transfer and is usually measured at full inspiration.

Decreased DL_{CO}

Alveolar membrane disease (eg fibrosing alveolitis)
 Low alveolar volume (restrictive lung disease)
 Anaemia
 Ventilation maldistribution

Increased DL_{CO}

Polycythaemia
 Congestive cardiac failure

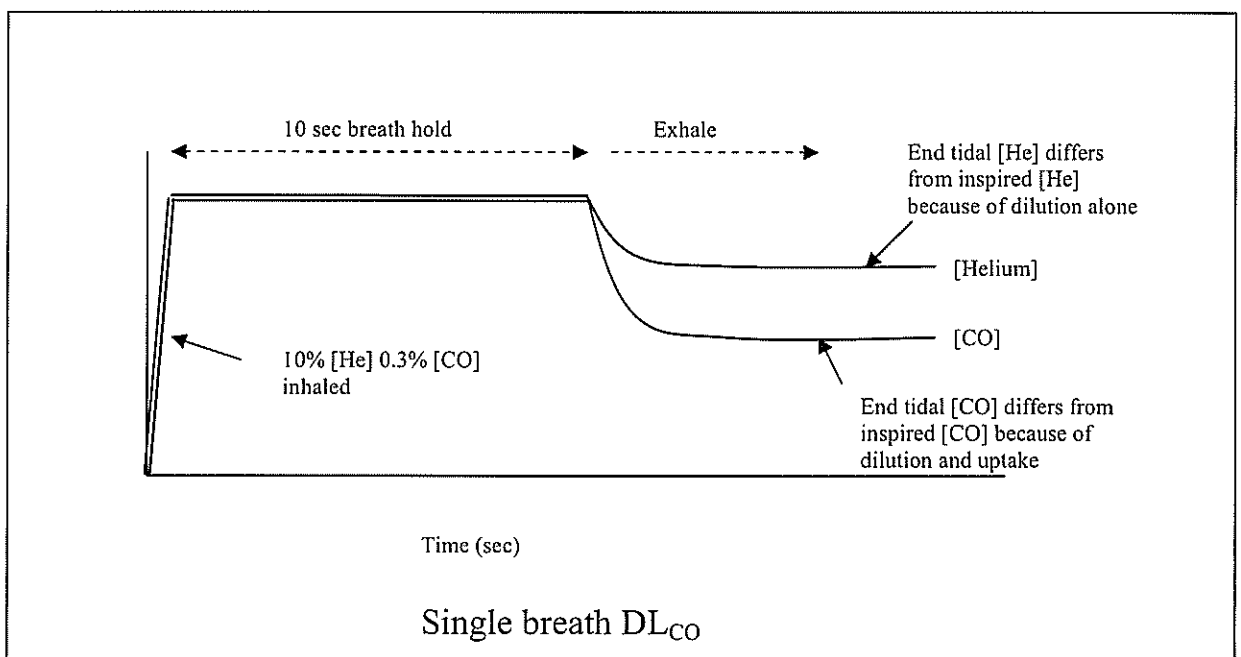

ii) Steady state method

Low concentration of CO breathed for ~ 60 secs to produce a steady state alveolar P_{co}. End tidal gas analysed to determine rate of disappearance of CO. PA_{co} calculated from a form of the alveolar air equation.

Can we separate diffusion from reaction rate with haemoglobin?

Equation for full resistance

$$\frac{1}{D_L} = \frac{1}{D_M} + \frac{1}{\theta \cdot V_c}$$

θ is specific gas uptake capacity per unit blood.

V_c is capillary blood volume
 D_M is the component dependant on diffusion

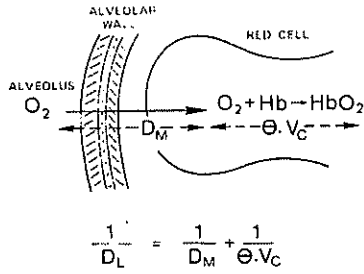

Diffusing capacity of the lung (D_L) has two components, that due to diffusion (D_M) and that caused by the time taken for O_2 to combine with haemoglobin (θV_c). From West JB. Respiratory physiology. The essentials. Lippincott, Williams and Wilkins.

How do you separate out the components?

CO and O_2 compete for same binding sites on Hb so θ depends on local PO_2 . The values for θ at different PO_2 values are available from tables.

$1/D_L$ measured at two different PO_2 and plotted against the appropriate values for $1/\theta$ obtained from tables. A line is drawn between the points and has a basic formula of $y = mx + c$
 $1/D_M$ is the y value at the intercept (where $1/\theta$ is zero) and $1/V_c$ is the slope of the line. See below.

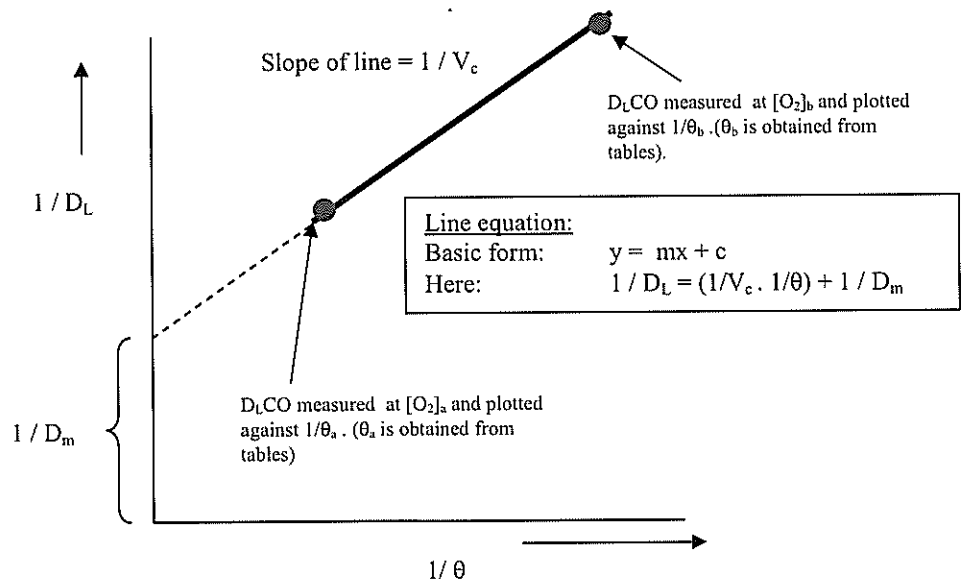

Flow studies

Maximum expiratory flow- volume curve (MEFV)

Plots the maximum flows against lung volume during a single forced expiratory breath from TLC. Flow rises rapidly to peak and then declines to a portion of the curve where flow is independent of effort.

Measurement

Pneumotachograph + plethysmograph or
Pneumotachograph + expired volume

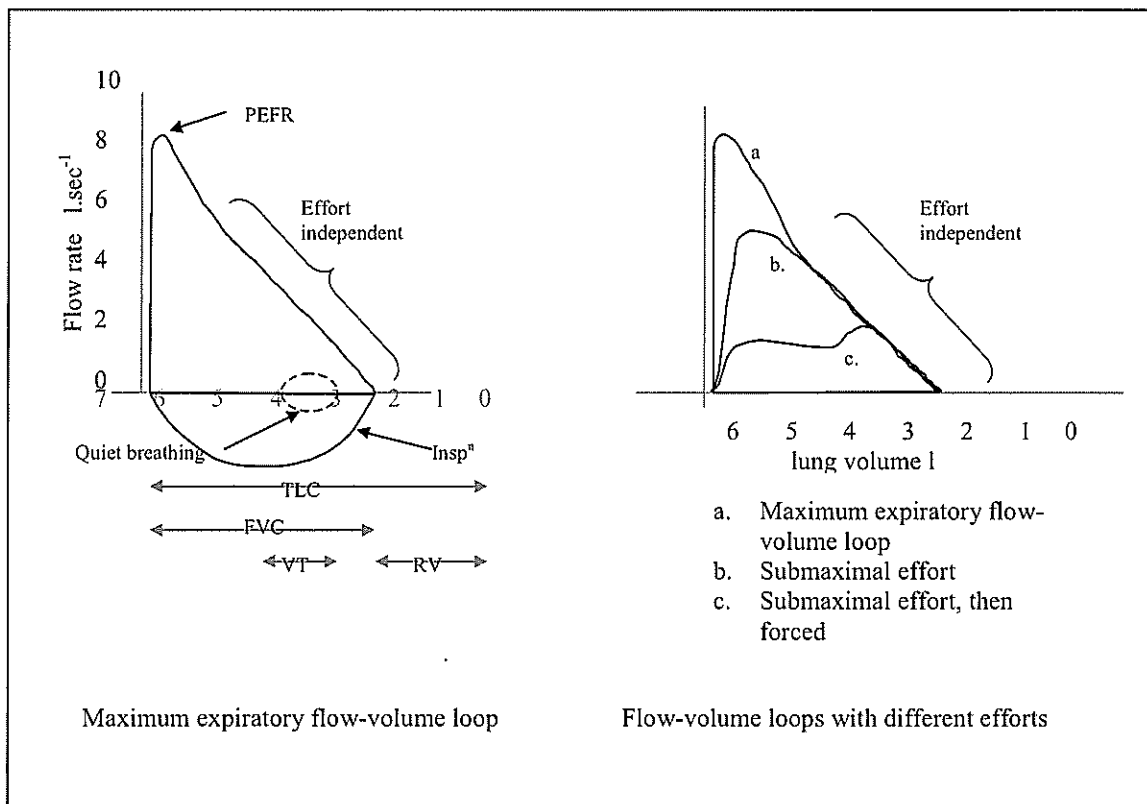

Why does flow rate become independent of effort?

Dynamic compression of the airways. During quiet exhalation, gases are driven down the airways by a positive alveolar pressure caused by lung recoil. The airways are held open by the distending forces of the negative intrapleural pressure. The latter holds true when small expiratory efforts are made as well. During forced expiratory efforts above a certain level, however, although the alveolar driving pressure is increased, the downstream airways are compressed by the same force, preventing an increase in airflow.

EPP theory

Equal pressure points. These are the points on the airway tree where the intrabronchial pressure equals the extrabronchial pressure. Intrabronchial pressure falls from alveolus to mouth. The alveolar pressure is the sum of that produced from lung recoil and positive intrapleural pressure of forced expiration. The EPP occurs where there has been dissipation of pressure along the airway of the

magnitude of that caused by lung recoil. In other words, the pressure drop along the segment upstream from the EPP is equal to lung recoil pressure.

Do EPP's change during forced expiration?

During forced expiration at high lung volumes (> 50% VC), the EPP's lie fairly far downstream in the large segmental and lobar airways. The structural rigidity of these airways prevents collapse and flow limitation. However, as the lung volume falls, the lung recoil component of the intrabronchial pressure also falls and the EPP's move upstream to the smaller airways.

What is the relevance of the upstream segment?

Flow rates during later forced expiration are mainly determined by flows and resistance in the upstream segment. These flow rates fall as the lung deflates because of a proportional reduction in lung recoil and an increase in airways resistance caused by progressive narrowing during lung deflation.

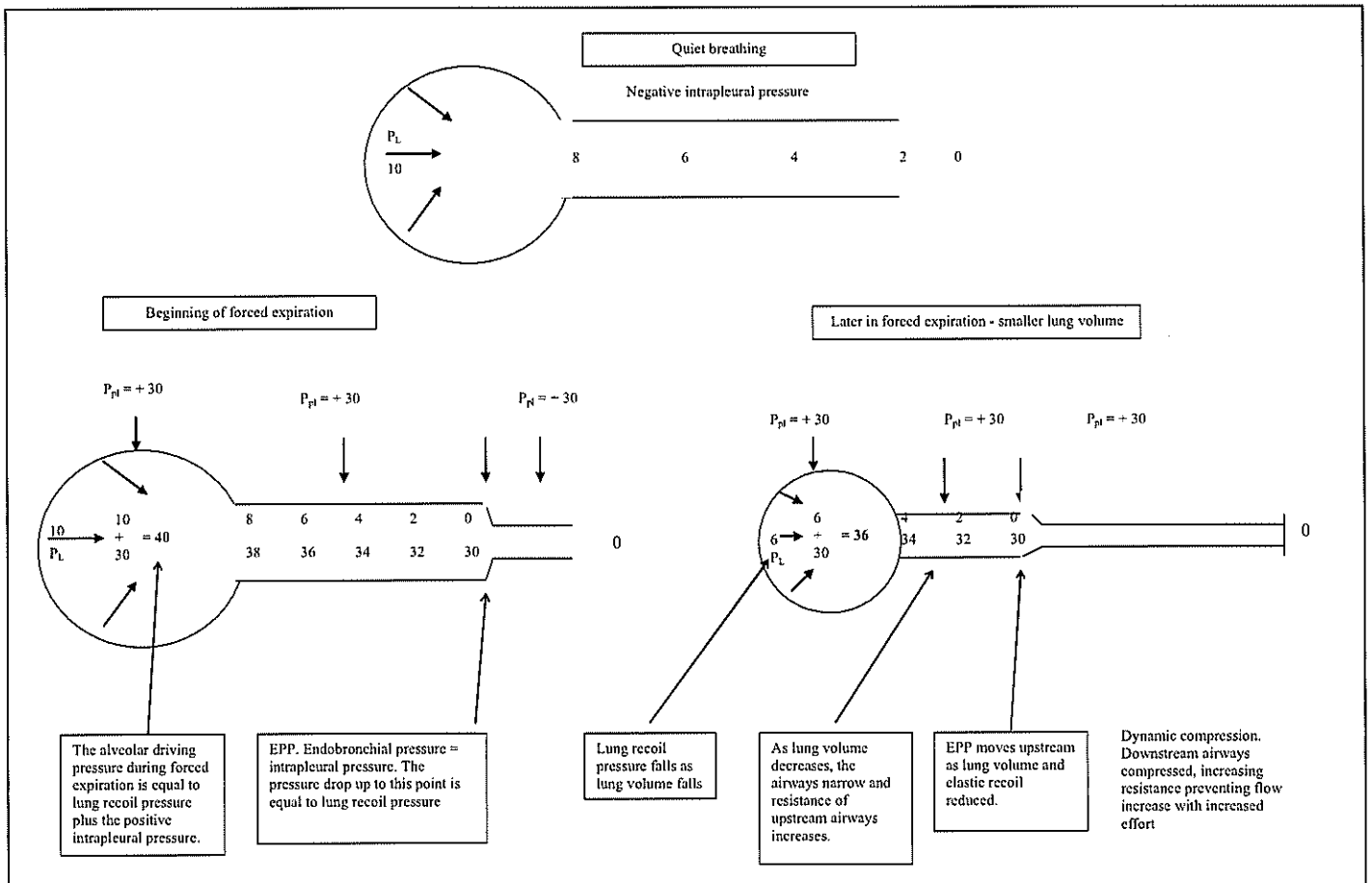

Partial flow-volume curves

Initiation of study from lower lung volumes.

Use

The calibre of the airways and the bronchomotor tone are dependant on the immediately preceding breathing pattern
 eg A full inspiration minimises lung recoil and bronchomotor tone with opposite effects on flow during the following forced expiration. Initiation from lower lung volumes maintains bronchomotor tone better and allows the influence of drugs on tone to be better assessed.

Flow volume loops in disease

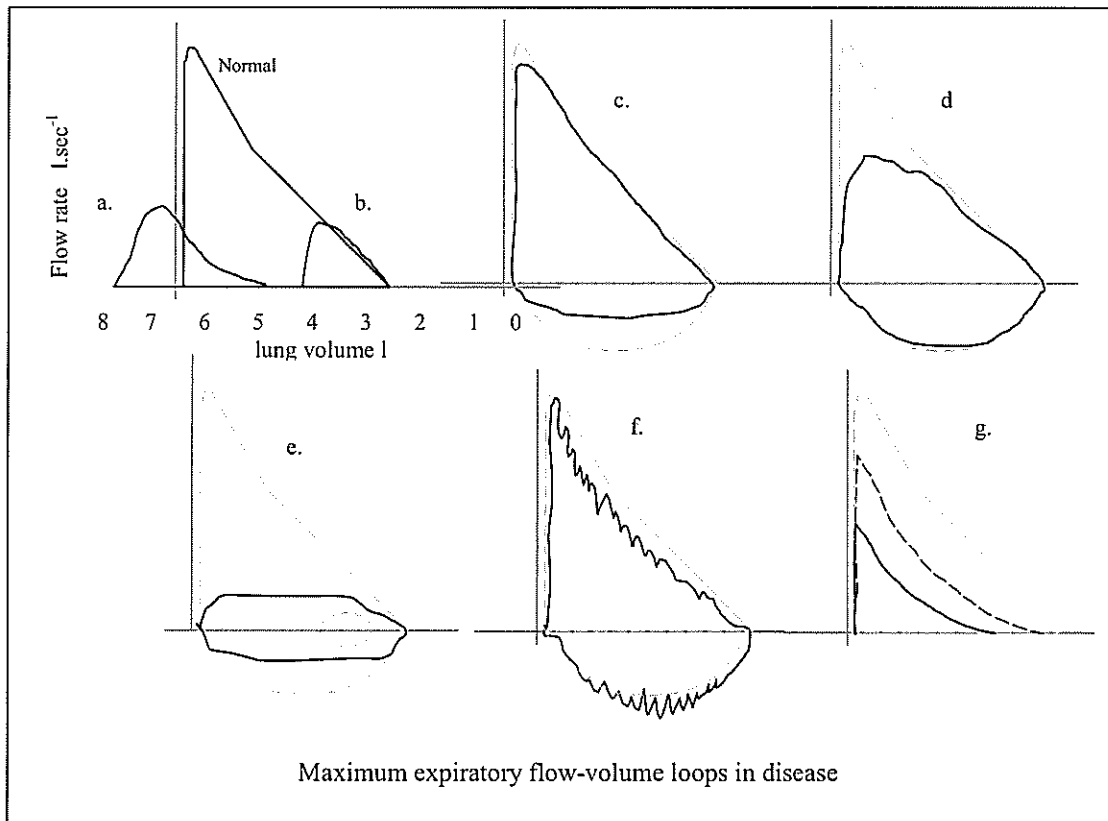

- | | | | |
|----|--|---|---|
| a. | Obstructive lung disease with air trapping | eg. Emphysema | Concave (scooped out) appearance. ↑ TLC, ↑RV, ↓ FVC, ↓PEFR. |
| b. | Restrictive lung disease | eg. Pulmonary fibrosis | Convex, ↓ TLC, ↓ FVC, ↓ PEFR |
| c. | Variable extrathoracic obstruction | eg. Laryngeal tumour, | Airway narrows on inspiration → ↓ flows on inspiration |
| d. | Variable intrathoracic | eg tracheal tumour | Airway compressed on expiration → ↓ expiratory flow |
| e. | Fixed extrathoracic obstruction | eg Laryngeal tumour | Curve flattened in both phases |
| f. | Saw-tooth pattern of obstructive sleep | Unstable upper airway: OSA, bulbar weakness | |
| g. | Reversible airflow obstruction | Bronchospasm | |

NB: a) and b) are illustrated with absolute lung volumes including RV on the x axis. When spirometry is carried out in the clinic this is not the case as only the exhaled volume (forced vital capacity) can be measured. All traces will therefore start together at zero on the x axis as per c to f.

Isovolume pressure flow curves (IVPF)

Used to examine the effect of effort on flow (ie *dynamic compression of the airways*) at different lung volumes.

How are they formed?

Patient makes a series of expiratory manoeuvres from full inflation, each manoeuvre having a different degree of effort. The measurements made are flow rate, expired volume and intrapleural pressure (oesophageal balloon). A particular lung volume (eg 50% VC) is then selected and the pressure and flow data obtained at this volume are picked out from each effort test. A plot can then be made of the flows associated with the different IP pressures (different efforts) at the selected volume. Note: IP pressure is sometimes converted to alveolar pressure by adding lung recoil pressure.

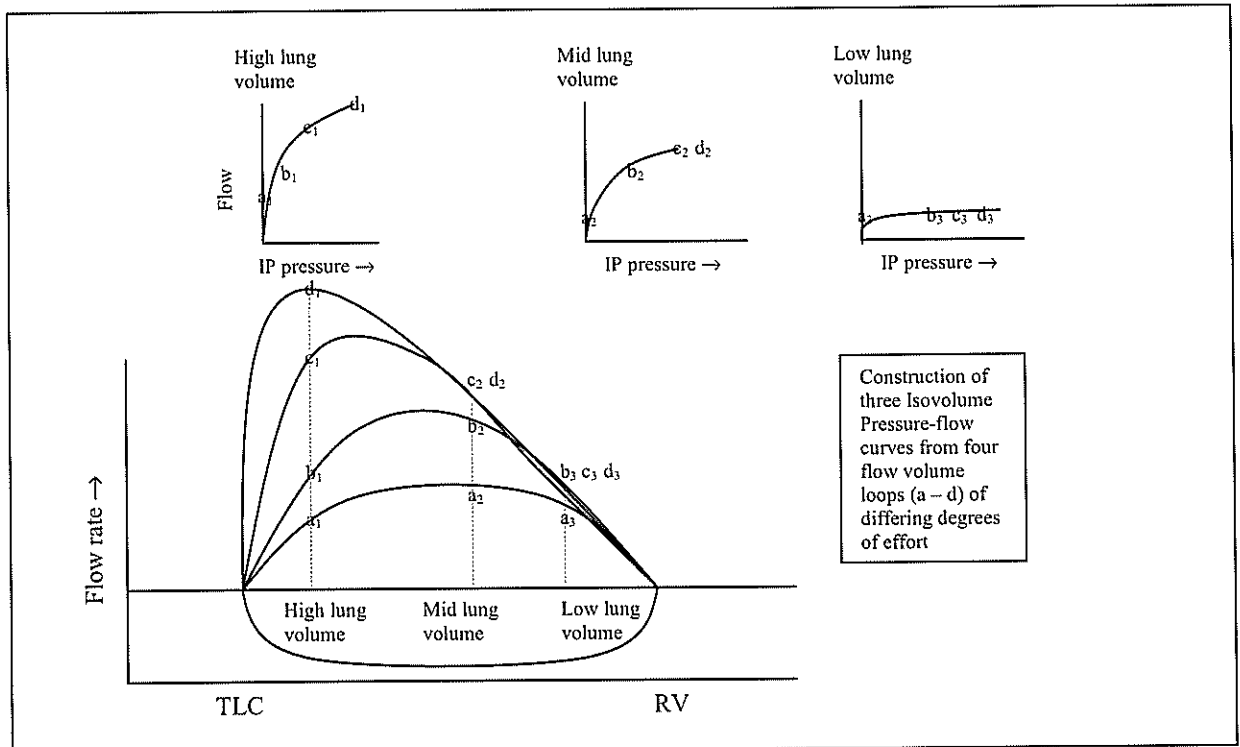
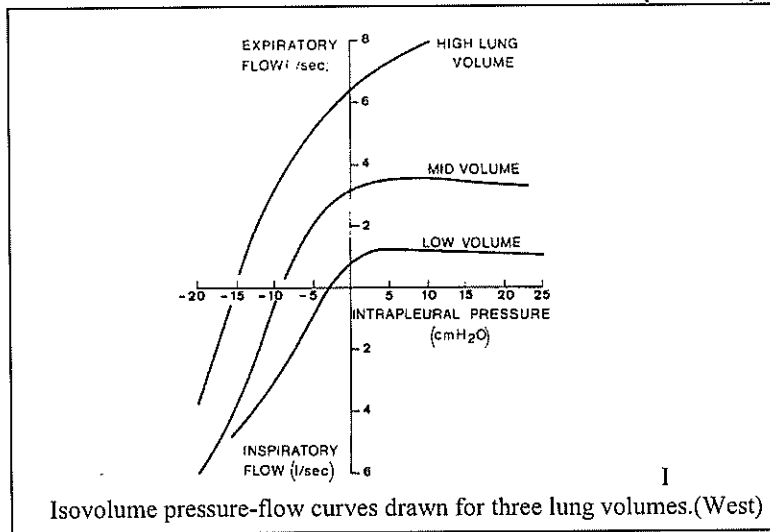

Other assessments of flow

i. Maximum breathing capacity

Maximum minute volume of ventilation which can be maintained for 15 seconds.

Normal value

~ 170 l/min

ii. Spirometry (eg Vitalograph or integration of flow with time using pneumotachograph)

i) FEV1 / VC or FVC

Simplest and most practical guide to presence of airways obstruction. (See Vitalograph)

Opinions differ as to whether FVC or VC (largest voluntary expiration followed by deepest inspiration.) should be used. The VC is a more relaxed and larger measurement. Best way is to take the larger of the two whichever it is.

iii. Maximum mid-expiratory flow (MMF)

Mean maximum flow between 25 and 75 % FVC. Also termed forced expiratory flow between 25 and 75% (FEF₂₅₋₇₅).

Measurement

Obtained from graph of volume against time.

Advantage

Avoids the more effort dependant first quarter of the FVC.

MEASUREMENT OF GAS FLOWS

<i>Measurement of gas flows</i>		
Electrical resistance	Hot wire anemometer Strain gauge	Cooling of hot wire Flow bends flexible 'lollipop' that compresses strain gauge. Sieman's Servo"
Pressure drop	Pneumotachograph Variable orifice flowmeter ("Rotameter") Venturi Orifice	Flow calculated from pressure drop across known resistance Gravity acting on bobbin balanced by upward force of flow. In contrast to Pneumotach., the pressure across the bobbin is constant and resistance varies. Pressure drop at venturi $\propto \text{Flow}^2$ Pressure drop through orifice $\propto \text{Flow}^2$
Other mechanical	Pitot tube (Vitalograph)	Small tube points directly into airflow Slope of trace = flow rate
Vanes	Wright electronic spirometer and peak flow meter Dry gas meter Fluidic flow	Flow moves vanes 'Volumetric turnstile'. Domestic and industrial use Vanes induce swirls which rotate single vane
Ultrasound		Velocity increases with gas flow Flow impacts obstruction causing vortices

Hot Wire Anemometer

(aka Electronic mass flow measurement)

Heated platinum or tungsten wire, placed in gas pathway is cooled by the gas flow which decreases electrical resistance of wire. Degree of cooling depends on flow rate. (and specific heat capacity of gas). Corrections made during processing for the latter. Change in resistance is measured using the Wheatstone Bridge.

Notes a) To compensate for variations in gas temperature, a second wire is kept at the ambient gas temperature but sheltered from the flow. b) A correcting current may be applied to keep the wire at constant resistance or temperature and the bridge balanced. The required current is measured to determine flow rate.

Pneumotachograph

Gauze (Lilly) or bundle of parallel tubes (Fleisch) causes a known resistance to flow and pressure to drop across them. This is measured by a differential pressure transducer.

Designed to produce laminar flow so that resistance is constant over a wide range of flows.

Laminar flow is viscosity dependant therefore has to be calibrated for specific gas.

Gases heated to prevent condensation which would encourage turbulence

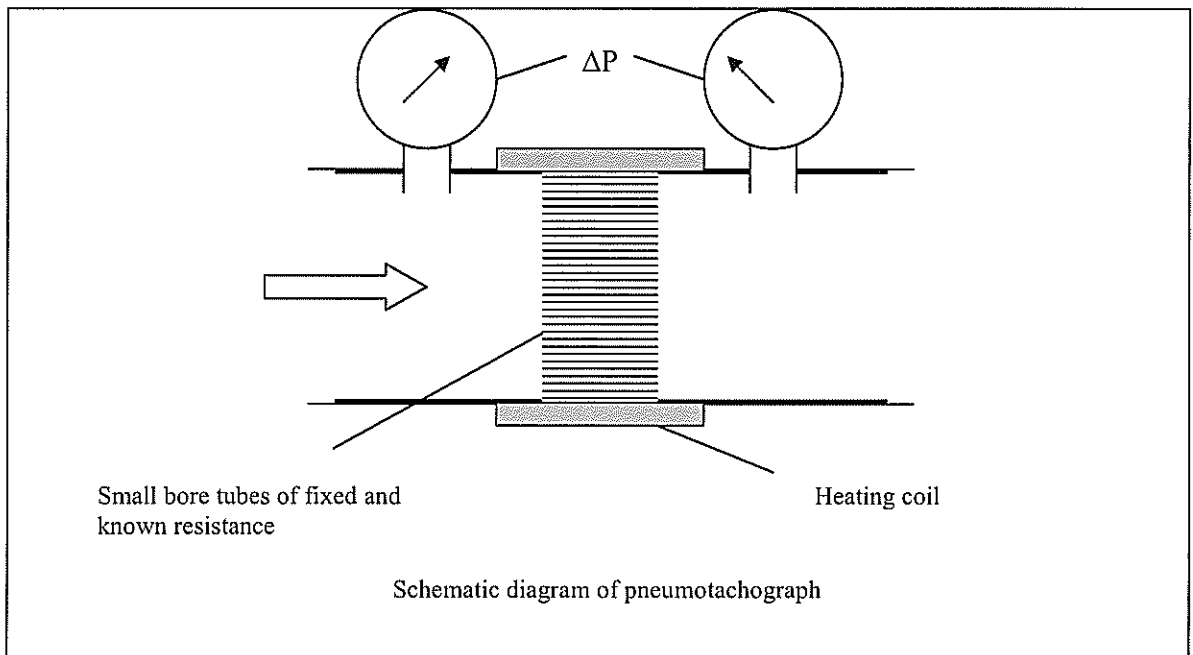

Orificial or tube

Gases forced through a tube or orifice. Pressure drop measured, possibly by a Bourdon gauge. If path is a tube the pressure drop is proportional to flow. If an orifice, it is proportional to the flow squared.

Venturi

Measurement of pressure drop at venturi narrowing. ΔP roughly proportional to square of flow.

Pitot tube

A small tube that points directly into the air flow. If combined with one that points downstream, bidirectional flow is measured. The tube contains air and the pressure required to bring the air to rest can be measured using transducers. This pressure is termed the stagnation pressure. May be combined with pneumotachographs to improve accuracy. Common method of measuring airspeed in aircraft

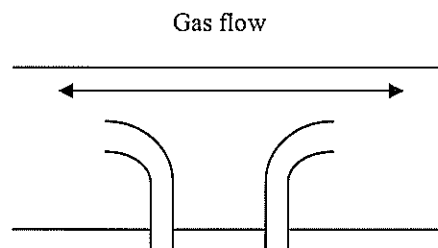

Two pitot tubes for measuring bidirectional gas flow

Variable orifice flowmeter (Rotameter)

Bobbin supported in tapered tube by the gas flow. For the bobbin to be stationary, the force of gravity downward on the bobbin must be exactly balanced by the upward force exerted by the flowing gas. For the bobbin to come to a stationary position after an alteration of flow, the pressure drop across the bobbin must be constant no matter what the flow is. This is achieved by increasing the radius of the tube with higher flows so that the increase in flow is offset by a reduction in resistance.

ie Pressure = Flow x Resistance; $\Delta P = Q \eta / 8 \pi r^4$ so $\Delta P \propto Q / r^4$

Importance of viscosity & density

At low flows, flow is laminar and therefore viscosity dependant. At high flows, however, the space around the bobbin becomes larger, more orificial, and turbulent flow occurs. In these circumstances density becomes important.

Hyperbaric conditions:

\uparrow density gases \rightarrow \uparrow upward force and pressure for a given flow \rightarrow bobbin sits higher up tube for given flow.
Thus, flowmeter overreads at hyperbaric conditions.

Back pressure

i) If \uparrow back pressure (eg caused by Manley ventilator or nebuliser) the actual flow to the patient will be greater than that indicated by the flowmeter.

$$F_A = F_I \sqrt{P_F / P_B}$$

Where:

F_A = Actual flow

F_I = Indicated flow

P_F = Flowmeter pressure

P_B = Atmospheric pressure

ii) \uparrow backpressure reduces flow across needle valve

Effect of temperature

As density and viscosity vary with temperature so does the performance of the flowmeters. They are calibrated for a specific temperature - 20°

Safety features

Knobs: Knobs colour coded

Oxygen knob set forward

Oxygen knob individual shape and diameter

Antihypoxia interlinking of oxygen and N2O.

Bobbin: Bobbin rotates so it is seen to be 'free'

A dot on the bobbin highlights its spin

Antistatic casing to prevent sticking

Spring at top of CO2 keeps bobbin visible

Flowmeters: Non-interchangeable

Additional low flow flowmeter

Leaks: To prevent excessive loss of oxygen if leak in middle flowmeter or middle of block:

i) USA - oxygen flowmeter far right

ii) Others - oxygen channelled out past the N2O opening

Wright's electronic spirometer

Gas flows into device to strike a rotatory vane. As the vane turns the movement is sensed by a photodetector and processed into volume and flow rate. The Drager volumeter is a similar device.

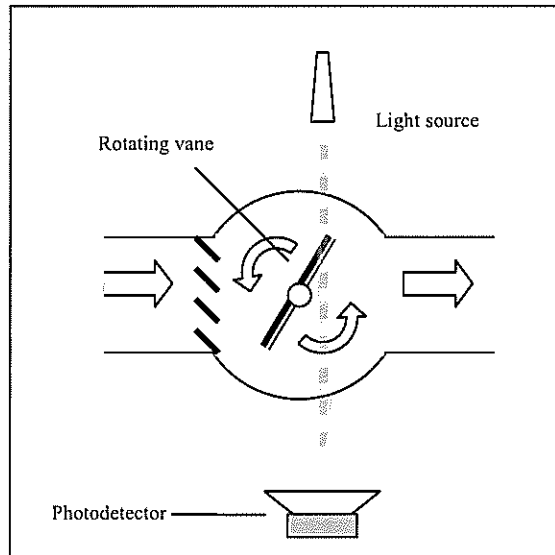

Wright peak flowmeter

A variation on the Wright's spirometer. The WPF is a variable orifice method. Expired gases move vane which is opposed by the constant force of a spring. As the vane moves, a slot is steadily uncovered to allow more and more gas to escape. This allows a maximum flow to be reached as indicated by a pointer.

Fluidic flowmeter

Swirls induced by fixed vanes which causes rotation of single vane → detected optically (Ohmeda)

Ultrasonic flowmeter

i) Pulse of ultrasound into gas flow. Sound detected downstream and transit time measured. The velocity of the sound is increased by gas flowing in the same direction.

ii) Vortex shedding: Laminar gas flow hits obstruction and sheds vortices → detected by ultrasound.

Flow measurement in modern anaesthetic machines

Most commonly use differential pressure method, either across a constriction or openings. HWA also mentioned.

Spirometry

A small tube is placed in line at the patient end of the breathing circuit. The pressure drop across the tube is measured

Delivered gas flows

1. Hot wire anemometry or/and

2. Pressure drop measured at two openings mounted in series within flow. In current Ohmeda machines, the sensors are found in the cassette to which the circle is connected
3. Lollipop-type strain gauges

LED flowmeters

A small side tube splits from the main gas flow distal to the needle valve. This leads to a constriction and a differential pressure sensor.

BIBLIOGRAPHY

- 1) West JB. Respiratory physiology-the essentials. 3rd edition
- 2) Nunn's applied respiratory physiology.4th edition
- 3) Gibson GJ. Clinical tests of respiratory function. 2nd edition. Chapman and Hall Medical. London.
- 4) Ruppel GE. Manual of pulmonary function testing. 6th edition Mosby. St Louis.
- 4) Parbrook, Davis and Parbrook. Basic physics and measurement in anaesthesia
- 5) Sykes et al. Principles of measurement and monitoring in anaesthesia and intensive care
- 6) Ward. Anaesthetic equipment
- 7) Scurr and Feldman. Scientific foundations. Anaesthesia
- 8) www.frca.co.uk

FLUID FLOW

Fluids

Fluids are things that flow. May be liquids or gases

Laminar flow

Characteristics

Fluid moves steadily in the same direction, without eddies.

Can be likened to concentric cylinders of fluid sliding over each other.

Velocity greatest at the centre and falls to zero at the wall giving a cone shaped front to the flow.

LAMINAR FLOW

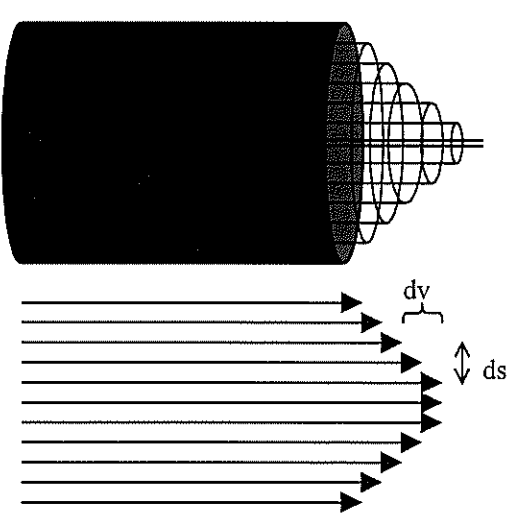

Laminar flow down a smooth tube resembles concentric layers sliding over each other

The *shear rate* is the velocity gradient over a 'sideways' distance
 $\text{Shear rate} = dv / ds$

The force between layers that causes the velocity gradient is the *shear stress*.
 $\text{Shear stress} = F / A$

Velocities of concentric layers in laminar flow. Fastest in the middle. Slowest on outside.

Relationship between laminar flow, pressure and resistance

$$\text{Flow} = \frac{\Delta \text{Pressure}}{\text{Resistance}}$$

Note: In laminar flow, resistance is constant for a given fluid in a given tube and does not vary with flow.

Hagen-Poiseuille equation

$$\text{Flow} = \frac{\pi \Delta P r^4}{8 l \eta} \quad \text{or}$$

$$Flow = \frac{\pi \Delta P d^4}{128 l \eta}$$

Thus, factors affecting laminar flow

Flow $\propto \Delta P$
 Flow $\propto r^4$
 Flow $\propto 1/\text{length}$
 Flow $\propto 1/\text{viscosity } (\eta)$
 (Flow increases with warming because $\uparrow \text{Temp} \rightarrow \downarrow \eta$)

Does this apply to all fluids

Only Newtonian fluids (see below)

Viscosity

Brief definition of viscosity?

The property of a fluid which causes it to resist flow.
 An expression of the frictional forces acting between layers as a fluid flows along a tube.

What is its full name?

The coefficient of dynamic viscosity (η)

Any other types of viscosity?

Kinematic viscosity (ν) (See later)

What is dynamic viscosity (η)?

In laminar flow, random lateral movement of particles causes friction between the sliding layers (*viscous drag*), impeding sliding and causing the velocity of layers to fall (dv) across the tube over a 'sideways' distance (ds). This results in a lateral velocity gradient (dv/ds), the *shear rate*.

The frictional force applied over an area on the surface of a layer (F/A) that produces this gradient is called the *shear stress*. This force is proportional to the viscosity of the fluid and the velocity gradient.

Thus, a substance with high viscosity has large frictional forces per given velocity gradient.

$$F = Area \cdot \eta \cdot \frac{dv}{ds} \qquad \eta = \frac{F}{A} \frac{ds}{dv}$$

Where: η is the coefficient of dynamic viscosity; A is the contact area between the layers

Units

CGS units: dyn.sec.cm⁻² (most commonly used) or Poise
 S.I units: Pascal. second or N.sec.m⁻² (rarely used)

What is a Newtonian fluid?

A fluid in which the dynamic viscosity is not affected by the flow rate itself. To get one layer to slide over another twice as fast you have to double the force required to overcome resistance. The shear stress is proportional to the relative motion of the layers and thus dynamic viscosity is constant.

What is a non-Newtonian fluid?

A fluid in which the relationship between shear stress and shear rate is more complex and non constant.

Is blood Newtonian or non-Newtonian?

Strictly speaking, non-Newtonian. This is particularly seen at low flow rates where RBC aggregation occurs. At higher flow rates this factor loses importance and it can be regarded as near Newtonian.

Effect of warming on viscosity and density

Liquid	↓ viscosity	↓ density
Gas	↑ viscosity	↓ density

How is viscosity measured?

Viscometer. A cone shaped bobbin sits in spinning sample of fluid and is dragged round by viscous drag from the fluid. The bobbin's movement is displayed on a scale.

Turbulent flow

Characteristics

Occurs in situations of high flow, particularly if there are irregularities in the tube.
Fluid swirls and eddies.
Velocity no longer maximal in middle of tube. Large scale lateral movements flatten-out flow profile.
Driving pressure more related to density than viscosity
Various algebraic relationships exist for particular fluids, tubes and orifices. Most are approximations fitted to empirical data.

Relationship between flow, pressure resistance?

As with laminar flow, an increase in driving pressure will increase and flow, but the relationship is non-linear and may be complex depending on the tube shape. At it's simplest, for a tube without branches, the driving pressure is proportional to the square of the flow. The resistance to flow in a given tube is thus no longer constant.

Flow through an orifice

Flow through tube which has length less than radius. Flow is always partly turbulent.

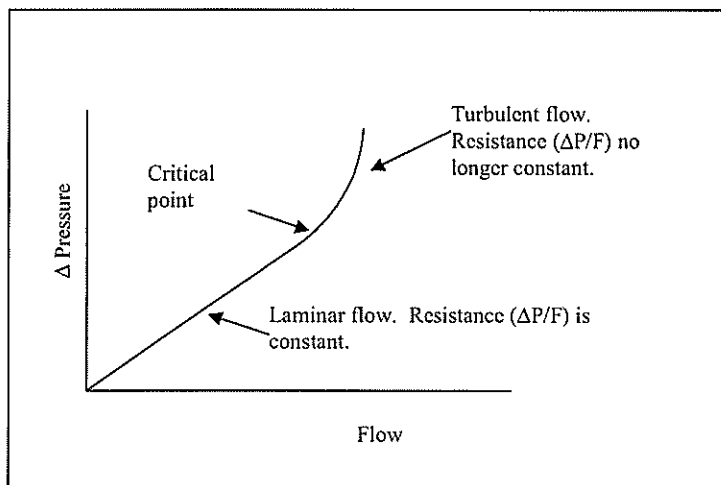

Figure above. The effect of flow on resistance in laminar and turbulent flow. (Simple, smooth-sided tube)

Table right.
Comparison of driving pressure in laminar and turbulent conditions. (Simple, smooth-sided tube):

<u>LAMINAR FLOW</u>	<u>TURBULENT FLOW</u>
$\Delta P \propto \text{Flow}$	$\Delta P \propto \text{Flow}^2$
$\Delta P \propto \text{Length}$	$\Delta P \propto \text{Length}$
$\Delta P \propto \text{Viscosity}$	$\Delta P \propto \text{Density}$
$\Delta P \propto 1 / r^4$	$\Delta P \propto 1 / r^5 *$

* This, exponent from Nunn is not quite compatible with Parbrook which states that, when the radius of the tube decreases, for a given flow, the required increase in ΔP is slightly greater in turbulent than laminar flow. It is probably safest to say that it is not expressible as a simple power of the radius.

Fanning equation

Relates pressure drop to flow in turbulent conditions

$$\Delta P = \frac{\dot{V}^2 f l}{4\pi^2 r^5}$$

(Where f is a *friction factor* dependent on the roughness of the tube and Reynolds number.)

Prediction of onset of turbulent flow – Reynold’s number

What is Reynolds number?

A formula which predicts whether flow is likely to be laminar or turbulent. It is a ratio of inertial forces to frictional forces. The greater the inertial forces relative to the frictional, the more likely is turbulence.

Reynolds number = $\frac{v \rho d}{\eta}$

v = average velocity
 d = diameter
 ρ = density
 η = dynamic viscosity

Re number for cylindrical, smooth tube
 Re number for irregular tube

laminar < 2000 ; turbulent > 2000 *
 Depends on exact situation but turbulence may occur with a Re number of as little as 300

* This figures is from references 1, 2, and 3. Nunn uses a range of 1000 to 1500, between which both types of flow exist and, above and below which, there is entirely turbulent and laminar flow respectively.

Role of viscosity and density in turbulence?

A highly viscous fluid tends to reduce turbulence by dampening down inertial disturbances, while low viscosity promotes turbulence. The inertial forces ($v\rho$) of swirls and eddies tend to persist when density increases as more energy is retained within the eddies. Thus, high density promotes turbulence.

What is kinematic viscosity (ν)?
 Kinematic viscosity is an adjustment of dynamic viscosity to take into account density in the prediction of turbulence. The dynamic viscosity is divided by the density. Most commonly used when talking about fluid flow under the influence of gravity. Reynold’s number may be re-written thus:

Reynold's number = $\frac{v.d}{\nu}$ Formula and units kinematic viscosity $\nu = \frac{\eta}{\rho}$ Units: $m^2.s^{-1}$ or $cm^2.s^{-1}$ (stokes)

Thus, a fluid with moderate dynamic viscosity but high density would behave as a lower viscosity fluid with a greater likelihood of turbulence. This would be born out in the kinematic viscosity value.

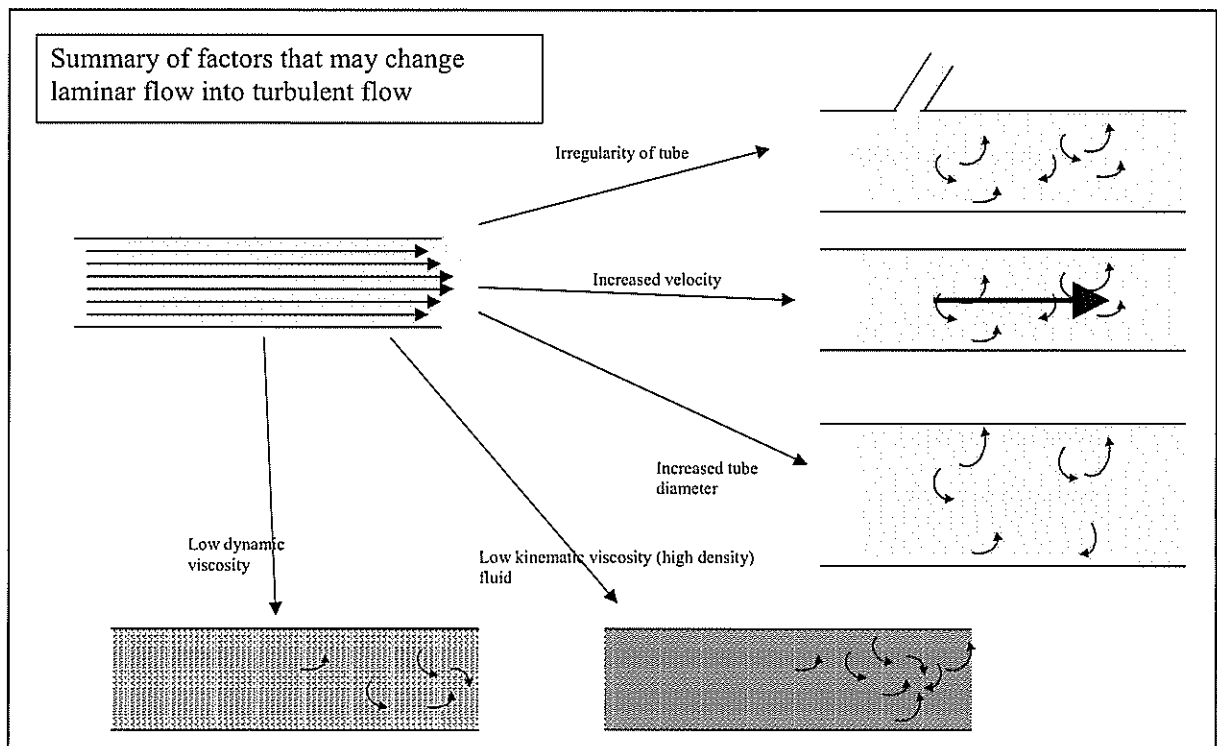

Clinical aspects

1) Variation in flow and resistance with different gas mixtures

Oxygen in Helium vs Oxygen in Air

Low density of He → reduces the incidence of turbulent flow in resp disorders → reduces resistance and work of breathing. Helium mixtures no advantage in laminar flow conditions because viscosities of inhaled gases all similar.

Oxygen and N₂O vs Oxygen in Air

N₂O is less viscous than N₂ → ↓ ΔP during laminar flow but, because the ρ of N₂O is higher, there is increased likelihood of turbulence.

	Viscosity	Density
Oxygen	1.11	1.11
70% N ₂ O / 30% O ₂	0.89	1.41
80% He / 20% O ₂	1.08	0.33

Viscosity and density relative to air

Could helium flow rate be accurately measured in an oxygen flowmeter?

Low flow - Yes, at low flow, flow is laminar and, as O₂ and He have similar viscosities, calibration accurate.

High flow - No, flow is turbulent, and as helium density lower, helium readings would be falsely low.

2) Temperature

Warming inspired gases increases critical flow (presumably by increasing viscosity and reducing density)
Cold patient → ↑ viscosity blood → ↓ flow

3) Variation in <i>critical flow</i> with tube diameter (anaesthetic gases)	9 mm	~ 9 l. min ⁻¹
	15 mm	~ 15 l. min ⁻¹
	22 mm	~ 22 l. min ⁻¹
4) Variation with breathing	Peak flow during	~ 50 l. min ⁻¹
	Thus, at peak flow	-turbulent; Quiet tidal breathing - laminar
5) Variation within respiratory tract	Flow slow in lower respiratory tract	- laminar

Bernoulli principle

What is a Venturi?

A tube with a constriction. The diameter decreases then increases

Bernoulli principle

If pressures are measured along the tube the lowest pressure will be found at the narrowest point.

Why?

Theory of conservation of energy: Energy of flowing fluid is conserved if frictional losses are minimal. Thus, when *kinetic* energy increases at constriction, *potential* energy must fall → pressure falls at constriction.

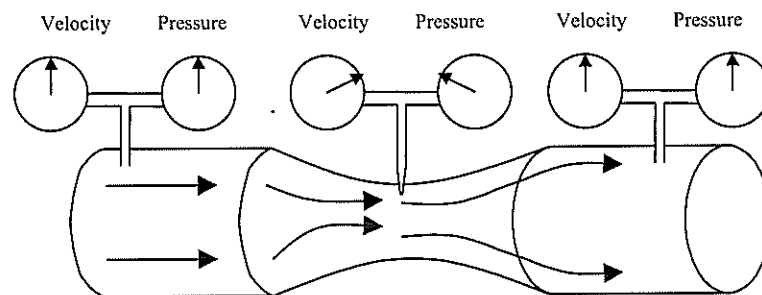

Bernoulli's principle demonstrated with fluid flow through a venturi.

Practical examples

Injectors
Suction devices
Nebulizers
Oxygen masks

Entrainment ratio

Entrained flow / Driving flow

Coanda effect

What is it?

The phenomenon of wall attachment. Liquid or gas flows through a constriction and enters a wide bore tube. There is no hole for air to be entrained so the stream *clings* to the wall of the tube. If the stream is entering a Y junction it will cling to one limb or the other, rather than dividing evenly.

Possible importance

Maldistribution of gas flow to alveoli after constriction
MI occurring in patent artery branch, distal to narrowing.
Switching valve in fluid-logic ventilators.

Stream clings to wall at area of low pressure and is deflected down one or other symmetrical channels

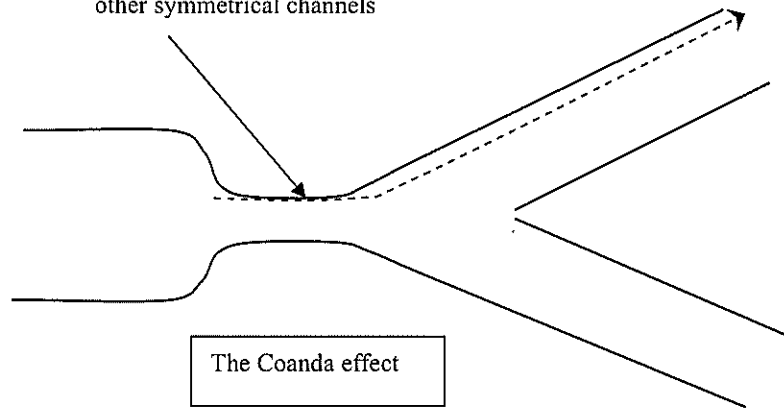

1

BIBLIOGRAPHY:

- 1) Parbrook, Davis, Parbrook. Basic physics and measurement in anaesthesia.
- 2) Scurr and Feldman. Scientific foundations of anaesthesia
- 3) Hull. Physics and anaesthesia in Nimmo, Smith, Rowbothom. Anaesthesia
- 4) Sykes, Vickers and Hull.. Principles of measurement and monitoring in anaesthesia and intensive care.
- 5) Ward. Anaesthetic equipment.
- 6) Nunn. Applied respiratory physiology.
- 7) Smith and Aitkenhead. Textbook of anaesthesia

GAS LAWS

Atomic structure

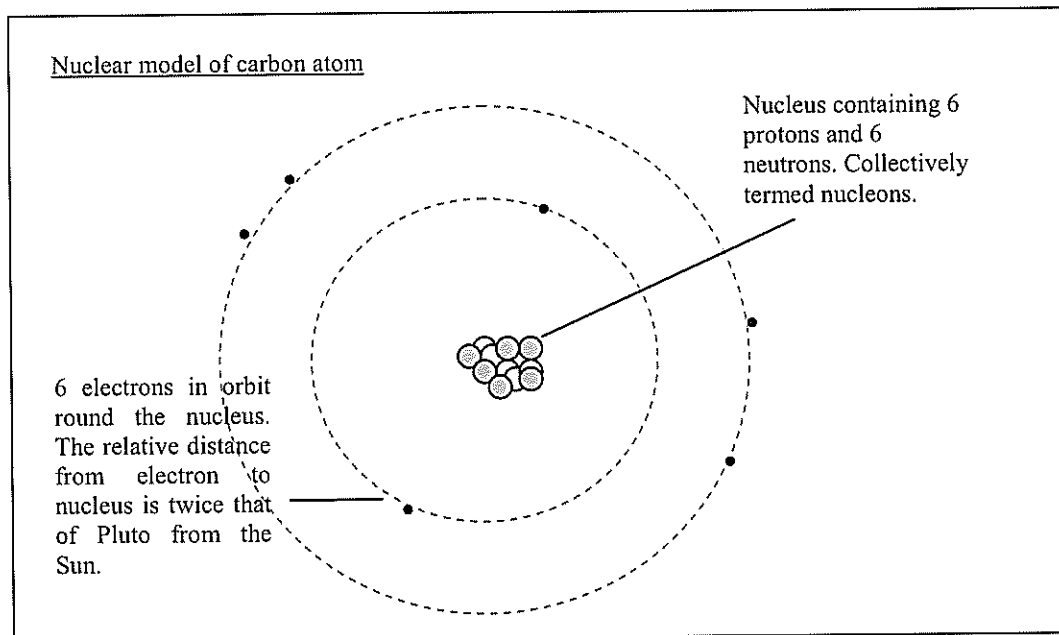

<i>Particle</i>	<i>Charge</i>	<i>Relative mass</i>
Proton	Positive +1	1
Neutron	Neutral, 0	1
Electron	Negative, -1	0.0005

Atomic number (or <i>Proton number</i>)	Number of protons in the nucleus Defines the element. No two elements have the same number of protons
Charge	In the usual neutral atom, the number of electrons equals the number of protons. Ions have different numbers of protons and electrons.
Relevance of number of electrons	Determines the reactions and chemical behaviour. Thus the proton number reveals a lot about an atom's chemical properties
Isotope	Atoms with the same number of protons but different numbers of neutrons. They all have the same number of electrons, so their <i>chemical</i> properties are the same. Hydrogen has 1 proton and 0 neutrons Deuterium has 1 proton and 1 neutron Tritium has 1 proton and 2 neutrons
Importance of neutron number	Doesn't affect chemical properties but the greater the number of neutrons, the more unstable the nucleus and the more likely to radioactive decay

Nuclear symbols

Mass number (nucleon number): Number of protons + neutrons in nucleus



Atomic number: Number protons in nucleus

Notation in the periodic table

Relative atomic mass: Average mass of all the isotopes. (Not usually a whole number) eg

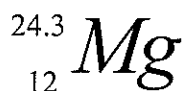

Atomic number: Number protons in nucleus

Atomic mass	Mass of protons, nucleons and electrons in the nucleus of a specific isotope (ie not the average of a number of isotopes) As the mass of electrons are ~ 1/2000 that of a proton, practically nothing, the atomic mass ≈ mass number.
Units of atomic mass	Atomic mass is too small to weigh! Therefore given in units of 1/12 atom of ${}^{12}\text{C}$. As ${}^{12}\text{C}$ has 6 protons and 6 neutrons in the nucleus, 1/12 mass of ${}^{12}\text{C}$ is one nucleon (ie a proton or a neutron). As the mass of elements is determined by the number of nucleons, the Atomic mass is the same as the Mass number.
Relative atomic mass	The average atomic mass of all the isotopes – not usually a whole number
Relative molecular mass	Sum of all the relative atomic masses in a <i>molecule</i>
What is a Mole (mol, n)	A dimensionless number analogous, perhaps, to a dozen.
How was it decided?	It is the number of atoms in 12g ${}^{12}\text{C}$. One mole turns out to be 6×10^{23} particles. By choosing 12 grams we enable this simple relationship: Mass one mole of atoms with 12 nucleons (carbon) = 12g Mass one mole of atoms with 1 nucleon = 1g Mass one mole of atoms with 4 nucleons = 4 g etc Thus the mass of one mole (<i>molar mass</i>) of a substance (ie the mass of 6×10^{23} molecules of the substance) is simply the Mass number or relative molecular mass expressed in grams
Avogadro's constant N_A	One mole of any gas contains the same number of particles: 6.02×10^{23} . (Remember from above that the number of particles did not define the mole, rather the mole was defined and the number of particles determined).

The gas laws

Background

There are actually 23 gas laws, most of which are *equations of state* in that they describe the state of matter under a given set of physical conditions.

Ideal gas

The gas laws are concerned with *ideal gas*. This is a hypothetical situation in which the gas has particles of zero volume and no intermolecular force. Also collisions between molecules and the walls of the container do not change the total energy of the molecules involved. This is termed elastic collision. See Raman scattering.

Perfect gas?

Some texts say that a perfect gas is synonymous with an ideal gas. Others say that a perfect gas is one in which the specific heats are not dependent on temperature

Real gas

Probably safe to regard this as synonymous with *gas* although there is dispute about this too!

What are Van der Waal forces?

Attractive or repulsive forces between molecules other than those due to covalent bonds or electrostatic interactions of ions. VdW forces differ from the above in that they are unstable and are caused by momentary polarization of particles.

Boyles's law

At a constant temperature the volume of a given mass of gas varies inversely with the absolute pressure.

$$V \propto 1/P \quad PV = \text{const} \quad (k1)$$

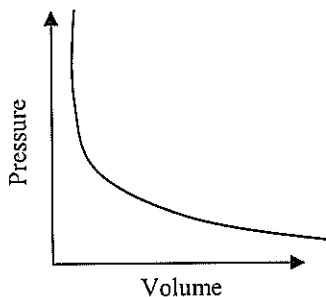

Practical examples :

i) Volume of O₂ available from cylinder can be calculated from cylinder (absolute) pressure.

ii) Body plethysmography

Charles's law

At constant pressure the volume of a given gas varies directly with the absolute temperature.

$$V \propto T$$

$$V/T = \text{const} \quad (k2)$$

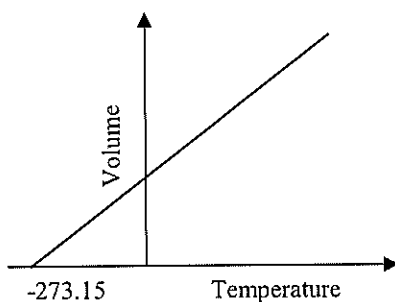

Practical examples:

i) Gases expand when heated

Third perfect gas law (Gay-Lussac's Law)

At constant volume the absolute pressure of a given mass of gas varies directly with the absolute temperature

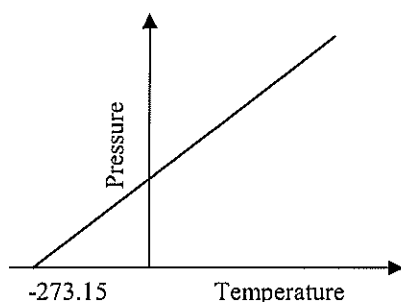

$$P \propto T$$

$$\frac{P}{T} = \text{constant } (k_3)$$

Practical examples:

- i) Explosion of heated cylinder
- ii) Hydrogen thermometer

Dalton's law of partial pressures

In a mixture of gases the pressure exerted by each gas is the same as that which it would exert if it alone occupied the container.

(Each molecule behaves almost independently of its neighbours and the pressure it generates is the same as if it were alone.)

Practical examples

- i) To create a cylinder of air at 100 kPa

Add a cylinder of O_2 at 21 kPa to a cylinder of N_2 at 79 kPa. Final cylinder pressure will be 100 kPa and will contain 21% O_2 and 79% N_2 .

Avogadro's hypothesis

Equal volumes of gases at the same temperature and pressure contain equal numbers of molecules.

How can this be true ?

It is true because the force exerted by an individual molecule of any ideal gas at a given temperature is the same despite differences in molecular mass. Hence, for gases at a given unit volume and at a given temperature, if the pressure of gases are the same they must contain the same number of molecules.

You can't determine the identity of a gas in a container through temperature; volume and pressure measurements alone

How is it that gas molecules of different mass all exert the same force?

The force exerted by a molecule on a 'wall' is equal to the rate of change of momentum. Thus, although a large molecule has greater momentum, it moves more slowly and the time lapse between impacts is proportionately longer. The force and pressure exerted by large, slow molecules is thus the same as that exerted by small, fast molecules.

Simplified proof (for your interest):

There will be an average kinetic energy per molecule of gas at a given temperature

$$\text{Kinetic energy of a molecule} = \frac{1}{2}mv^2$$

For this to hold true, if the mass increases the velocity must decrease.

eg What is the velocity of large molecule with mass $4m$ and same kinetic energy?

$$\text{K.E} = \frac{1}{2}(4m)\left(\frac{1}{2}v\right)^2 = \frac{1}{2}mv^2 \text{ Thus velocity must be } \left(\frac{1}{2}v\right) \text{ if kinetic energy is to be the same}$$

Thus, large molecule travels half as fast and will take twice as long between impacts. What will its momentum be?

$$\text{Momentum} = \text{mass} \cdot \text{velocity}$$

$$\text{Momentum large molecule} = (4m)\left(\frac{1}{2}v\right) = 2mv$$

But force on wall is the rate of change of momentum so although momentum doubled, the time between impacts has also doubled and force exerted stays the same

Volume of one mole of gas (STP)

22.4litre

Volume one mole of gas (SLC)

24.45 litre (Standard lab conditions 25°C , 1 atmosphere)

Practical examples

i) Calculation of volume remaining in N_2O cylinder.

$$\text{Volume} = 22.4 \text{ L} \times \text{N}_2\text{O mass} / 44\text{g}$$

Why is your calculation likely to underestimate the actual volume?

22.4 l is the volume of a mole at STP. It will be greater at room temperature.

Ideal gas law

The three gas laws above can be combined such that, for 1 mole of any gas $PV / T = R$ (the universal gas constant)

More commonly written version

$$P.V = n.R.T \text{ (where } n = \text{ number of moles)}$$

What does R represent?

The kinetic energy change per mole per unit absolute temperature. The value is approximately the same for one mole of any gas.

Value and units

$$8.314 \quad \text{J} / \text{mol.K}$$

What is Boltzmann's constant? (k)

The equivalent of R for one particle of a gas ie $R / \text{number of particles in the gas}$

Practical importance

i) Individual gas laws

ii) Regnaults hygrometer

iii) Explanation that cylinder pressure proportional to number of moles of gas

Note: The above applies to ideal gases only. For 'real' gases there are correction factors which allow for attraction between molecules and the volume occupied by the molecules.

$$RT = (P + a/V^2)(V - b)$$

a - corrects for attraction between molecules

b - corrects for volume of molecules

See 'Scientific Foundations' for fuller explanation.

Critical temperature

The temperature above which a substance cannot be liquified by pressure alone.

Critical pressure

Pressure required to liquify a substance at its critical temperature

Definition of a vapour

A substance in a gaseous-type state at or below it's critical temperature.

Practical examples

O₂ is a gas at room temperature. N₂O cylinder contains liquid unless it is heated above 36.5 °C when it can only exist as a gas.

Henry's Law

At a constant temperature the volume of gas going into solution is proportional to the partial pressure of the gas in equilibrium with the liquid.

Isotherms:

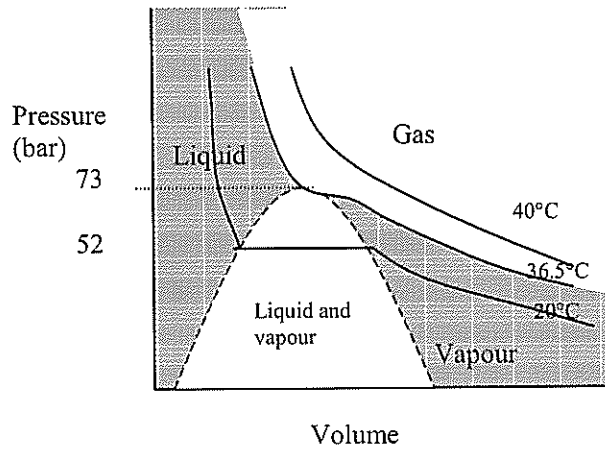

Three isotherms for N₂O showing change in pressure and state as a volume of N₂O is gradually compressed. Three different temperatures are shown:

Explanation:

40 °C

Above the critical temperature there is a smooth increase in pressure as the gas is compressed. Thus Boyle's law is obeyed.

20 °C

Below the critical temperature, as the vapour is compressed the pressure rises and, when the saturated vapour pressure, 52 bar, is reached, the N₂O starts to liquify. Further compression simply causes more liquifaction and the pressure remains the same. Once all the vapour has condensed into liquid, further compression results in a sharp rise in pressure as liquids are less compressible.

36.5 °C

Compression at the critical temperature will produce liquifaction only once the critical pressure of 73 bar is reached.

Practical examples

Filling ratio

If there was only liquid in a full N₂O cylinder, heating would cause the liquid to expand and, because liquids are relatively incompressible, there would be a sharp increase in pressure and a risk of explosion.

Thus, cylinders only partially filled so that heating → liquid expansion → compression of N₂O vapour → condensation of vapour and limitation of pressure rise.

Definition filling ratio

Mass of "gas" in a cylinder divided by mass of water which would fill cylinder. Remember that as the mass of 1 kg water equals 1 litre, the denominator can also be the volume of the cylinder in litres.

Filling ratio for N₂O

0.65 (Parbrooke); 0.67 (Russell; Smith and Aitkenhead)

Pseudocritical temperature

When there is a mixture of gases there is a specific critical temperature at which the gas mixture separates out into its constituents.

Practical example

i) Pseudocritical temperature Entenox

- 5.5 °C, although in a *full* cylinder, separation may not start to occur until a temperature of - 7 °C is reached.

Importance of pressure to pseudocritical temperature

Separation most likely at 117 bar. Above and below this, separation is less likely. eg Pseudocritical temperature of pipeline Entenox at 4.1 bar is much lower at about - 30 °C

SOLUBILITY

Henry's Law

At a given temperature the amount of a given gas dissolved in a given liquid is directly proportional to the partial pressure of the gas in equilibrium with the liquid.

What does the amount of gas dissolved in a liquid depend on?

Partial pressure of gas
Temperature - \uparrow temperature \rightarrow \downarrow amount gas in solution
Chemical reactions
Gas - eg N_2O more soluble than N_2
Liquid - eg N_2O more soluble in blood than water

Bunsen solubility coefficient

Volume of gas which dissolves in one unit volume of the liquid at the temperature concerned where the partial pressure of the gas above the liquid is *one standard atmospheric pressure*. The amount is expressed as the volume the gas would occupy when brought to STP

What is s.t.p?

273.15 K (0 ° C) and 101.325 kPa

Ostwald solubility coefficient

Volume of gas which dissolves in one unit volume of the liquid at the *ambient pressure pertaining*. temperature concerned. Amount expressed as the volume the gas would occupy at the ambient pressure and temperature pertaining.

Practical difference

If the coefficients were calculated at the same temperature (ie 0°C) the coefficients will be the same no matter what partial pressure is. This is because while a higher partial pressure forces more molecules into solution, by Boyles law, that higher pressure will also compress down the gas volume. Thus the Bunsen solubility coefficient will be the same as the Ostwald coefficient no matter what the partial pressure is (if the temperatures are the same)

Partition coefficient

The ratio of the amount of substance present in one phase compared with another, the two phases being of equal volume and being in equilibrium. (Thus the gas tension will be the same in both phases).





What is meant by the tension of gas in solution? The partial pressure of the gas which would be in equilibrium with it.

CEREBRAL MONITORING

Electroencephalograph

What does it do?	Measures the voltages (in μV) of post-synaptic potentials of cortical dendrites.
Standard system	'10 - 20' system. (Electrodes placed 10 % of circumferential distance above the inion and EAM and 20 % of circumferential distance apart)
Number of electrodes	20 + reference electrodes
Number channels recorded	16
Problems	Equipment cumbersome Massive paper production Interference from movement, noise, power lines, other equipment (ECG, diathermy). Interpretation requires considerable expertise

Rhythm Frequency (Hz) Amplitude (μV)

Beta	> 12 Hz	< 20		Awake, alert, mental activity
Alpha	8 - 12 Hz	20 - 50		Awake, relaxed, eyes closed
Theta	4 - 7 Hz	> 50		Sleep, anaesthesia
Delta	< 4 Hz	> 75		Deep sleep Deep anaesthesia Pathological states Hypoxia

↓ Slower, more synchronous

Basic EEG rhythms

Physiological variations on the EEG

1) Age	Infants - Fast beta + slow occipital activity Adults - More alpha Elderly - slower. Less stages sleep stages 3 and 4
2) Alpha block	Occurs when eyes open, mental activity, sensory stimulation. Fast, irregular, desynchronous, low voltage activity, <i>no dominant frequency</i> .

3) Sleep

Neurobiology of sleep
Actively generated in

Not merely a loss of wakefulness.

- i) the suprachiasmatic nuclei (SCN) of the hypothalamus where circadian rhythm is mediated
- ii) the brainstem pontine reticular activating system where the cyclical oscillation between REM and NREM (ultradian rhythm) is mediated.

What is the normal sleep cycle?

Approximately 90 minutes per cycle. More REM and less stages 3 and 4 as night goes on. Less stages 3 and 4 in elderly.
4 – 6 REM periods per night

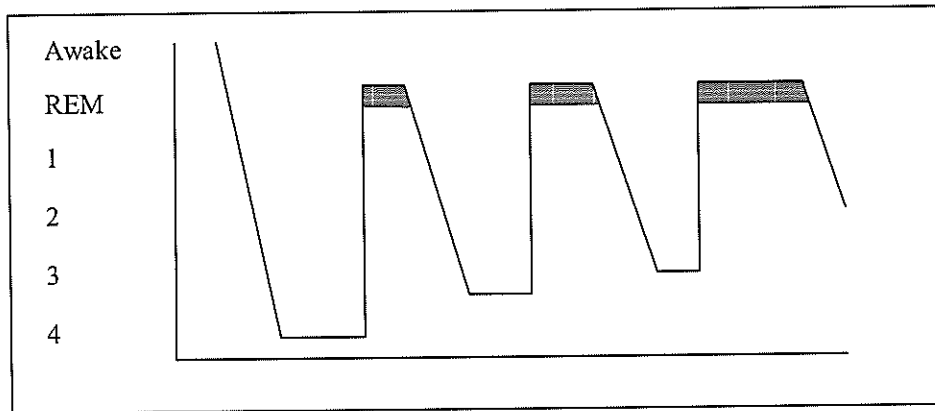

Non REM stages

As the patient falls asleep, their EEG activity changes from being rapid and desynchronous to slower and more synchronous. Once asleep they cycle through the four stages smoothly, the threshold for arousal being highest in stage 4. In deep slow wave sleep, muscles are relaxed and sympathetic activity, BP and HR are reduced.

Awake and alert – rapid, desynchronous, low voltage

↓

Awake relaxed eyes closed – slower more synchronous (alpha)

↓

Stage 1 – low amplitude theta

Stage 2 – theta plus sleep spindles and K complexes

Stage 3 (deep sleep) – delta

Sleep spindles: Probably generated in thalamus and are associated with ability to maintain sleep in presence of disruptive sounds

K complexes: The largest EEG event. Involved in suppressing cortical arousal in response to stimuli that the sleeping brain evaluates not to signal danger.

REM

Fast, desynchronous, low voltage EEG resembling alert state. Hence term *paradoxical sleep* as there is an increased threshold for arousal. Associated with - muscle relaxation (↑ activity in reticular inhibiting area of medulla), dreaming, teeth grinding, airway obstruction, rapid eye movement, autonomic dysregulation including sympathetic activation.

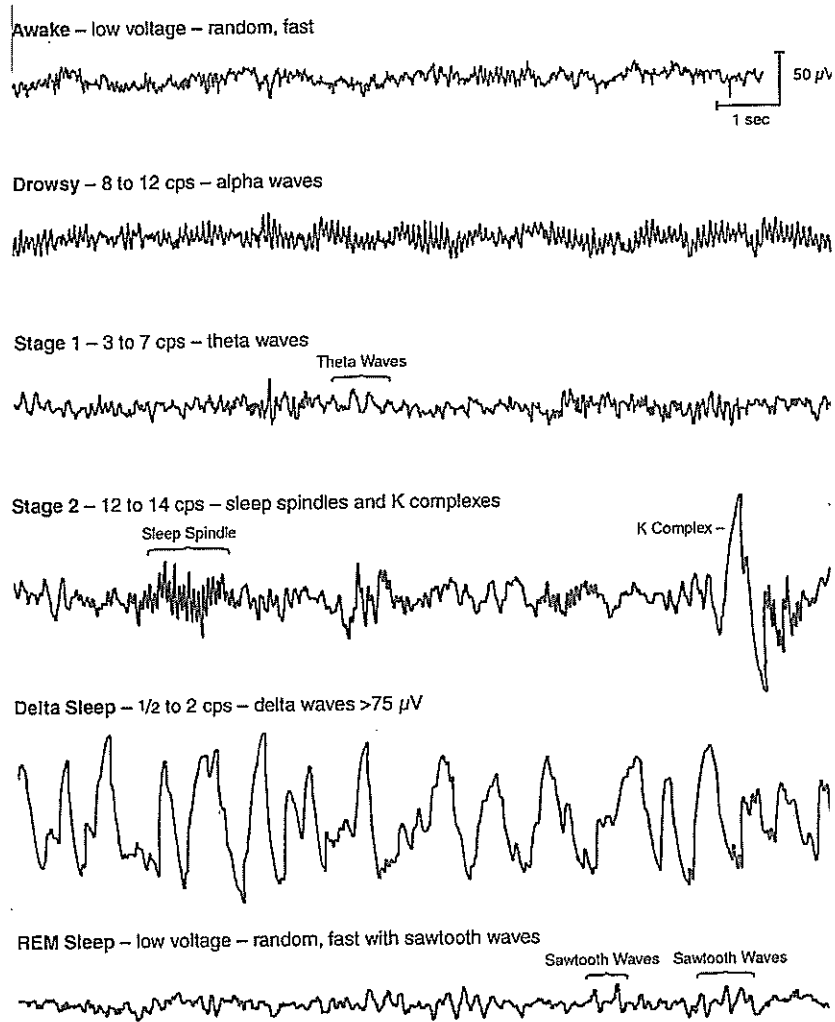

EEG patterns awake and asleep. Note: Deep sleep often referred to as Stage 3.

EEG in pathological states

Pathology	EEG response
Cerebral ischaemia	Faster onset of changes (10 secs) compared with drugs and hypothermia ± Fie pattern – fast, low amplitude (chemoreceptor stimulation of RAS) → slowing + ↑ amplitude → ↓ amplitude → isoelectric after 20 to 40 sec
Hypercapnia	Initially fast → slowing with decreased amplitude
Hypothermia	Progressive slowing and decreasing amplitude At 20° C – frontal waves only
Hypo- and hyperglycaemia	Slowing
Hypo- and hypernatraemia	Slowing
Sensory stimulation	Fast, low amplitude
Grand mal seizure	Aura - ↑ amplitude in pre-motor region

Petit mal
Encephalopathy
CPB

Tonic – Spikes
Clonic – Spikes and slow waves
Post ictal – Random slow waves
3/s spike and slow waves
Delta waves
Abnormalities for 2 days to 2 weeks
During perfusion - slowing of EEG

NB - The overlap between the EEG effects of ischaemia and anaesthesia (as well as many of the above factors) means that there is much ambiguity in intraoperative EEG and QEEG interpretation.

- While ischaemia may be sufficient to abolish EEG activity there may be enough flow to maintain cellular integrity. Hence the discrepancy between EEG changes and outcome.

The EEG in anaesthesia

Basic pattern

Induction of anaesthesia initially produces a decrease in alpha activity and an increase in beta activity. With increasing depth of anaesthesia, theta and delta rhythms predominate with progression to burst suppression and finally, particularly with thiopentone and isoflurane, isoelectricity.

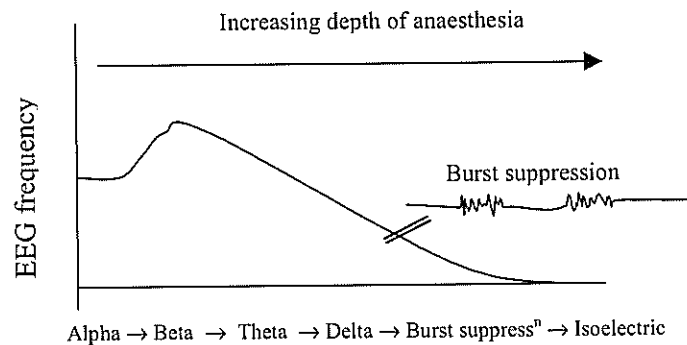

Drug	EEG effect
Thiopentone, propofol, etomidate	As for basic pattern including suppression of EEG
Ketamine	Disorganised frontal activity. Paradoxical effects on BIS. Electrical silence does not occur.
Diazepam	Similar to basic pattern
Isoflurane	Basic pattern. Potent depression of the EEG with isoelectricity at 2.0 to 2.5 MAC
Desflurane Sevoflurane	Similar to isoflurane Similar to isoflurane although epileptiform type activity is sometimes seen. This has not been associated with clinical seizure activity
Halothane	Basic pattern but not isoelectric at normal doses
Enflurane	Basic pattern but not isoelectric at normal doses Seizure activity, particularly in association with

N₂O hypocapnia and concentrations > 2.5%
Fast frontal activity with disorganisation . No independent effect on BIS.

Opioids Dose related slowing and increase in amplitude.
Complete suppression not possible.
Epileptiform activity at high doses.

Bispectral index

Summary An index of the hypnotic state of the brain which is scored using complex EEG processing and then comparison of the result with an in-built algorithm.

Principle EEG was obtained from over 2000 patients receiving commonly used anaesthetic agents.
EEG was then analysed by several signal processing techniques including:

- *Burst suppression*
- *Beta activity*
- *Power spectrum analysis*
- *Bi-spectral contribution: This is a 'third-order' statistical technique which examines 'coupling' or phase relationships between the sine waves.*

NB: Descriptions of the above analysis often use the following broad terms:
Time domain analysis: How a signal changes over time
Frequency domain analysis: Analysis of the frequencies found in the signal

Each set of variables was then ranked in their ability to predict a level of hypnosis. The weighted sum of the variables is the BIS number.
When the monitor is in operation, it records and processes the signal and assigns a score according to the BIS algorithm from 100 (awake) to 0 (no brain activity).

<i>Level of hypnosis</i>	
100-85	Awake
85-60	Sedation General anaesthesia suitable for surgery
40-30	Deep anaesthesia
30-0	Burst suppression
< 70	Low risk of explicit recall
< 60	Low probability of consciousness

Commercially available devices Manufactured by *Aspect Medical Systems Inc. and SpaceLabs Medical Inc. USA.* Incorporated into *Datex Ohmeda* monitor as the EEG Module-M

Cautions with BIS monitoring

1. Agent dependency Degree of depression of BIS is dependent on agent used:
Propofol, STP, Midazolam > Isoflurane > Halothane
Opioids, N₂O negligible effect
Ketamine has paradoxical effects
BIS 'blind' to N₂O therefore anaesthesia may be deepened unnecessarily (*Sleigh, Anderson*)

2. Titration of anaesthetic concentration: BIS correlates poorly with End-tidal anaesthetic concentration. BIS is therefore incapable of finely guiding volatile anaesthetic titration during anaesthetic maintenance. (Anesthesiology 115(6): 1209-1218+ Sleigh editorial.)
3. PPV and NPV for awareness Not 100% - nor do we expect any monitor or test to be!
4. Inter-individual variation (*Anderson Feb 2004*)
5. Artefact (EMG, ECG, eye blink, diathermy) Newer technology has ↓ artefact problems
6. Not fully validated in paediatric patients but much research underway

Ability of BIS to reduce awareness – summary of research to date

Safe-1 Trial (2000-2) Prospective observational study. 11,785 patients. Incidence of awareness was 0.18% in those given neuromuscular blocking drugs (NMBs) and 0.10% in the absence of NMBs. 18 cases of awareness with explicit recall identified among the 11,785 patients. (*Lancet. 355(9205):707-11, 2000*)

SAFE-2 study (2004): Prospective observational trial with historical control. 7826 patients receiving standard GA compared with 4945 patients who received BIS-guided anaesthesia. Two patients in the BIS-monitored group (0.04%) had ER as compared with 0.18% in the control group (P < 0.038). Routine use of BIS reduced incidence of awareness in the general patient population by 77% compared with historical control. (*Acta Anaesthesiologica Scandinavica. 48(1):20-6, 2004*)

AIM Trial (2004) Prospective USA observational trial. 19,575 patients. Awareness with recall occurs in the USA at a rate of 1-2 cases per 1000 patients receiving general anaesthesia. Use of BIS not associated with lower awareness rate (*Anesth Analg 2004; 99: 833-9.*)

B-aware study (2004) RCT. High risk patients. 2 reports of awareness out of 1225 BIS guided anaesthetics; 11 reports out of 1238 with routine care group. Reduction in incidence of awareness by 82%. NNT- 138 (*Lancet 2004; 363: 1757-63.*)

“B-Unaware” study (2008).. RCT. High risk patients. 967 in BIS group and 974 in control (MAC kept between 0.7 and 1.3). Two cases of definite awareness in each group. Overall incidence of awareness 0.21%. Findings do not support routine use of BIS as standard practice. (*NEJM. 2008. 358(11):1097-108,*)

“B-unaware” study (2011). RCT. High risk. Multicentre. Definite awareness: BIS 7/2861 (0.24%) vs ETAC 2/2852 (0.07%). Possible awareness: BIS 19/2861 (0.66%) vs ETAC 8/2852 (0.28%). Thus, superiority of BIS not established. (*NEJM. 2011. 365(7):591-600,*)

Entropy

Summary

A new non-linear statistical parameter describing the order of chaotic data. Implication is that the EEG is not a summation of sine waves but a chaotic, non-linear system. Spectral entropy of the awake state (chaotic, many different microstates) is 100 whereas spectral entropy of one single perfect sine wave is zero. As anaesthesia deepens the EEG activity across the cortex becomes synchronised with delta wave activity predominating. Thus, there is a tendency for entropy scores to fall.

Monitor

Datex-Ohmeda (M-Entropy plug in Module S/5™ 3-electrode system.

State entropy

EEG dominated frequency range 0.08 – 32 Hz Range 0 - 91

Response entropy What is purpose of RE?	EMG included as well as EEG 0.08 – 47 Hz Range 0 – 100 The EMG (frontalis 32 – 47Hz) response is faster and gives earlier indication of patient arousal.
Spectral entropy and anaesthesia level	Similar scale to BIS with a score < 60 implying surgical anaesthesia

Entropy validity notes
Good correlation between propofol sedation and entropy indices (<i>Bruhn</i>)
Entropy processing of commercially available monitor shows good correlation with propofol sedation (<i>Anderson</i>)
Entropy processing more sensitive in assessing recovery than other techniques (<i>Muncaster</i>)
EEG entropy does not change with N ₂ O sedation. If entropy (or BIS) used to monitor conscious level when N ₂ O used, anaesthesia may be deepened unnecessarily. (<i>Anderson</i>)

Narcotrend index

Method	Similar principle to above two. Depth of anaesthesia graded A – F (based on 1939 Loomis classification) Signal digitised and analysed by complex methods including spectral and entropy analysis. Statistical analysis determined the best EEG features that characterise each level of anaesthesia. Scoring to produce numerical scale between 0 and 100.
--------	--

Auditory evoked potentials (AEP's)

Summary	Response of the brainstem, mid brain and, to a lesser degree, the cortex to acoustic stimulus of the auditory nerve.
Stimulus	Loud click, 60 - 70 dB greater than click-hearing threshold. 1000 - 2000 10 Hz repetitions averaged. The more averaged, the better the reduction in back ground noise but the longer the measurement and the delay. Mono-aural, white noise to contralateral ear.
Electrode placement (Danmeter AEP/2)	<i>Active electrode-</i> Vertex or high forehead <i>Ground electrode-</i> Low forehead <i>Reference electrode –</i> Inion or Mastoid. Mastoid not recommended because posterior auricular muscle activity, which is stimulated by loud sounds, can cause interference. (<i>Tooley</i>)
Which potentials ?	<u>Brainstem AEP (BAEP)</u> Latencies shorter than 10 ms. BAEP waves I-V represent cochlea, acoustic nv. and brainstem. Used to monitor collateral damage in acoustic neuroma and other post fossa surgery. <u>Mid latency AEP (MLAEP)</u> ~ 1 µV amplitude. Latencies of 10-50 ms. Medial geniculate and auditory cortex of temporal lobe. Most commonly studied waveforms are Pa and Nb. The MLAEP's show high intra and inter-individual stability and the most commonly studied in depth of anaesthesia monitors.

Late latency AEP (LLAEP) Latency of >100ms. Frontal cortex and other fields. Very variable in awake state. Not used in depth of anaesthesia monitors.

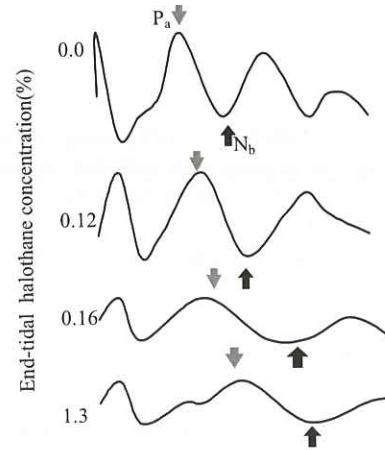
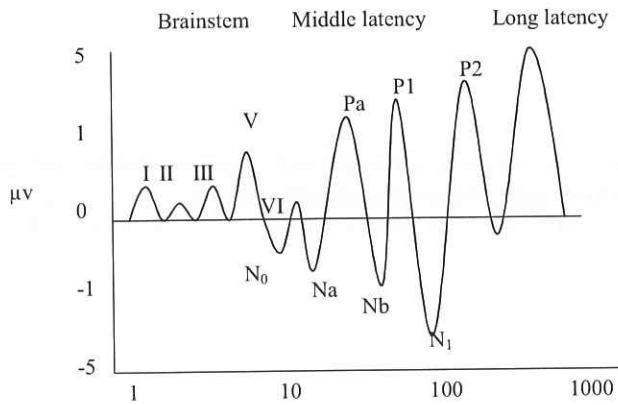

Effect of increasing concentrations of halothane on amplitude and latency of MLAEP.s

- Why MLAEP's in depth of anaesthesia? MLAEP show graded changes over clinical concentrations of anaesthetics. BAEP sensitive to inhalational agents but not to intravenous agents, therefore not used in this context. LLAEP's disappear at sedative concentrations.
- Which MLAEP's are used? Most commonly, the amplitude and latency of Pa and Nb. Amplitude decreases and latency increases with increasing concentration of anaesthetic
- Surgical stimulation? ↑ amplitude but latency of Pa and Nb unaffected
- Is there an equivalent index to the BIS? Yes, the AAI (A-line ARX index) is calculated from MLAEP's. It is used in monitors such as the AEP/2 monitor of *Danmeter AAI™*.
- AAI™ index The AAI™ index now is a combination of AEP response *and* processed EEG analysis with the former dominating the index. Idea is that during deep anaesthesia AEP is suppressed more than EEG so changes in DOA will be mainly reflected by the changes in the latter.
- Still a long delay? Not so much because of a special technique (ARX modelling) to extract the AEP signal from the raw EEG. Only 15-25 sweeps required with average delay approximately 2-6 seconds.

AAI	Hypnosis level
100-60	Awake
60-40	Sedation
40-30	Light anaesthesia
30-20	General anaesthesia. AAI index of 30 ≈ BIS 50
20-0	Deep hypnosis
< 10	Burst suppression or flat EEG

AAI validity notes
Good indicator of level of hypnosis in anaesthetised patients
Inter-patient variability may limit its' usefulness in identifying awareness thresholds.
Large variation in predictive arousal threshold values for different drug combinations or different anaesthetic agents. For example, introduction of ketamine, opioid or N ₂ O has no effect on MLAEP but does decrease the value at which arousal occurs
Not useful in hearing problems and loud background noise
The post-auricular response (PAR) in tense patients may contaminate AEP. Less of a problem if NM blockers used or if inion electrode used.

Notes:

1. Wrong to assume that anaesthesia is a single state reflected by electrical behaviour of the cortex. MAC is our most commonly used end-point and our most classical index of anaesthetic potency yet it is largely dependent on the agent's action on the spinal cord, not on the cerebral cortex.
2. N₂O, Xenon, Ketamine cause a loss of consciousness but cortical activity is maintained – even when the patient is anaesthetised. How? Possibly by disorganising cortical activity. Thus, N₂O state may be analogous to REM sleep. Therefore, does a change in the state of consciousness reliably cause a detectable change in measured electrical activity in the frontal cortex? Not necessarily. When agents cause a loss of consciousness in association with depression of cortical activity, BIS and Entropy monitors are indirect indicators of conscious levels. When LOC occurs without cerebral depression the monitors are not (Ref: Various)
3. General anaesthetics have effects on multiple systems, and titrating doses to a single parameter such as BIS value is dubious, particularly when we don't fully understand the underlying mechanisms of the drugs, the EEG algorithm or the validity of the monitor

Compressed spectral array

Principle-

- i) Signal is digitised in time intervals (epochs)
- ii) The signal is divided into its separate frequencies by fast Fourier analysis.
- iii) Each waveform is represented by a bar whose height is the square of the amplitude.
- iv) The bars are plotted according to the waveform frequency.
- v) Then compressed and smoothed

The spectral edge frequency

The frequency which lies at the right hand edge of 95% of an epoch's total frequencies. It is marked on the screen by a box and the movement of the box to the left or the right, as successive epochs are shown, gives a quick indication as to which frequencies are most predominant \therefore with increasing depth of anaesthesia or ischaemia the SEF moves to the left.

Middle frequency

Frequency which lies at the right hand edge of 50% of an epoch's total frequencies.

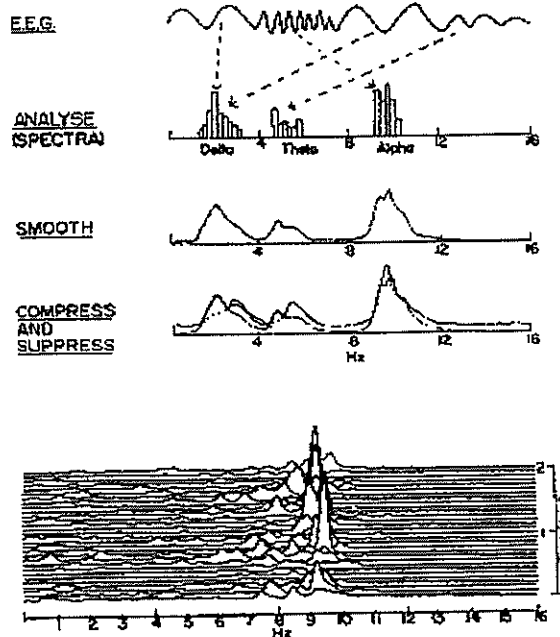

Applications

Brain perfusion

Depth of anaesthesia

carotid artery surgery

hypotensive anaesthesia

Not usually in this form (SEF and MF both increase in light)

Summary of depth of anaesthesia monitors

<i>Summary of depth of anaesthesia monitors</i>		
Method	Comment	
Clinical	Clinical acumen in theatre	HR, BP, sweating, lacrimation, papillary dilatation.
	PRST score	Pressure, heart rate, sweating, tears incorporated into a score. Poor correlation with isolated arm responses
	Isolated arm technique.	Impractical. A research tool only
EEG	Bi-spectral index	Burst suppression, power and bi-spectral analysis of EEG and comparison with hypnosis scoring algorithm. Stand-alone monitor or incorporated into multi functional monitors.
	Entropy	A very new non-linear statistical parameter describing the order of chaotic data. Implication is that the EEG is not a summation of sine waves but a chaotic, non-linear system. Commercially available instrument by <i>Datex-Ohmeda</i> .
	Narcotrend	Cerebrogram from 100 to 0. Depth of anaesthesia graded A – F (based on 1939 Loomis classification) Signal digitised and analysed by complex methods including spectral and entropy analysis. Narcotrend (<i>MT MonitorTechnik Inc., Germany</i>).
	Cerebral state index	Hand held monitor that analyses the frequency shift and BS in the EEG as depth of anaesthesia changes. Scale from 100 – 0 (<i>Cerebral State Monitor Danmeter A/S</i>)
	Power spectral array (SEF, MF, burst suppression)	Uses Fast Fourier Transformation to analyse raw EEG in epochs. Principle use is as monitor of brain perfusion. Not specific enough on it's own for depth of anaesthesia monitor. Used along with BIS and AEP in <i>Datex-Ohmeda</i> module (EEG Module-M)
	Patient state index (PSI)	PSI compiled from Quantitative EEG processing (mostly power analysis) in different hypnotic states. Recordings made using 19 channel EEG and compared with PSI algorithm. Available monitor is the Patient State Analyser (PSM4000) <i>Physiometrix, USA</i> .
Auditory Evoked Potentials	AEP index	Index based on amplitude and latency of MLAEP's. Examples of monitors are the AEP monitor of <i>Alaris Medical Systems</i> and the <i>Danmeter</i> the AAI TM monitor
Lower oesophageal contractility		Changes in contractility correlate well with MAC of inhalational agents but not intravenous. However much inter-patient variability
Heart rate variability	ECG analysis	ECG parameters such as loss of sinus arrhythmia and heart rate variability with increasing depth anaesthesia. Poor sensitivity and specificity. <i>Anemon-I, MCSA</i> . Advertised as a depth of analgesia monitor.

Other neuroanaesthesia monitors

Cerebral function monitor (CFM)

Electrodes-	2 x parietal
Principle -	Zero cross frequency x mean amplitude
Normal power	8 - 10 $\mu\text{V}/\text{sec}$

ZCF = number of times EEG crosses the line in one epoch

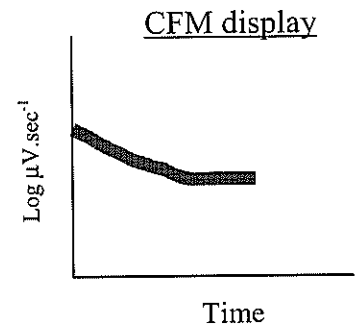
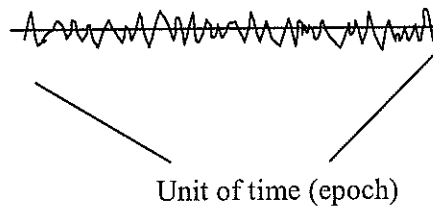

Advantage	Simplicity, ease of interpretation
Disadvantage	No information as to type (freq or amp) of waveform or focal/regional differences. Mostly has been superseded by more advanced monitors.
Possible uses	Detection of global or hemispheric dysfunction Prediction of outcome: > 10 μV - survival poss. < 3 μV - death
Variation	Cerebral function analyser monitor (CFAM) - gives amount of each frequency as well.

Somatosensory evoked potentials (SSEP's)

What are they?	Computed averages of the brain's response to repetitive peripheral nerve stimulation.
Peripheral nerve stimulated	eg median nerve, posterior tibial or common peroneal.
Stimulus	100 to 1000 small shocks; 1-2 Hz; 0.2 - 2 ms duration
Pathways	1st order: sensory nv.- DRG - dorsal columns - c/g nuclei. 2nd order: cun/grac nuc - med. lemniscus - contralateral thalamus 3rd order: thalamus - frontoparietal sensory cortex
Recording electrodes (several levels)	eg median nerve: Supraclavicular (brachial plexus) C2 posteriorly (gracile / cuneate nuclei)

	Contralateral scalp (parietal cortex)
1° evoked response -	Earliest activity. Only these are recorded intraoperatively. Less influenced by anaesthetic agents.
2° evoked response -	Longer latency. Too much variability.
Non-specific -	Diffuse across frontal and temporal cortex. May include cognitive and physiological responses to stimulus.
Near field potentials	Generated close to recording electrodes
Far field potentials	Generated distant from recording electrode and, therefore, of lower voltage. More stimuli required to be averaged. eg BAEP's recorded by vertex electrodes.

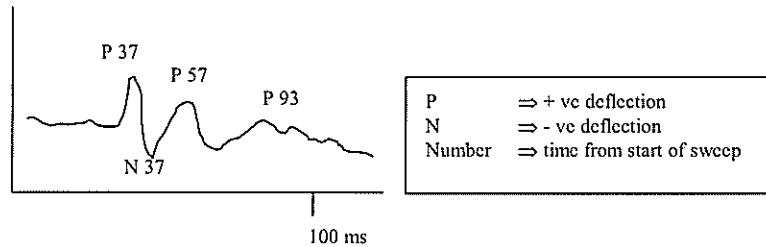

Measurements:	Amplitude of evoked responses
	Absolute latency Time to first cortical response. ↑ with lower limb stim.
	Interpeak latencies N9 to N14 (proximal brachial plexus to cv. nv roots.- dors. cols.)
	N14 to N19 (<i>central conduction time</i> ; dors.col. nucleus to cortex ~ 5.2 ms)
In general, signal varies with	Applied stimulus
	Body size
	Conduction velocity of axons
	No. of synapses
	Pathology
	Anaesthesia
Central conduction time depends on	Central axonal conduction
	Synaptic delay
	Pathology - SAH, surgical damage, head injury
CCT not affected by	Body size
	Peripheral nerve damage
Applications	Monitoring during and after surgery (carotid artery, intracranial aneurysm surgery, spinal cord surgery, aneurysm (false +ves), post fossa)
	Diagnostic Injury to spinal cord, brachial plexus
	MS or other demyelinating condition

Visual evoked responses

100 flashes of light →

parietal, occipital central scalp electrodes

Uses

Detection of MS

Surgery near optic nerves - meningioma
pituitary sx

Motor evoked potentials

Motor cortex stimulated electrically or magnetically. Response recorded from lateral column spinal cord or spinal epidural space. Most useful for operations that pose risk to the anterior segments with little effect on posterior cord.

INTRACRANIAL PRESSURE MONITORING

Applications/indications for intracranial pressure monitoring

Post operative monitoring
 Raised ICP for whatever reason eg brain tumour, encephalopathy, head injury
 Intracranial haemorrhage, aneurysm
 Coma
 To aid correct positioning of head in ICU or theatre
 To detect and manage increases in ICP in ventilated ICU patient after head injury or intracranial surgery
 Post operatively to detect raised ICP at closure of bone flap

Intracranial pressure monitors

<i>Intracranial pressure monitors</i>			
Site of placement	Ventricular	Gold standard; usually placed in lat ventricle during surgery although a version is available for tunnelling after a burr hole; usually saline filled catheter connected to external transducer; allows CSF drainage; monitors global pressure; compliance can be measured (1 ml → ↑ 2 mmHg);	Problems: risk of infection 3-11%, haemorrhage, damage to brain, accidental venting of CSF
	Parenchymal probe	Probe inserted into brain parenchyma; may be placed via burr hole; reasonable accuracy	Unable to drain CSF; unable to be re-zeroed *
	Subarachnoid bolt and catheter	Inserted via burr hole in fronto-parietal suture line through dura and into CSF; transducer remote or intracranial, easy to site; less invasive than ventricular; more accurate than extradural;	Usually unable to drain CSF; Transducer tip may rest on brain and obstruct; Tend to under-read at pressures > 20 mmHg
	Subdural probe	Probe inserted through burr hole then through dura but not through arachnoid;	Unable to be re-zeroed*; unable to drain CSF; limited accuracy
	Extradural probe	Probe inserted through burr hole into extradural space; dura not penetrated;	Unable to be re-zeroed*; fairly inaccurate; signal damping
Types of transducers	External fluid filled transducers		Essentially the same principals as A-line monitoring; used for ventricular and subarachnoid placement Solid state pressure sensor / strain gauge at tip. Zeroed prior to insertion but cannot be re-zeroed. Movement of diaphragm at tip is sensed by change in reflection of light
	Internal strain gauge	eg Gaeltec	
	Fibreoptic	eg Camino	
	Air pouch	eg Siepelberg *this can re-zero itself	

Notes on practical issues

Where do you zero transducer ? External auditory meatus. Correct for differences between heart and head when calculating CPP.

General points: They don't give an indication of infratentorial pressure.
 Most useful if catheter placed in CSF, allowing aspiration of CSF.

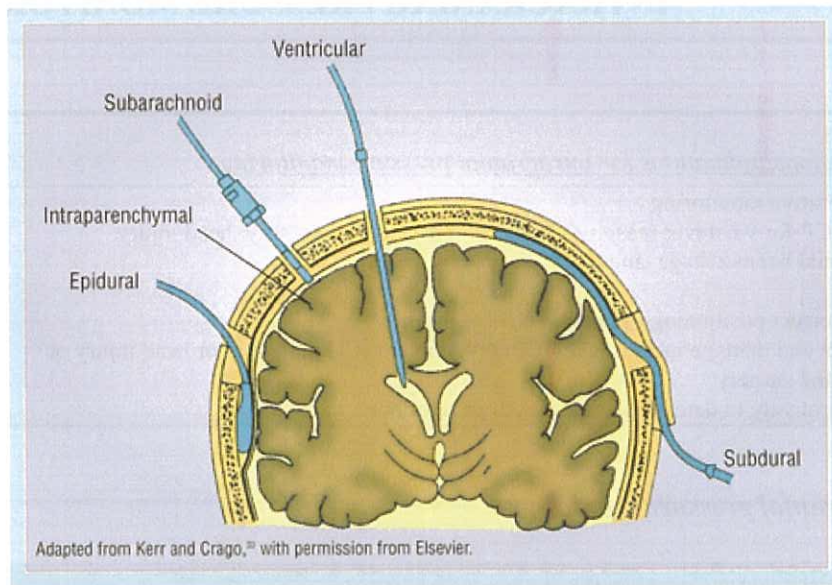

ICP waveforms during raised intracranial pressure

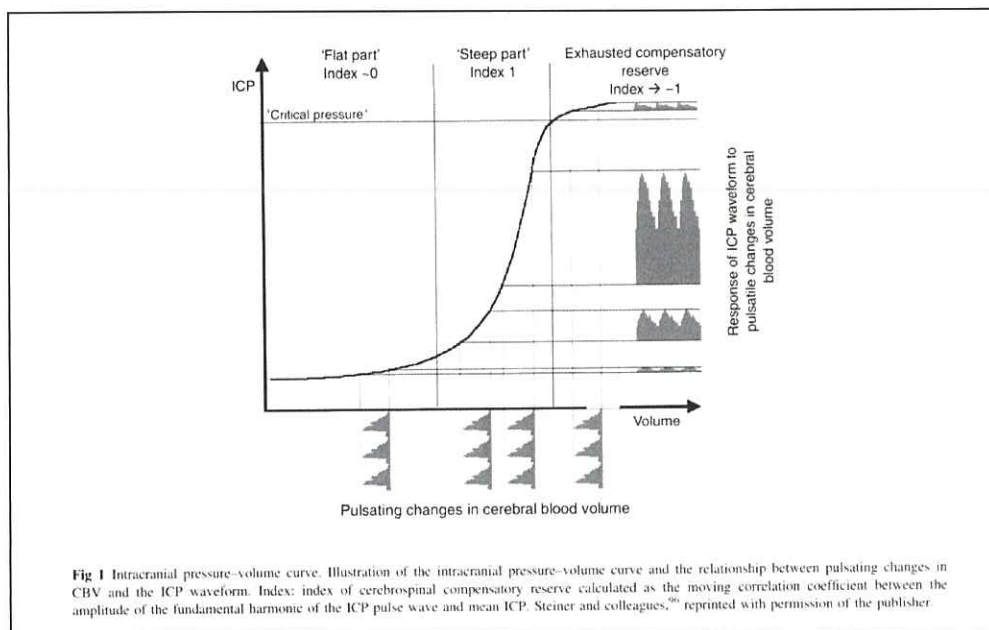

Lundberg A or plateau waves	Steep rise to >40 mmHg and persist for 5 to 20 min	Pathological. Intact auto regulation and reduced compliance. Decompensation and severe prognosis
Lundberg B	ICP oscillations at 0.5 to 3 waves per minute. ICP up to 20 mmHg above baseline	Pathological. Thought to be changes in vascular tone; synchronous ↑velocity MCA
Lundberg C	Oscillations at frequency of 4 - 8 per min	Little pathological significance. May be related to changes in arterial

Slight increase in ICP	Up to 20 mmHg
Moderate increase in ICP	20 to 30 mmHg
Severe increase in ICP	> 40 mmHg
CBF significantly reduced	50 mmHg

Measurement of cerebral blood flow

Techniques

Too numerous to cite here but include Kety-Schmidt principle, measurement of blood flow in arteries of the neck or cerebral venous outflow, artificial perfusion of the brain, heat clearance techniques, angiography, US, diffusible and non-diffusible tracer-based measurements of cerebral flow, laser Doppler, transcranial Doppler, near infrared spectroscopy, positron emission tomography (PET), MRI and functional MRI (fMRI or BOLD).

Kety-Schmidt

General principle

A modification of the Fick principle in which the blood flow of an organ can be estimated by finding the rate of removal of a given substance by the organ (uptake per minute) and dividing by the AV concentration difference across it. With K-S principle the marker is the highly diffusible but relatively inert N₂O. This is inhaled until the AV concentration difference is zero. At this point the brain tissue and venous tissue contents are in equilibrium and the brain tissue content per 100g is equal to the venous content per 100 ml times the blood/brain partition coefficient. The mean AV concentration difference during the uptake process is a result of this uptake and is simply the area between the AV concentration time curves. See similarity with thermodilution measurement of cardiac output. Thus:

$$\text{Organ blood flow} = \frac{\text{Uptake per time period}}{\text{Mean AV concentration difference}}$$

$$\text{Organ blood flow} = \frac{\text{Uptake}}{\text{Mean AV concentration difference} \times \text{time period}}$$

$$\text{Organ blood flow} = \frac{\text{Uptake}}{\text{Area between AV concentration - time curves}}$$

The brain content per 100g tissue is the same as the venous content per 100 ml x the partition coefficient (λ) . Thus:

$$\text{Organ blood flow (ml / 100g brain/min)} = \frac{C_v \cdot \lambda}{\int_0^u (A - V) dt}$$

(C_v is the cerebral venous content at end equilibrium and u is the time at equilibrium)

Kety-Schmidt principle: Arterio-venous N₂O levels during inhalation

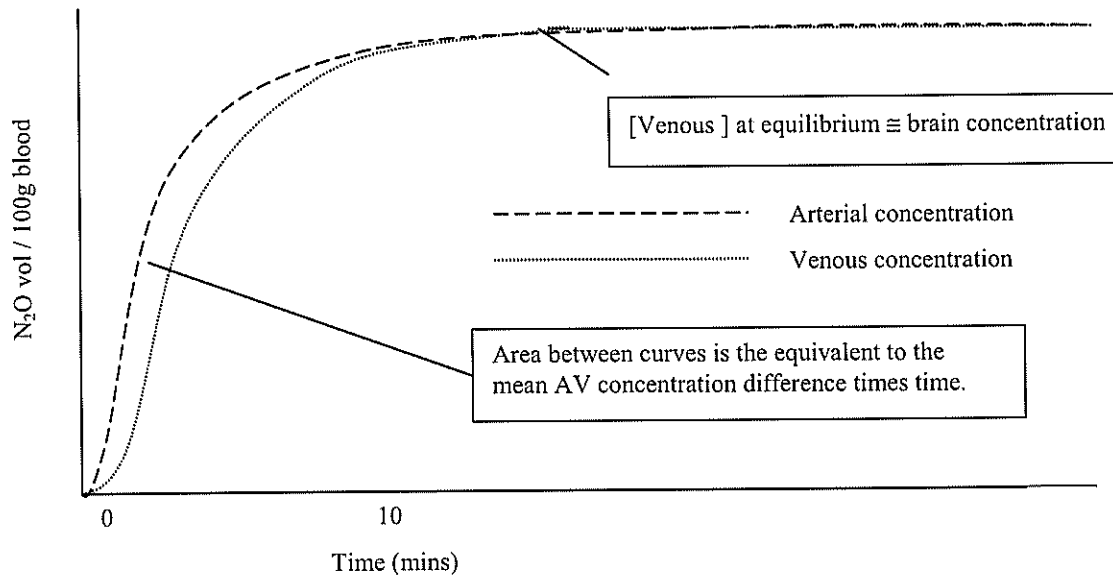

THE EXPONENTIAL PROCESS

Definition	A process where the rate of change of a quantity at any time is <i>proportional</i> to the quantity <i>at that time</i> . This applies to almost everything in the natural world and is an example of the ' <i>Universal rule of constant proportion.</i> ' <i>Exponential</i> refers to the exponent which is continually changing (usually with time).
Basic formula	$y = a^x$
What base can be used ?	Any number can be the base! However, the natural base 'e' is the most important and is often called <i>the</i> exponential base as if there are no others. Therefore, the usual formula is $y = e^x$
More detailed formula	$Q_t = Q_0 e^{kt}$ <div style="display: inline-block; vertical-align: top; margin-left: 20px;"> Q_t = quantity at time t Q_0 = quantity at time 0 t = number of time units k = basic growth or decay rate. </div>
What is e ?	e is 'the universal proportionality constant. It is a non-terminating, irrational number like π and when used as the base for exponential functions provides special mathematical properties.
What is the formula for e ?	$e = \lim_{n \rightarrow \infty} \left(1 + \frac{1}{n} \right)^n$ <p>Thus as n nears ∞, $e = 2.718\ 281\ 828\ 4\dots\dots\dots$</p>
What is special about an exponential process?	The rate of decline (s) is proportional to the amount present at the time (h). So s/h is a constant (k) called the Rate constant.
Units of the rate constant	hr ⁻¹ or sec ⁻¹
What is a time constant?	If the rate of decline was allowed to continue to 0 from any given point, the time taken for the decline is the time constant, tau (t).
What actually happens in one time constant?	The amount declines to 36.8 % of the starting value
What is significant about this number?	36.8 % is $1/e$
Thus what special property does the base e give?	It is a universal constant that enables us to calculate the outcome of any process whose rate is proportional to its own magnitude
	$Q_t = Q_0 e^{kt}$ <div style="display: inline-block; vertical-align: top; margin-left: 20px;"> Q_t = quantity at time t Q_0 = quantity at time 0 t = number of time units k = basic growth or decay rate. </div>
Examples of a negative exponential process	Washout of N ₂ from lung Thermodilution curve Elimination of drugs from a compartment Lambert / Beer's Laws of light transmission. $I_t = I_0 e^{-Ecd}$ Rate of decay of radioactive substance $m = m_0 e^{-at}$ Change in thermistor resistance with temperature

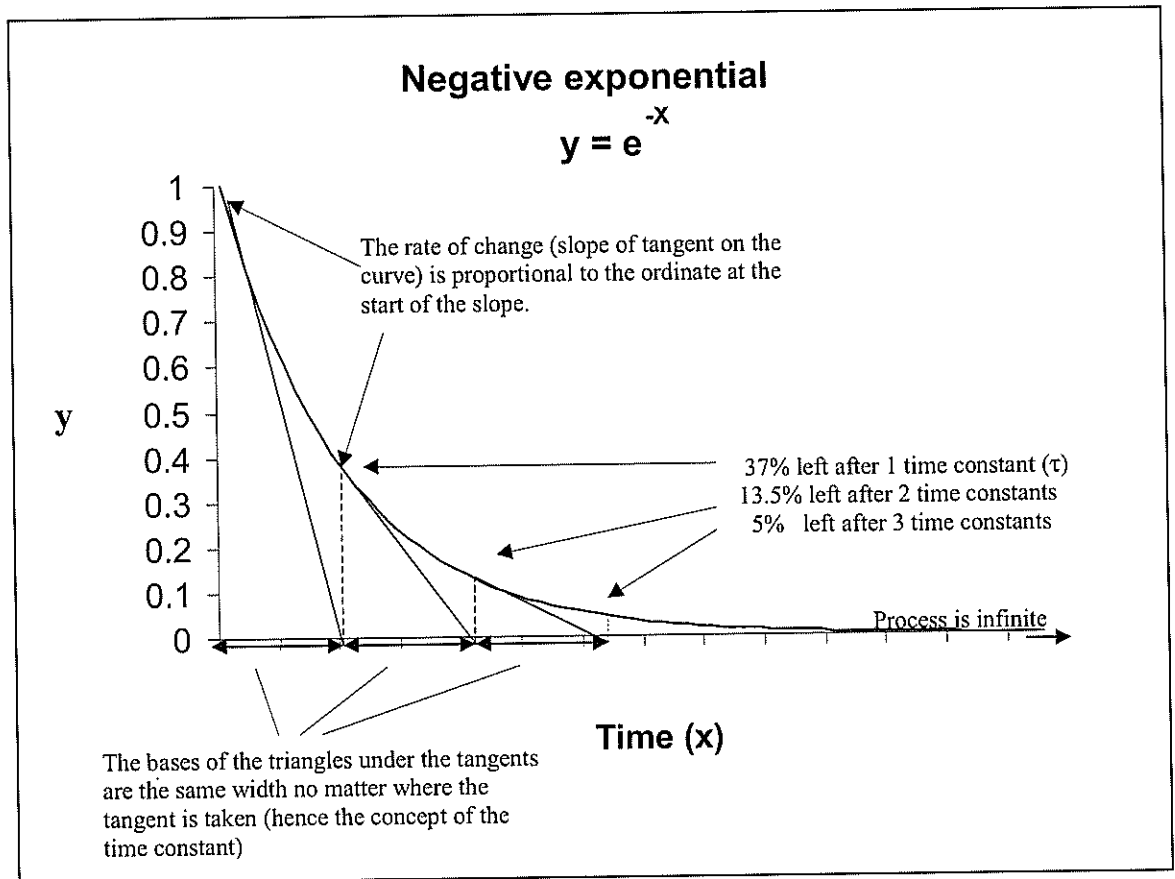

Examples of a positive (tear-away) exponential:

- Bacterial multiplication
- Cancer cell multiplication

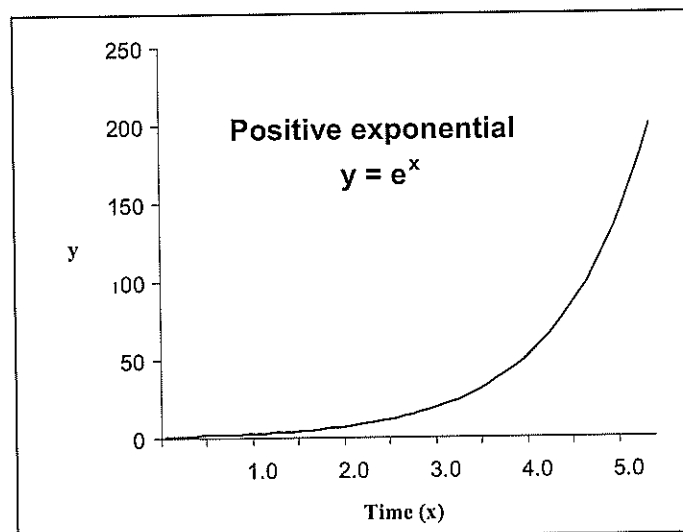

Examples of build-up curves:

Flows with a pressure generator ventilator

Wash-in curve of lung O₂

Anaesthetic uptake

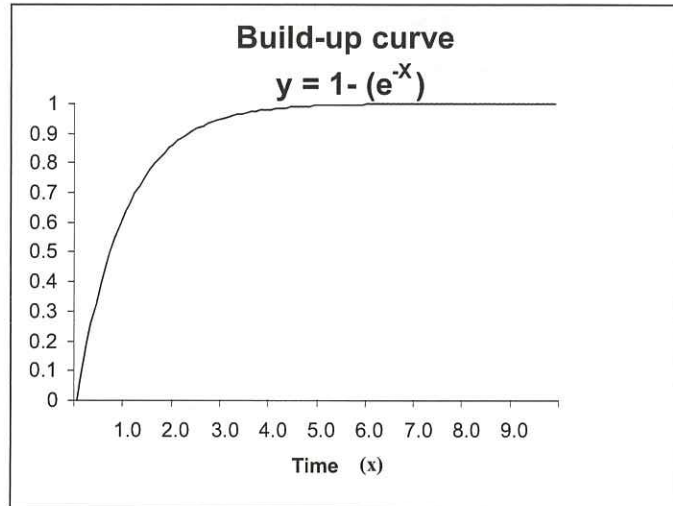

Summary of key points about the exponential process

In an exponential process, the rate of change of a quantity at any time is proportional to the quantity at that time. The process is infinite.

The duration of the process is measured in time constants and half lives

The time constant is the time at which the original process would be completed had the initial rate of change continued

In one time constant the amount present declines to $1/e$ or $\sim 36.8\%$

When base e is used, the calculation of the outcome of the process is simplified

The half life is the time taken to fall to half the initial value.

One half life is approximately 0.7 times the time constant

Although the plot of y against x is exponential, the plot of $\log y$ against x is linear

Other curves:

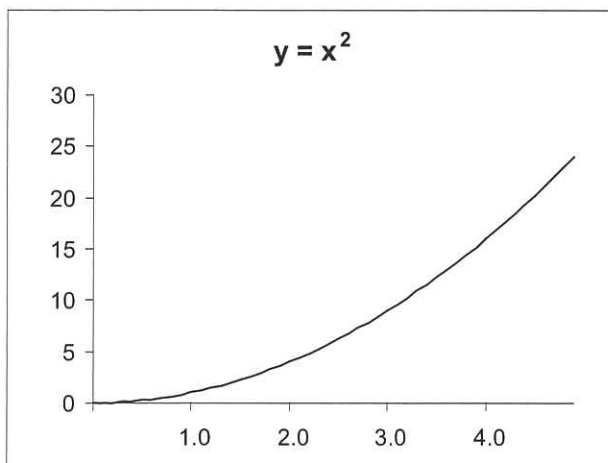

Examples:

Relationship between pressure and turbulent flow.

$$\Delta P = \text{Flow}^2$$

Example of rectangular hyperbola:

Boyle's Law: ($PV = k$)

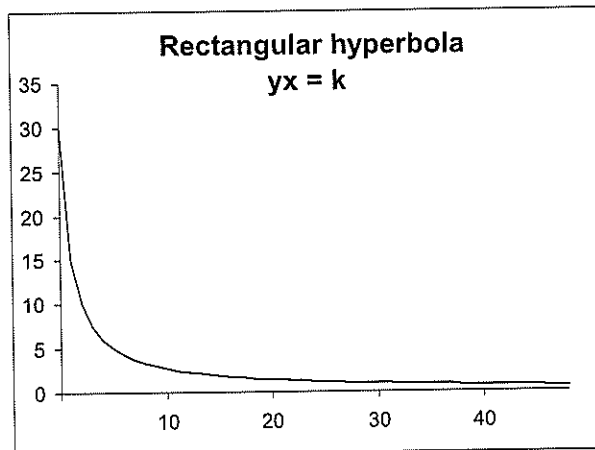

ELECTRICAL PRINCIPLES

General principles and definitions

Electricity	A general term for a variety of phenomena resulting from the presence and flow of charged particles (electrons or ions). This includes many well-known physical phenomena such as lightning, electromagnetic fields and electric currents.
Electric field	Any object with charge has an electric field around it – the region where it can attract or repel other charges. If a charged object is placed in the field it will experience a force.
Direction of forces	Opposite charges – attractive force Like charges – repulsive

Additional information about Electric fields

What determines the strength of the force? -The product of the two charges
-The permittivity of the space between them (k)
-Inversely to the square of the distance apart. (This is the 'inverse square law' and is analogous to that of gravity)

$$F = \frac{Q_1 Q_2 k}{r^2}$$

Electrical potential energy E_{electric} . The energy that would be required to move a charge from an infinite distance outside an electric field to a distance r away from a point of charge Q . For repulsive charges, this will increase as the charge is brought closer. Other factors determining the potential energy are the product of the two charges and the permittivity of the space between them.

Electrical potential The energy of an electrically charged particle in an electric field.

Charge and current

Static electricity	Earliest observation on effects of electricity. Materials become charged when electrons are transferred from one substance to another. One substance then has an excess electrons and the other has a deficit.
Unit of charge	Coulomb (can be pictured as a packet of electrons) One coulomb = 6.24×10^{18} electrons
Electric current	Rate of flow of charge Current (I) = Charge (Q) / Time (t)
Units of current	Ampere (A) One ampere is a flow of 1 coulomb per second

Charge and current	One coulomb (C) is charge deposited when one ampere flows for one second.
What does current depend on?	-Number of charge carriers (free electrons in metal; ions in a liquid). High numbers in metals, fewer in semi-conductors and negligible in insulators. -Charge (C) per charge carrier -Drift velocity – <i>Average</i> velocity of the charge carriers. The drift velocity is much, much less than electron speed which is 10^{-6} ms^{-1} . -Cross sectional area of the conductor
How is existence of electric current revealed?	Light Heat Magnetism
Direction of flow	Convention is that flow is positive in the direction of positive moving charge. In most cases, however, current is caused by the flow of negative charges and positive charges are stationary. Actual current flow is thus usually from -ve terminal to positive terminal.
Direct current	Flow of electrons along a conductor is in one direction only. (In reality electrons move a bit more haphazardly than this but the average drift is in one direction only)
Alternating current	Flow continuously reversing to produce, usually, a sine wave. AC may flow in one direction more than another and can be illustrated as AC added to DC.
Heat production AC vs DC	AC current with a momentary peak voltage of 240 V confers less power than DC current of 240 V. The power equivalent of a given AC current is found by squaring the sine wave potential, meaning it and taking the square root of the mean. This is called the root mean square. Thus, 240 V AC household current is really 240 V rms and, in fact, has a peak voltage of 340 V.
Advantage of AC	Flexibility and ease of transmission. For ease of transmission of power, very high voltages are used. These are then stepped down for the consumer using transformers.

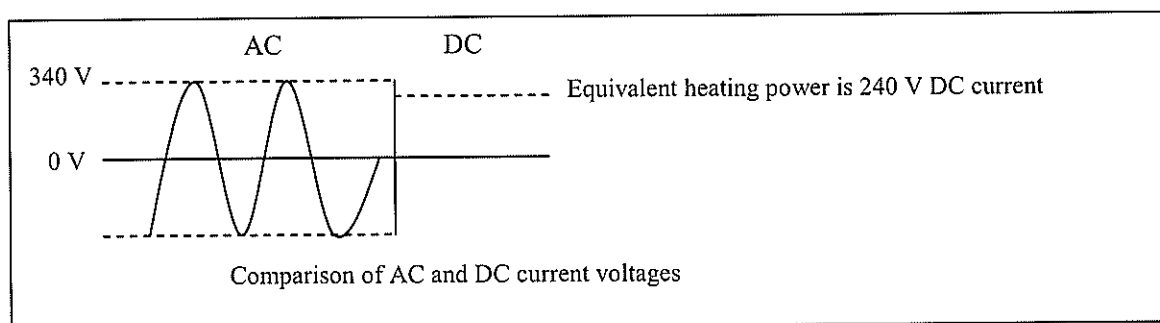

Principle of a fuse	Heat production \uparrow with \uparrow current flow. Fuse wire designed to melt when current increases to certain level.
Current density	Current density is current flow per unit area. Greater current density the greater the heating effect.

Voltage

Define

Difference in electric potential energy per coulomb transported between two points

1 volt = 1 joule per coulomb

Two contexts:

Potential difference

The energy used / converted when moving charge

Electromotive force

Source of energy eg from a battery

Potential difference

Potential difference or voltage

The potential difference is the work you do to move a charge through a resistor. The potential difference across a component is 1 volt when 1 joule of energy is used up to move 1 coulomb of charge through the component. The energy is converted to heat.

How much current will flow?

Depends on resistance

$$I = V / R$$

A component has a resistance of 1 Ω if a potential difference of 1 V makes a current flow of 1A.

This proportionate relationship is only true for *Ohmic* conductors (mostly metals) at constant temperature

Electromotive force

Is EMF a force?

No. It is the amount of electrical energy a battery produces for each coulomb of charge. Units are *Volts*

What is a battery?

A battery houses a chemical reaction and transforms its energy into electrical energy. A surplus of electrons builds up at one terminal and a deficit at the other. This is termed a *potential difference*. The greater the p.d., the greater the energy that can be transferred to components in the circuit.

Why does a battery heat up?

Electron collisions within the battery. These result in *its internal resistance* (r). (As opposed to the *load resistance* of the external circuit)

Is the EMF the same as the potential difference? No. It could only be if internal resistance was zero.

Relationship between EMF and current

Current produced is proportional to the EMF and inversely to the internal and external resistances.

How much work can a 6 volt battery do?

6 joules of work for every coulomb passed between two terminals. eg 6 joules is dissipated across the resistor for every coulomb passed.

Resistance

What does resistance depend on?

-Length of wire

-1 / Cross sectional area

-Resistivity of material (including environmental factors such as temperature and light intensity). Resistance results from electrons colliding with atoms and losing energy

Difference between conductors and insulators	The electrons of conductors are loosely bound and can move through the substance (a lattice of positive ions) under the influence of electrical potential. However, when you heat a conductor, the electrons collide with atoms and lose energy – hence resistance increases. In insulators, there are negligible numbers of charge carriers.
Semiconductors	Semiconductors have far fewer charge carriers than metals but when heated more charge carriers are released. Hence their use in temperature measurement.
Temperature and resistance	Semiconductors (most) \uparrow temperature \rightarrow \downarrow resistance Wire resistor \uparrow temperature \rightarrow \uparrow resistance
Ohm's Law:	The current flowing through a conductor is proportional to the electromotive force causing that current.
Definition of the ohm	The ohm is that resistance which will allow one ampere of current to flow under the influence of one volt potential.
Relationship between resistance, current and EMF	Resistance (Ω) = EMF (V) / Current (A)
Resistors in series:	$R = R_1 + R_2$
Resistors in parallel:	$1/R = 1/R_1 + 1/R_2$
When do you use the term impedance (Z) rather than resistance ?	When the resistance through the circuit is dependant on frequency.
Effect of AC frequency on resistance/impedence	Wire resistor AC frequency no influence on resistance Capacitor \uparrow AC frequency \rightarrow \downarrow impedance Inductor \uparrow AC frequency \rightarrow \uparrow impedance
When is the term reactance used?	When referring to impedance of a capacitor or inductor. Units still ohms.
What is a Wheatstone bridge?	A method to measure changes in resistance. It is a null deflection system in that, when it is balanced, there is no flow through the galvanometer.
Calculation	R1 and R2 are known resistances. R3 is a variable resistor. R4 is the resistance we are looking for. R3 is adjusted until there is no current flowing between A and B. At this point the resistances are balanced in the two limbs and the equation $R_1 / R_2 = R_3 / R_4$ can be solved.

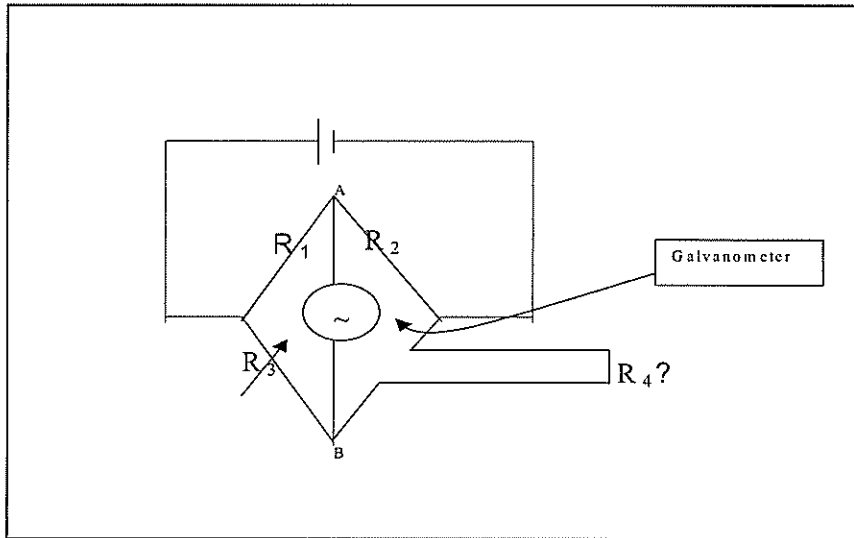

Power

Electric power

The rate at which electric energy is converted to or from another energy form, such as light, heat, or mechanical energy.

What is electrical power dependent on?

The power is related to the current flowing (number of coulombs per second) and the potential that the coulombs have at their point of application (joules per coulomb). The amount of work carried out by an appliance is, therefore, the product of current and potential difference across the appliance.

$$P = V.I \quad \text{or} \quad P = I^2.R$$

Equation for the total energy transferred.

Energy (kWh) = Power x time

Electromagnetic principles

What is magnetism?

When a conductor with a current flowing through it exerts a force on another conductor with a current. Iron has minute currents formed by motion of electrons orbiting nuclei.

Basic principles

Electromagnetism is one of the four fundamental forces by which particles interact with each other and is the force that acts between

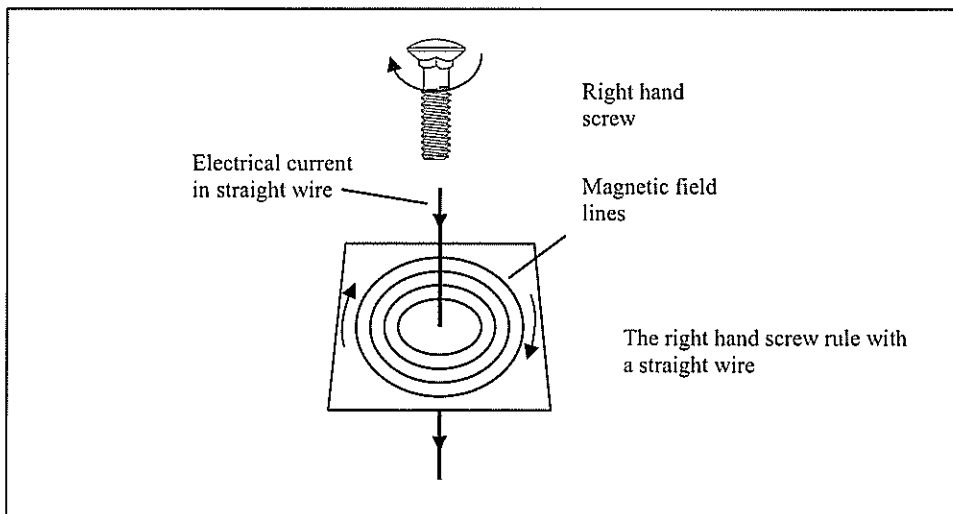

electrically charged particles. When a *current flows* in a wire a magnetic field is produced. The direction of the magnetic field lines are predicted by the right hand screw rule (see diagram)

What is an electromagnetic coil?

An *electromagnet* can be made by winding wire around an iron core. The strength of the magnet is increased if a) the number of turns of the coil increases b) the current is increased c) the poles are brought together.

Electrical motors

A magnetic field produced by current flowing through a wire can be approximated to a permanent magnetic field to cause a force. This is the principle behind electrical motors. The direction of the force is described by Flemings left hand rule. The galvanometer also works on this principle.

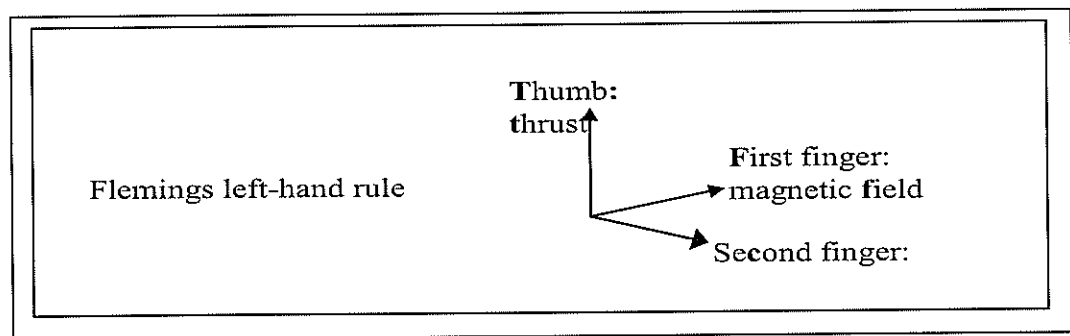

Electromagnetic induction

Electromagnetic induction is the production of electricity from magnetism. When a conducting rod is moved through a magnetic field its electrons will experience a force causing them to accumulate at one end of the conductor. This induces an electromotive force across the ends of the rod just as in a battery. If the rod is part of a circuit, a current will flow through it.

The same phenomenon will occur if a) the magnet is moved in such a way that its field lines are cut by a stationary conductor or b) the conductor is placed in a magnetic field that can vary in intensity with time (eg induced by an AC current).

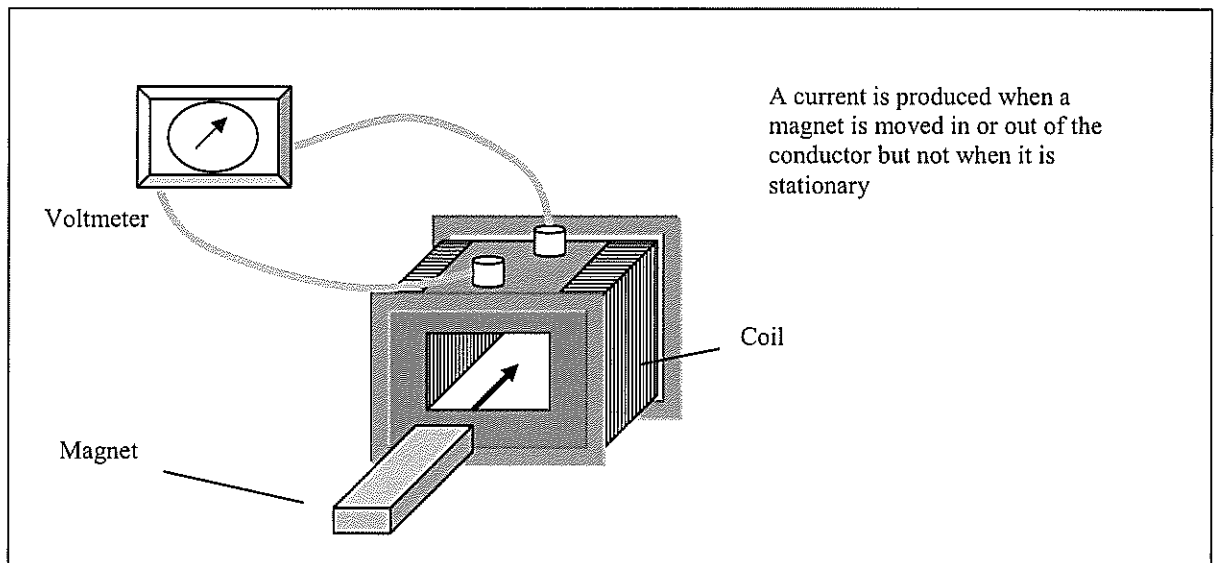

What determines the voltage produced?

- a) the rate at which the conductor cuts the magnetic field lines (Faraday's Law)
- b) the number of turns of the coil
- c) the strength of the magnet

Lenz's Law

The current produced in the coil produces a magnetic field whose polarity opposes the magnet's movement.

Transformers

A time varying magnetic field caused by an AC current can induce an EMF and AC current in another coil (*the secondary coil*) placed within the magnetic field (*mutual inductance*). To step up the EMF the secondary circuit has more windings and, to step down, the secondary circuit has fewer windings

Self inductance

An AC current passing through a coiled conductor also exhibits *self inductance* which opposes current flow in that conductor. It occurs because one turn of the conductor sits in the magnetic field of the next turn. AC changing magnetic fields induce opposing currents in opposite turns – thus dissipating energy. This is frequency dependant and the overall dissipation is termed reactance.

Examples of inductance:

1) In-circuit inductors

To prevent short-circuiting and to control current flow.

2) Electromagnetic flowmeter.

A conductor (eg blood) is moved through a magnetic field resulting in an electrical potential which is perpendicular to both the flow and the field. The magnitude of the current is proportional to the rate at which the conductor is moved.

3) Transformers

-Allow AC currents to be stepped up and down in the National grid. Power is transmitted at very high voltages to minimise current. (Power losses due to resistance are minimised at low currents)
 -Transformers are used to produce isolated power supplies in some theatre complexes (see Electrical Safety)
 -Transformers enable signals to be passed from patient to ECG machine without a direct connection ∴ patient is isolated from ECG machine.

4) Induced electrical interference

Coiled wires within equipment may induce magnetic fields and electrical interference in ECG and other monitors. Leakage currents on casings may also be induced this way.

5) AC generation

A rectangular coil is rotated in a magnetic field. Flux linkage maximum when plane of coil at right angles to flux, minimum when they are in same plane and maximum (but reverse direction) after 180° rotation → sinusoidally varying EMF.

Capacitance

Capacitor

Stores charge and consists of two plates separated by an insulator (dielectric). When a capacitor is charged by eg a battery, a surplus of electrons develops at one electrode and a deficit at the other. The electrons at one plate repel the electrons at the other causing a current to momentarily flow but then cease. A capacitor thus blocks DC current. If the two plates are then connected together a current flows from one to the other as the capacitor is discharged.

Capacitance

Relates electrical potential to the amount of charge that can be held..

Capacitance of a capacitor

Number of coulombs of stored charge per volt of potential across the capacitor.

$$\text{Capacitance (F)} = \text{Charge (C)} / \text{Potential difference (V)}$$

Units of capacitance

Farad : one coulomb of electricity will charge a 1 Farad capacitor to a potential of 1 volt.

Voltage

The higher the voltage across the plates, the harder it is to load the charge on.

Permittivity

Putting an insulator between the plates increases the permittivity by decreasing the force required to move the charge on to the plates. This decreases the potential difference across the plates and increases the capacitance.

Capacitors and AC current

While current still does not pass through a capacitor in an AC current circuit, because there is continual reversal of current flow, the capacitor continuously charges and discharges. This causes electrons to flow along the wires joining the plates and effectively results in an AC current flow. The greater the AC *frequency* the greater the current flow to and from the plates and the lower the resistance (reactance).

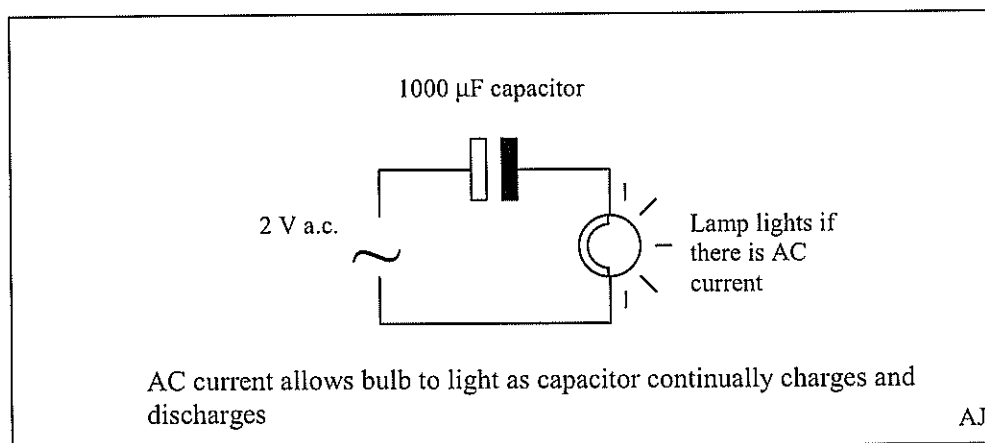

Factors which ↑ capacitance

↑ size of capacitor plates
↓ distance between plates
insulating material between plates

Some applications of capacitance:

1) To produce a radiofrequency current

If a capacitor and an inductor are placed in series, a current frequency can be chosen so that reactance of one cancels out the reactance of the other. A resonant circuit is thus formed in which the capacitor and inductor perpetually swap charge. This can produce self-perpetuating radiofrequency current as used in cell phones, diathermy etc.

2) Frequency band filter

Passive- Circuit as above with capacitor and inductor in series will allow current to flow if it is at the same, selected resonant frequency. All other frequencies will tend to be impeded.

Selective band reject- If the capacitor and inductor are placed in parallel, no current will flow at the resonant frequency. This means that specific selected frequencies can be filtered out. eg in an ECG machine

3) Isolating capacitor

In circuit between diathermy plate and earthed electrical apparatus. This allows the high frequency diathermy current to flow to earth but doesn't allow DC current to flow. Thus, if the patient is accidentally touched with low frequency mains current they are protected from electrocution.

Low impedance to high frequency current from diathermy also reduces risk of burning at diathermy plate.

4) Capacitance and interference

Although a capacitor does not allow the passage of electrons in direct current, AC current can produce alternating charge across the plates. The two plates could be an ECG electrode and an overhead light. 50 Hz current flowing in the light circuit may then lead to 50 Hz interference in the ECG.

5) Defibrillator

Charge is stored in a capacitor and released in a controlled discharge.

Galvanometers, ammeters and voltmeters

Galvanometer

A coil of wire is pivoted on a jewelled bearing between two poles of a magnet. As the current to be measured flows through the coil a magnetic field is produced which interacts with that of the permanent magnet. This causes the coil to rotate on its pivot and move a pointer.

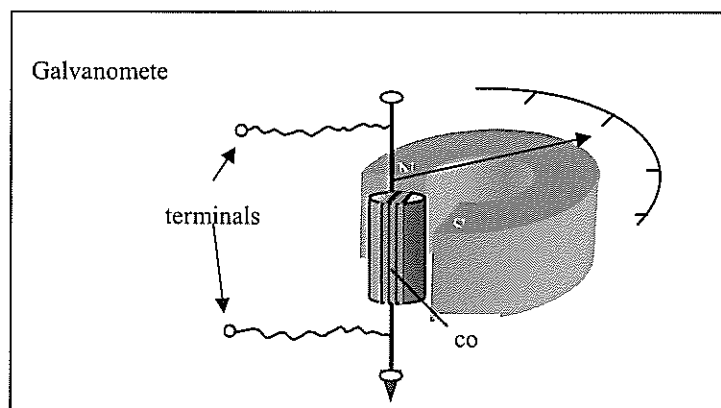

What is an ammeter?

A galvanometer with a known low resistance shunt in parallel with it to take most of the current. The ammeter is placed in series in the circuit.

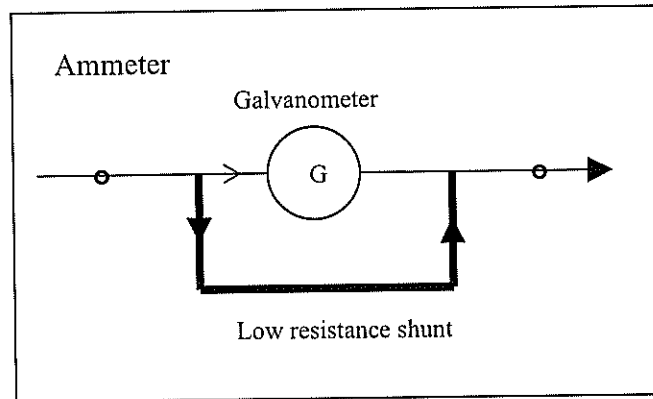

What is a voltmeter?

A galvanometer with a known high resistance is in series with it. The voltmeter is placed in parallel with the circuit. The high resistance means that the circuit current is not drawn off through the voltmeter.

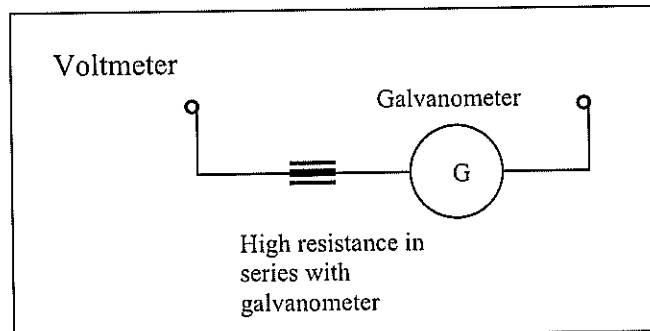

THE DEFIBRILLATOR

Aim	Drive a current of ~ 30 A across the heart. (Older defibs. ~ 50 A)
Requirements	<ol style="list-style-type: none"> 1. Lots of electrons. This is the charge on the capacitor and is usually about 100-150 mC. 2. Electrical potential across the capacitor that is going to drive the electrons through the thorax. ($\sim 2.5 - 5.0$ kV)
What is the energy of discharge?	The energy released by the capacitor is determined by the product of its charge and voltage and determines the current produced in the thorax.
How does this cardiovert?	The discharged energy produces a current across the heart \rightarrow synchronous contraction \rightarrow refractoriness \rightarrow restart of normal sinus activity
Confused by use of terms 'energy' and 'current'?	Use the term energy when talking about the energy stored and released from the capacitor. This is a predictable amount. Ultimately, however, it is the resulting current across the heart that is important for successful defibrillation but this is less predictable because the thoracic impedance is generally unknown. Because of this we defibrillate according to the energy of the capacitor rather than what is really important, the current.

Defibrillator circuit.

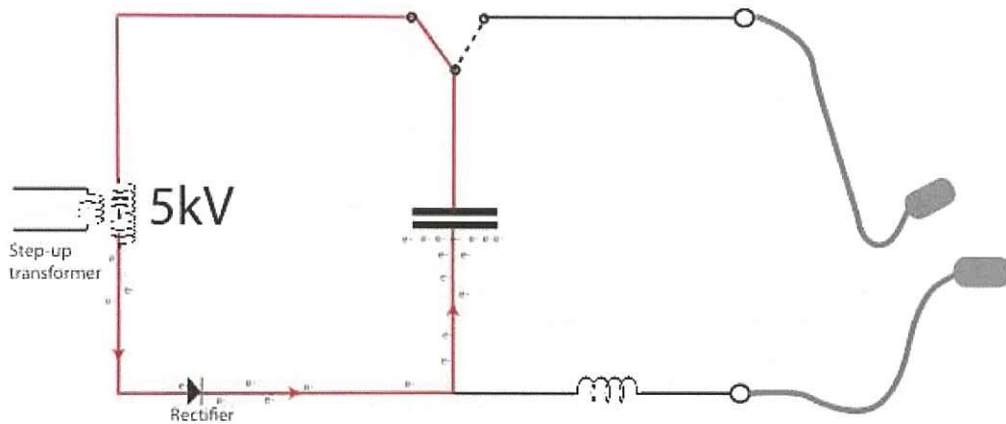

- The mains voltage is stepped up to ~ 5000 V.
- The rectifier changes AC to DC current.
- The inductor in the circuit will prolong discharge a little
- With the switch in this position the electrons are forced onto the capacitor plate

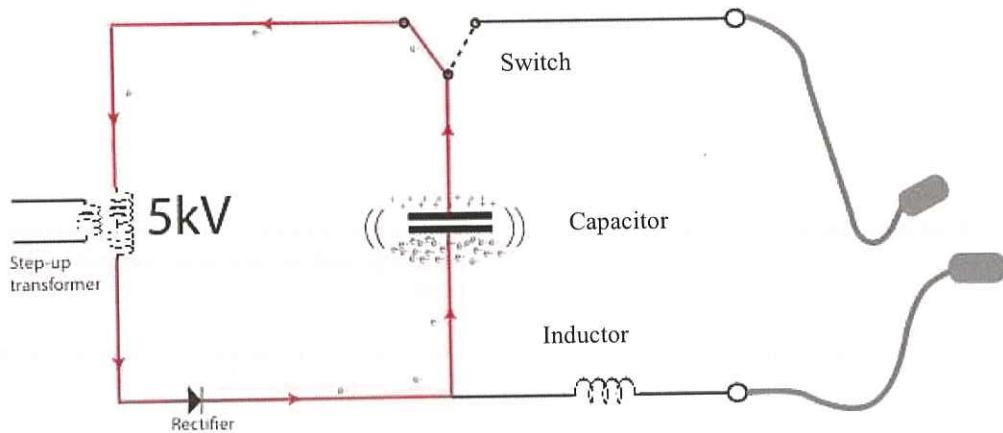

- The electrons building up on the plate cause an increasing negative charge which will gradually inhibit further build up.
- The charging will grind to a halt when the electrical potential on the plate is equal to that from the source ~ 5000 V.

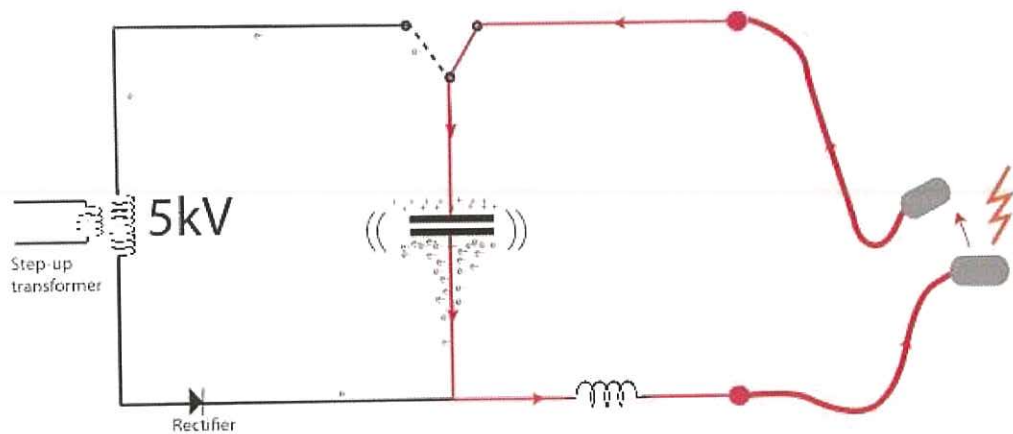

- When the switch is changed to discharge, the electrons are repelled off the plate by the electric force-field (electrical potential) of the capacitor.
- As the electrons move off the plate the electrical potential driving them also consequently falls. The total energy released by the capacitor is therefore half (approximately) what we might expect if the force-field was maintained. Example below (remember 1 volt = 1 joule/coulomb)
 Energy released by capacitor (Joules) = $\frac{1}{2} \times \text{Charge (C)} \times \text{Voltage (J/C)}$
 Energy released by capacitor: $250 \text{ J} = \frac{1}{2} \times 0.1 \text{ (C)} \times 5000 \text{ (J/C)}$

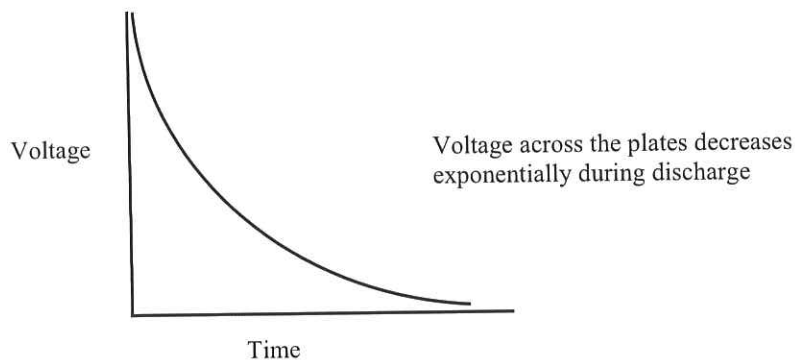

Monophasic v Biphasic defibrillators

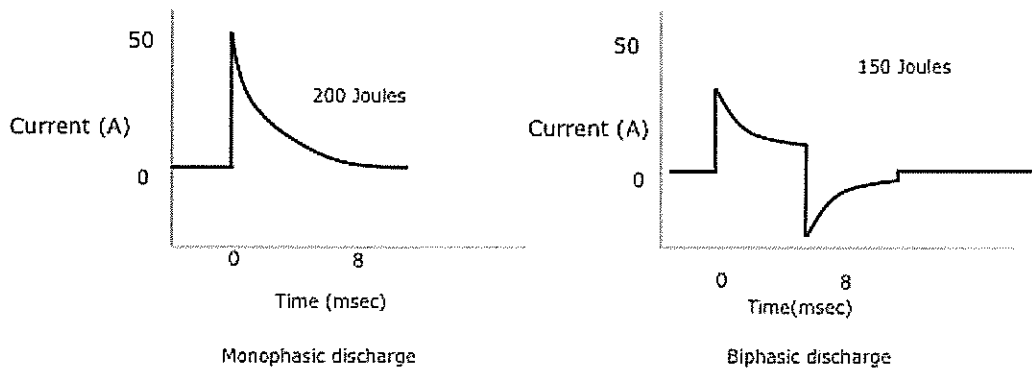

Monophasic defibrillators

- Discharge from one paddle to the other
- Impedance of thorax unknown therefore discharges 200-400 J energy in order to ensure an adequate current across heart.
- Peak current is therefore often excessively high with, potentially, myocardial damage.

Biphasic defibrillators

- Discharge from one paddle and then from the other
- Biphasic discharge lowers the threshold for successful defibrillation (reasons not entirely clear)
 - Better efficacy with lower current and energy
 - Less myocardial injury (related to peak current)
- Some BDF's able to sense electrical impedance of patient and will prolong discharge if high impedance. (The efficacy of defibrillator increases with prolongation of discharge up to about 12 msec.)
- By sensing thoracic impedance, some modern BDF's are able to deliver a constant current rather than exponentially changing currents.

Recommendations (Australian resuscitation council)

Adult
Children

Biphasic energy levels of 150 J
Biphasic energy levels of 1 – 2 J / kg

ELECTRICAL SAFETY

Macroshock

Electrocution	Faulty apparatus leads to equipment being live. If a person who is earthed touches the equipment, they will complete a circuit through earth and back to the PowerStation (via neutral part of circuit which is connected to earth)
Risk to patient	<ul style="list-style-type: none"> • Burns (Rate of heat production : Power (P) = I² x R) • Nerve and muscle stimulation (including myocardial depolarisation, injury and ventricular fibrillation) • Ignition
Determinant of injury	Remember that it is the current running through the body that determines injury. The electrons in the current accelerate tissue electrons, and pass on their energy to heat tissue.

<i>Determinants of injury</i>	
Magnitude of current at vulnerable site	High voltage – increases current Low resistance – wet skin increases current NB: High voltage breaks down skin → ↓ resistance
Type of current	Both AC and DC are dangerous!
Frequency	Low frequency ~50 Hz worst. High frequency less dangerous as penetrates tissue poorly
Duration current	Prolonged electrocution worst
Pathway through body	Different injuries from different paths
Timing	R on T

Skin resistance 10,000 ohms, Voltage power lines 240 rms., current 17 – 34 mA. Should be able to let go but as epidermis breaks down, resistance decreases and current rises to 340 mA.

<i>Current flowing through chest Injury</i>	
0.1 to 1 mA	Tingling sensation
5 mA	Pain
15 mA	Muscular contraction
50 mA	Respiratory arrest
30-100 mA	VF
6 A	Sustained ventricular contraction
30 – 50 A	Defibrillation

Source of 'macroshock' current	Leakage currents on enclosure. May be large or small. Sources include direct contact with live wire after damage, wet insulation, capacitive coupling.
--------------------------------	--

Protection against macroshock – summary.

1. Patient issues – earth free
2. Equipment issues
 - a. Earthing of casing
 - b. Fuses
 - c. Ground fault circuit interrupter (or RCDs or ELCBs)

- d. Isolated circuits
 - i. Isolating transformer
 - ii. LIM
 - e. Standards and design of equipment
 - i. I,II,III,B and C sub-classifications
 - ii. Regular maintenance
3. Prevent static build up (not so much a macroshock issue but worth mentioning)
- a. Theatre humidity > 50%
 - b. Antistatic footwear, floors, trolley, reservoir
 - c. Earthed casing

Patient issues

Patient must be earth free

1. Patient positioned so that they are not touching earthed equipment
2. Should never lie in wet pools / drapes
3. Equipment connected to patient must not provide a route to earth eg ECG leads, diathermy
4. Staff should wear insulating footwear (75 k Ω - 10 M Ω)

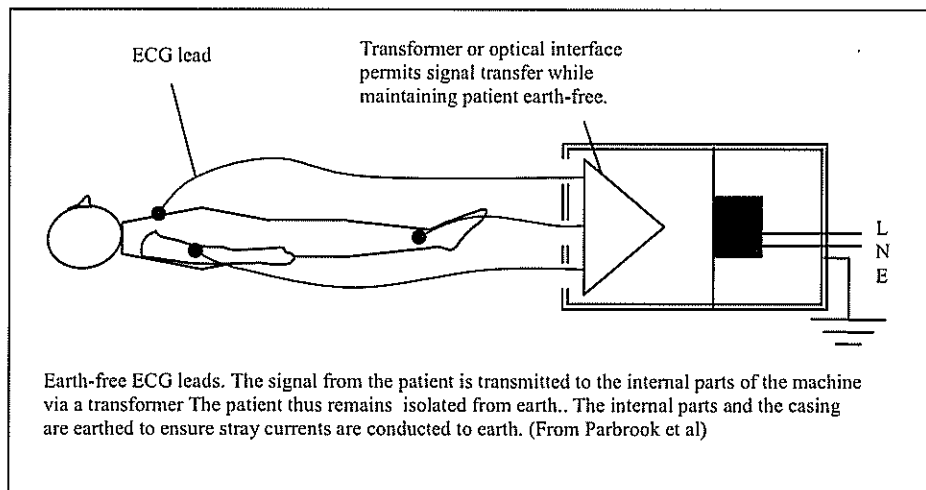

Equipment issues

1. Earthing

Why 'earth casings'?

- Provides low resistance route to earth for large or small stray currents.
- If a live wire touches an earthed casing, a large current will surge down this path of least resistance to earth - blowing the fuse or tripping the RCD. If earth was faulty, a person could touch the casing and the current would flow through *them* to earth - electrocuting them. Seen in conjunction with fuses on all Class I equipment.

Earth plugs and points

- Connects casing to earth via third wire in plug or via separate cable.
- *Equipotential earth* points in theatre ensure all metalwork is at same earth potential so that if connection occurs between two casings, current won't flow between them.

-Earth prong on three point plug is longer than other two, to ensure earthing occurs before power connected.
-Earthing can be broken if faults or improper extensions used.
Note: Patient themselves must not be connected to earth. Circuits and equipment connected to the patient must be earth-free

2. Fuses

Why? Placed in live wire part of circuit. If current surges due to re-routing down a path of low resistance, the high current causes the fuse to melt and the circuit is broken.
Fuses are placed at the entry of power to a building and in Class I apparatus.
Note: Cuts power off which may compromise patient safety

Limitations as sole protection No warning of current leakage through earth unless LIM.
Circuit disconnection (because of fuses or RCD) may compromise patient safety

3. Ground fault circuit interrupters (GFCI)

Other names Residual current device (RCD) or Earth leakage circuit breaker (ELCB)

Ground fault circuit interrupter Under normal conditions the currents in the active and neutral conductors of a circuit are balanced. In 'macroshock' some current is diverted to earth through the victim and this causes an imbalance between active and neutral conductors. The very sensitive sensing coils detect this imbalance and disconnect the power supply very quickly.

Problem Power is interrupted, which could compromise safety of patients dependent on electrically powered machines eg bypass machine

4. Isolating transformer

Application Portable electrical equipment (Usually Class II)
Power supply to some theatres (mainly cardiac theatres)

In normal power supplies the neutral is connected to earth. If you are connected to earth and touch the live wire a current can go through you to earth and back to the source via the earthed neutral. You form part of the circuit.
In an isolated power supply, the mains power supply (primary circuit) passes through a transformer by electrical induction. The circuit on the patient side of the transformer (secondary circuit) is not connected to earth at all. Thus an earthed patient or staff member touching one limb of the secondary circuit does not form part of a circuit and will not be electrocuted. Safety is only ensured if the secondary circuit has no earth connection at all. You do not want to touch both poles of the secondary coil, however! There will be a high voltage across you and you will be electrocuted.

5. Line isolation monitors (LIM)

Application

Used in conjunction with isolated power supply to monitor the integrity of the isolation of the secondary circuit from earth. Essentially a milliammeter. If a fault occurs which grounds the secondary coil, a leakage of current will occur through the LIM and an alarm will sound at ~ 5 mA. The circuit is *not* disconnected by the LIM.

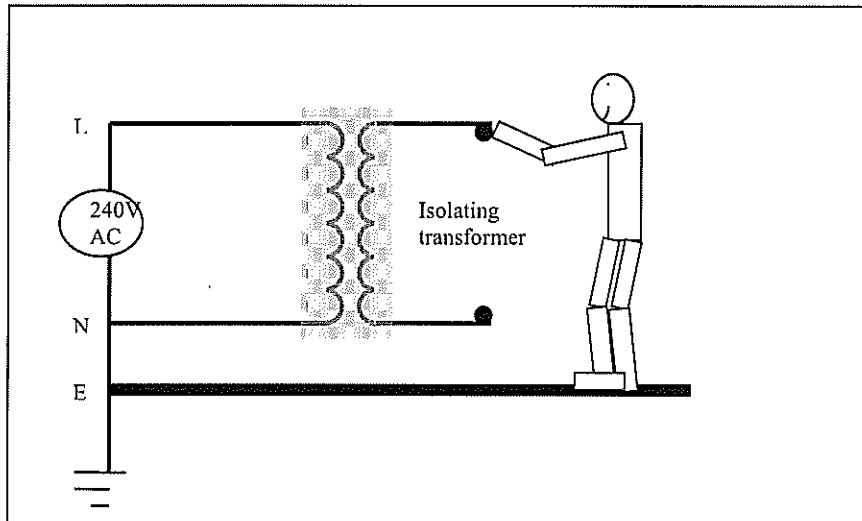

Schematic diagram of an isolating transformer power supply

6. Maintenance and design of equipment

Regular inspection and maintenance of equipment is essential

Classification of medical electrical equipment	
Class I	Basic protection in metal casing equipment. Wires insulated from each other and from user, casing earthed, fuses within equipment and (in UK) in live terminal plug. If casing becomes live, the current in the circuit is so high that the fuse melts, cutting off the power.
Class II	All accessible parts protected by double insulation. May have isolating transformer. Casing must not be earthed.
Class III	No potentials exceeding 24 V AC or 50 V DC. Internal power supply or connected to mains via adapter.
Class B	I, II or III equipment: Adequate protection against electric shock with regards to leakage current and reliability. Suitable for external use only
Class BF	No connections between patient and earth. Floating input circuits
Class CF	I, II or III equipment. High protection against microshock as very low leakage currents. Considered safe to connect to heart. Class I currents $\leq 10 \mu\text{A}$; Class II currents $\leq 50 \mu\text{A}$

Microshock

Tiny currents but with significant current density which are deposited directly into myocardium can cause fibrillation.

Local current producing VF

100 - 150 μA

Factors leading to microshock

1) Potential - need only be small eg 1 volt between patient and equipment casing. May arise from inductance of leakage currents in metal casing. Normally these currents flow to earth.

2) Patient earthed by direct contact with earthed equipment or anaesthetist touching patient and earthed equipment.

3) Route into heart -CVP, Swan, Oesoph. temp probe, pacing wire

Prevention

Prevent build-up of leakage currents (see below)

Prevent earthing of patient (see above)

Don't touch metal casings and intracardiac catheter at same time

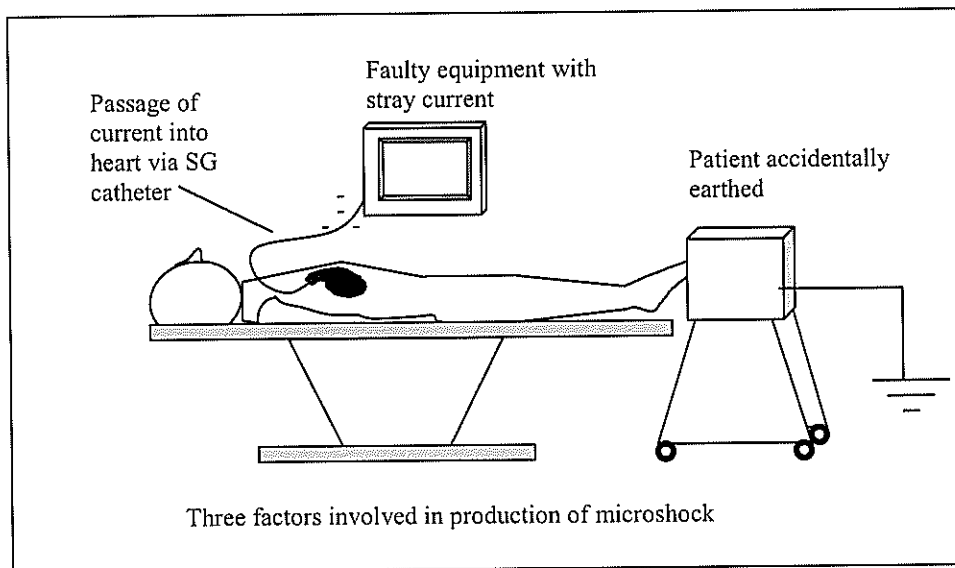

Electrical safety symbols

Subclassification of Class 1 equipment:

Type B equipment



Low leakage currents of up to 100 μ A (Class I) or up to 500 μ A (Class II). May be connected directly to patient but not safe for direct connection to heart



As above but has defibrillator protection. The significance of the paddle symbols is the same in BF and CF equipment

Type BF equipment



As for Type B equipment but all parts applied to patient are isolated from the rest of the equipment. *Floating circuit*

Type CF equipment



Equipment that is designed with very low leakage currents and is considered safe for direct connection to heart. Class I currents $\leq 10 \mu\text{A}$ and Class II currents $\leq 50 \mu\text{A}$

Class 2 equipment

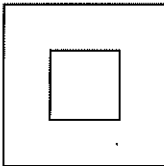

Equipotential earth



Ensures all metalwork is at the same (near zero) voltage. If this were not the case any accidental connection between the casing of two appliances (eg by touching them both) would cause a current to flow between them.

ELECTROSURGERY

What is it?	High frequency (10 kHz - 1 MHz) current passed through body between two electrodes. Can pass across heart safely as high frequency currents have low penetration and fail to excite contractile cells.
Electrocautery v Electrosurgery	Electrocautery uses direct current confined to a heated wire. Electrosurgery uses AC and the current moves through the patient's body. Discussion now limited to electrosurgery
Unipolar	The current arises from the electrosurgical generator and flows to the active cutting electrode. This has a small area and a <u>high current density</u> and causes burning. The current dissipates through the body to leave at the diathermy plate. This has a large area and consequently a low current density and doesn't burn. The current returns to the electrosurgical generator.
Bipolar	Current passes between blades of forceps. Earth free. Usually at lower voltage and less collateral tissue damage. Increased time for coagulation. More tissue adherence and tearing of adjacent blood vessels.
<u>Tissue effects</u> Power requirements	30 – 80 W
Cutting	Continuous (100% on) Lower voltage
Coagulation	Interrupted, damped current (eg 6% on 94% off) Higher voltage
Blend	Haemostasis needed while cutting (Different ratios of on and off)

Keeping the patient earth-free

How is patient kept earth free?	<ol style="list-style-type: none"> 1. The diathermy power supply may be isolated through a transformer 2. An isolating capacitor in the circuit inhibits low frequency mains current but allows high frequency diathermy current. (See diagram below)
---------------------------------	---

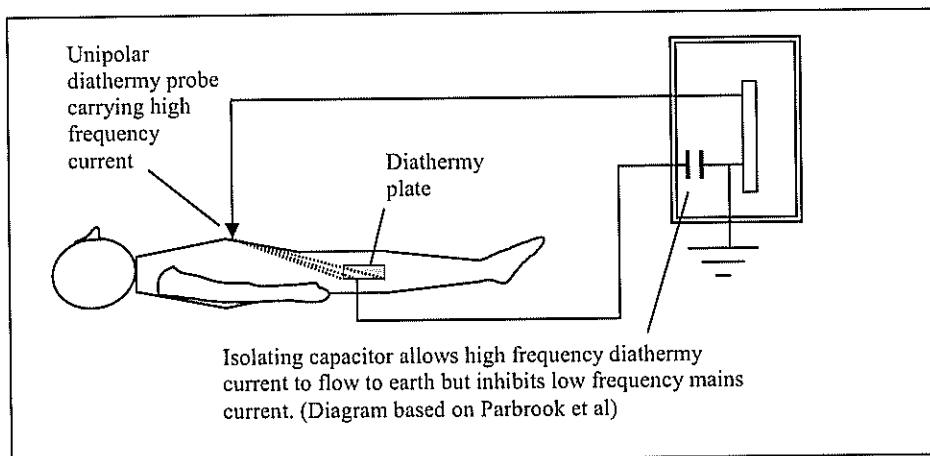

Why is the circuit earthed?	Allows stray diathermy currents to earth via the diathermy plate rather than via any accidental patient/table contact.
-----------------------------	--

Complications of electrosurgery and their prevention

Burns from accidental application	Care, sheath forceps when not in use
Burn at the plate	Use large plate; ensure good plate contact Contact quality monitoring systems- inactivate generator if fault at return plate
Direct coupling	The current flows from the active probe to an adjacent metal object (eg laparoscope) in close proximity. This acts as an extension to the active probe and can burn tissues (eg bowel) in contact with it. Prevent by always visualising the active probe and avoid contact with any other conductive instruments.
Insulation failure	A break in the insulation of the active electrode will cause burn in tissue in contact. Active electrode monitoring systems reduce risk by monitoring stray electrical currents.
Capacitive coupling	Current established in conducting tissues (eg bowel) not in contact with the active electrode. The bowel is acting as a capacitor plate. Also has occurred between patient and metal of operating table causing sacral burns.
<u>Prevention</u>	Metal trocars reduce this by drawing the current away to the return pad. Limiting time at high voltage Active electrode monitoring system
Electrocution	Patient comes in contact with live mains circuit should not be electrocuted if they are earth-free. See earlier.
Infarction of a pedicle	Avoid monopolar diathermy
Fires and explosions	Use non-flammable gases and antiseptics, avoid puddles, avoid carrier gases that support combustion
Pacemaker / ICD	Damage, inhibition, initiation of defibrillation Magnet to institute fixed pacing mode, bipolar diathermy, plate and forceps distant from pacemaker
ECG interference	

The Harmonic scalpel

Ultrasound instrument using 55.5 kHz waveform
No electrosurgical current generated.
Lower heat generation.

Secondary

Bronchoscopy to assess extent of thermal damage
Consider steroids and antibiotics
ICU

ASSESSMENT NEUROMUSCULAR BLOCKADE

Clinical assessment

Sustained head lift 5 secs
Generation vital capacity of at least 10 ml/kg
Inspiratory pressure at least -25 cmH₂O
Tidal volume not reliable – Normal VT can be achieved with only 20% functional diaphragm receptors

Peripheral nerve stimulators

Twitch frequency

TOF: 2 Hz
Tetanic: 50 – 100 Hz (usually 50 Hz)

Recommended current

Supramaximal (ensures recruitment of all muscle units)
Ulnar: 15 – 40 mA
Obese: 50 – 60 mA may be reqd.
NB: The bottom line in depolarizing nerve is the current. The battery voltage and the skin resistance determine the current.

Duration stimulus

0.2 – 0.3 ms

Stimulus 'shape'

Square wave (= Constant current during stim)

Sites of stimulation

Ulnar nerve (wrist) → Abd pollicis brevis
Common peroneal nv. → dorsiflexion foot
Posterior tibial nn. → plantar flx toes
Facial nerve → orbicularis oculi
Negative electrode: Closest to nerve
Positive: Proximal (distal from muscle)

Polarity of electrode and site

Assessing the response

1. Observation / Palpation
2. Mechanical force transducers

Problem is comparison with non-relaxed control
Remote, print out, objective,
Strain gauge measures tension generated in muscle. Requires pre-tensioning of abductor pollicis brevis. Splinting of hand reqd.
Acceleration proportional to force and inversely proportional to NMB.
Incorporates piezoelectric that transduces acceleration into electrical potentials
Can't assess tetanic contractions

3. Accelerometers

4. Integrated EMG

Ulnar → Adductor pollicis
Suggested to underestimate block with non-depolarising relaxants in twitch amplitude and ToF ratio
Diathermy interference, skin resistance changes

Stimulation Patterns

The following refer to non-depolarising blockade

1. Twitch

Pattern

Short duration square wave (0.1 – 0.2 ms)

Frequency: 1 Hz

Importance?

Little value unless you have a comparison with unblocked state

Twitch magnitude starts to ↓ when 75% receptors occupied

2. Train of Four

Pattern

Four twitches over 2 secs at 2 Hz

Leave 30 secs between ToF attempts

Assessment

Fade

ToF ratio T4 / T1

ToF count

Rules of thumb: ToF count

Reversal attempted: 3-4 twitches present

Upper abdominal sx or intubation: 1 or less present

No twitches: 100% receptor occupancy

T1 present only : 90% receptor occupancy

T1, T2 only: 80% receptor occupancy

T1 – T3 only: 75% receptor occupancy

ToF ratio

Residual effects of NMB disappear at 0.9. ToF ratio of 0.75 no longer thought to be adequate though it is not always *clinically* distinguishable from 1.0

3. Tetanic

Pattern

50 Hz (20 msec intervals) for 5 secs

Some devices work at 100 Hz (10 msec intervals)

Importance

Fade ⇒ suggests residual NDM block

4. Post-tetanic facilitation

Pattern

To assess profound NMB

5 secs 50 Hz tetanus → 10 secs twitches at 1 Hz

What is happening?

Post-tetanic potentiation of ToF due to mobilisation of pre-synaptic Ach. ↑ competition with NMB

Post tetanic twitch count:

Fade?

1 – 2 twitches only – profound NMB

9 twitches ≈ ToF count of 1

5. Double burst stimulation

Pattern

3 impulses of 50Hz Tetanus at 20 ms intervals every 750 ms

Importance

Magnitude of response 3 x greater than simple ToF

Ratio of first to second burst easier to interpret than ToF in light residual paralysis.

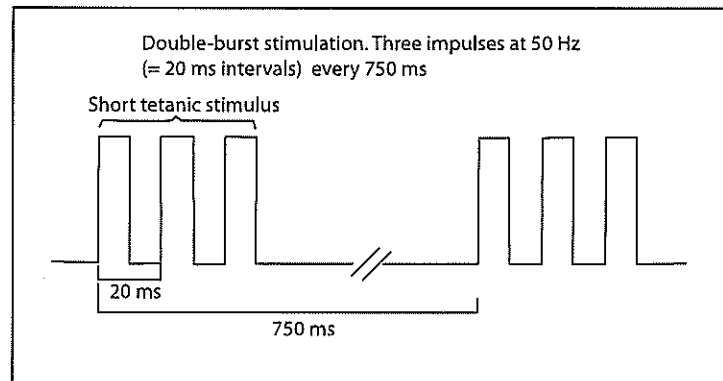

Depolarising block

Equal but reduced twitches

No fade

Reduced but sustained contraction with tetanic

No post tetanic potentiation

Problems and Safety aspects

1. May not reflect diaphragm effects

Diaphragm least sensitive to NMB. Smaller the muscle group the more sensitive to NMB

SCAVENGING

Example of maximum accepted concentrations
(Differs between countries)

25 ppm N₂O
2 ppm of any halogenated agent
0.5 ppm halogenated agent in presence of N₂O

Methods to decrease theatre pollution

Adequate theatre ventilation (eg air changed 15-20 times per hour)
Scavenging
TIVA
Circle
Regional anaesthesia

Scavenging

Collects waste gases and discards them safely
Should not affect breathing system, oxygenation or ventilation or patient

Classify scavenging

1. Passive

Exhaled gases driven by patient or ventilator
Passes out through 30 mm shroud on APL valve
Receiving system with valves that prevent excess negative or positive pressure
System vented passively to atmosphere

Problems

Less efficient
Reversal of flow possible
Excess negative pressure possible through wind and venturi effect
Incursion by insects

2. Active

Gases pass out of breathing circuit as above through 30 mm shroud on APL valve
Receiving system: valveless open-ended reservoir with bacterial filter
Active disposal:

Fan or pump generates a vacuum.

Flow rate (30 – 120 l/min)

Problems

Excessive negative pressure may collapse the reservoir bag
Obstruction beyond receiver may cause xs positive pressure